

PLAN DU TRINEAU DU PÈRE NOËL (PI-2002)

SANTA'S SLEIGH PLAN (PI-2002)

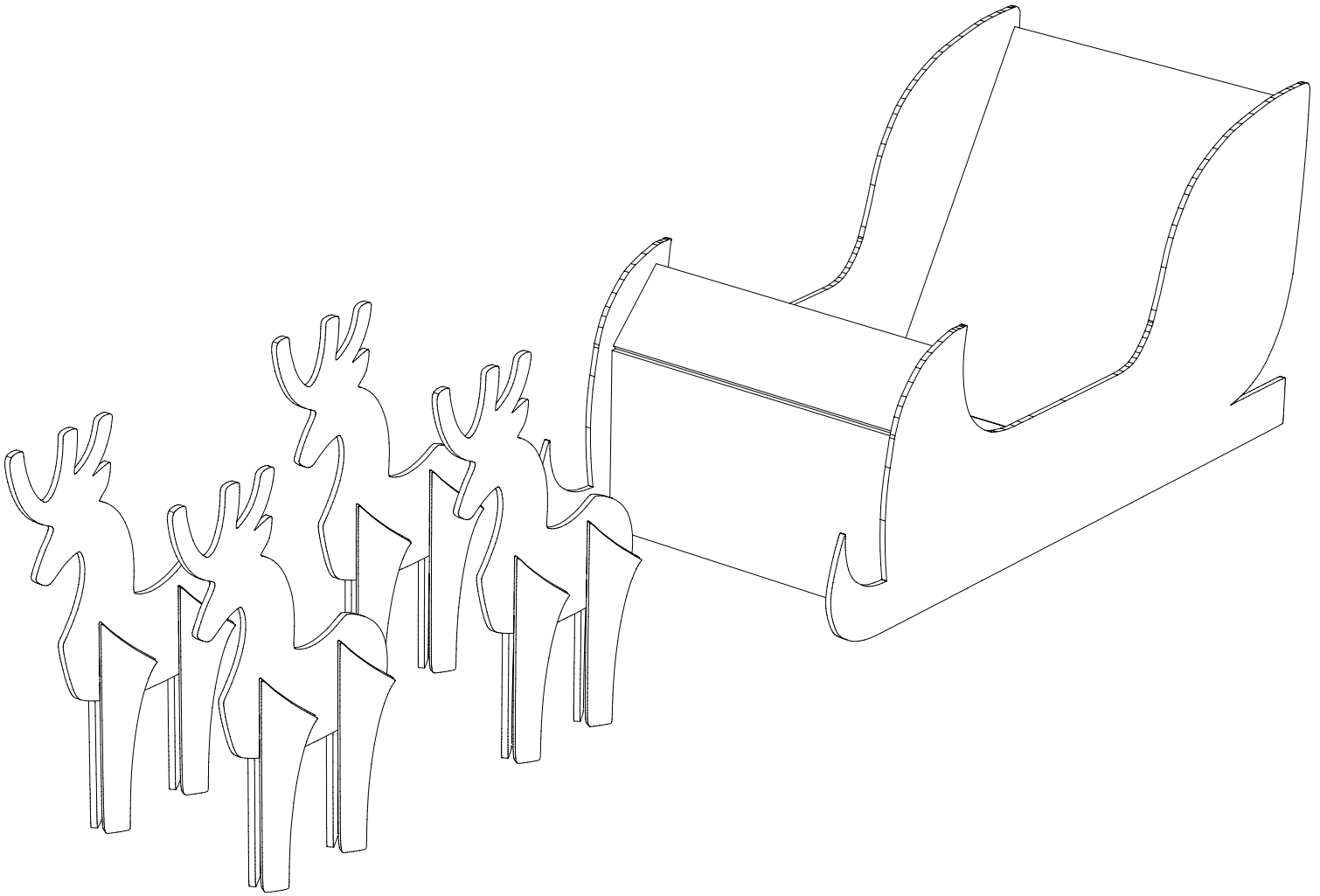

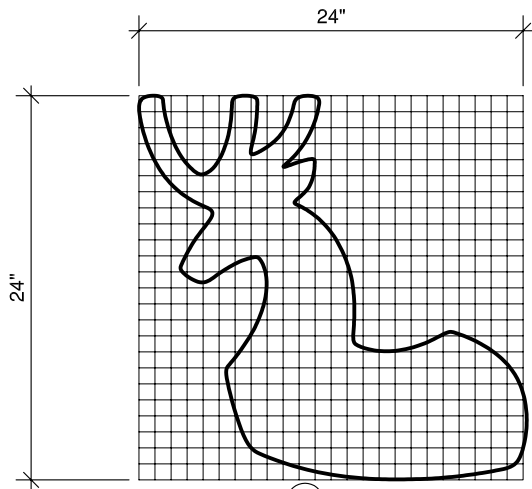



①
 CONTREPLAQUÉ 1/2"
 4 REQUIS
 1/2" PLYWOOD
 4 REQUIRED

1 □ = 1"

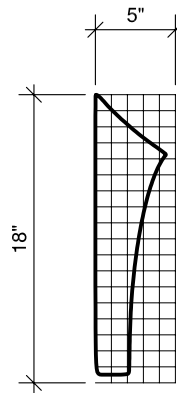

②
 CONTREPLAQUÉ 1/2"
 16 REQUIS
 1/2" PLYWOOD
 16 REQUIRED

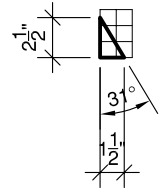

③
 2 x 2
 32 REQUIS
 2 x 2
 32 REQUIRED

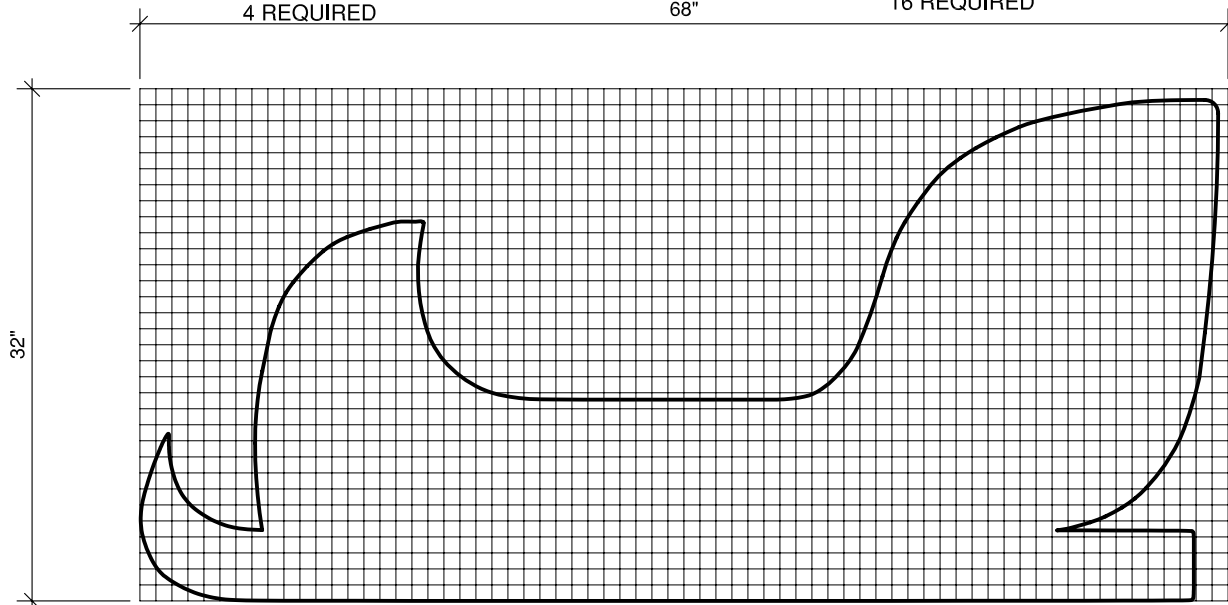

④
 CONTREPLAQUÉ 1/2"
 2 REQUIS
 1/2" PLYWOOD
 2 REQUIRED

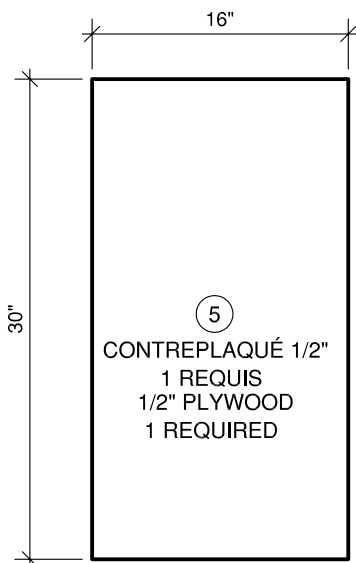

⑤
 CONTREPLAQUÉ 1/2"
 1 REQUIS
 1/2" PLYWOOD
 1 REQUIRED

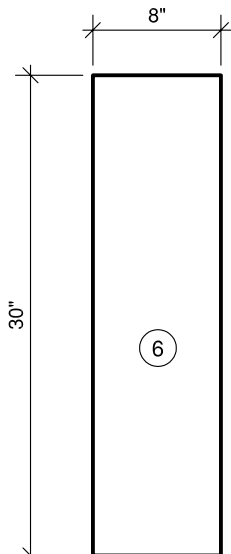

⑥
 CONTREPLAQUÉ 1/2"
 1 REQUIS
 1/2" PLYWOOD
 1 REQUIRED

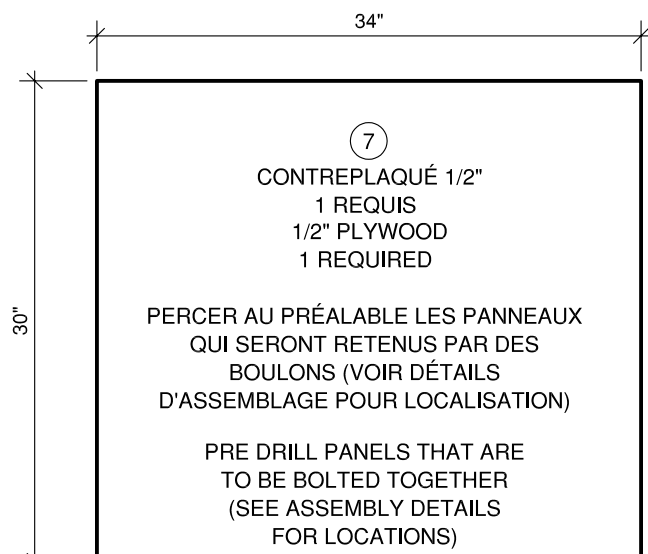

⑦
 CONTREPLAQUÉ 1/2"
 1 REQUIS
 1/2" PLYWOOD
 1 REQUIRED

 PERCER AU PRÉALABLE LES PANNEAUX
 QUI SERONT RETENUS PAR DES
 BOULONS (VOIR DÉTAILS
 D'ASSEMBLAGE POUR LOCALISATION)

 PRE DRILL PANELS THAT ARE
 TO BE BOLTED TOGETHER
 (SEE ASSEMBLY DETAILS
 FOR LOCATIONS)



NO PLAN / PLAN NO: PI-2002 / API-2002	FEUILLE / SHEET : 2/5
---	------------------------------------

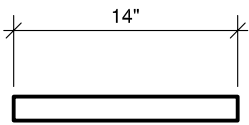

⑧
2 x 2
2 REQUIS
2 x 2
2 REQUIRED

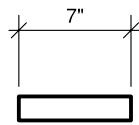

⑨
2 x 2
2 REQUIS
2 x 2
2 REQUIRED

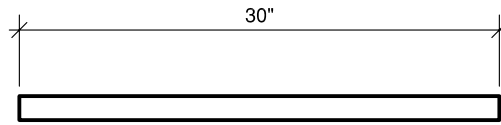

⑩
2 x 2
2 REQUIS
2 x 2
2 REQUIRED

PERCER AU PRÉALABLE LES PANNEAUX
QUI SERONT RETENUS PAR DES
BOULONS (VOIR DÉTAILS
D'ASSEMBLAGE POUR LOCALISATION)

PRE DRILL PANELS THAT ARE
TO BE BOLTED TOGETHER
(SEE ASSEMBLY DETAILS
FOR LOCATIONS)

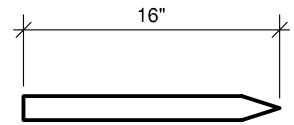

⑪
2 x 2
6 REQUIS
2 x 2
6 REQUIRED

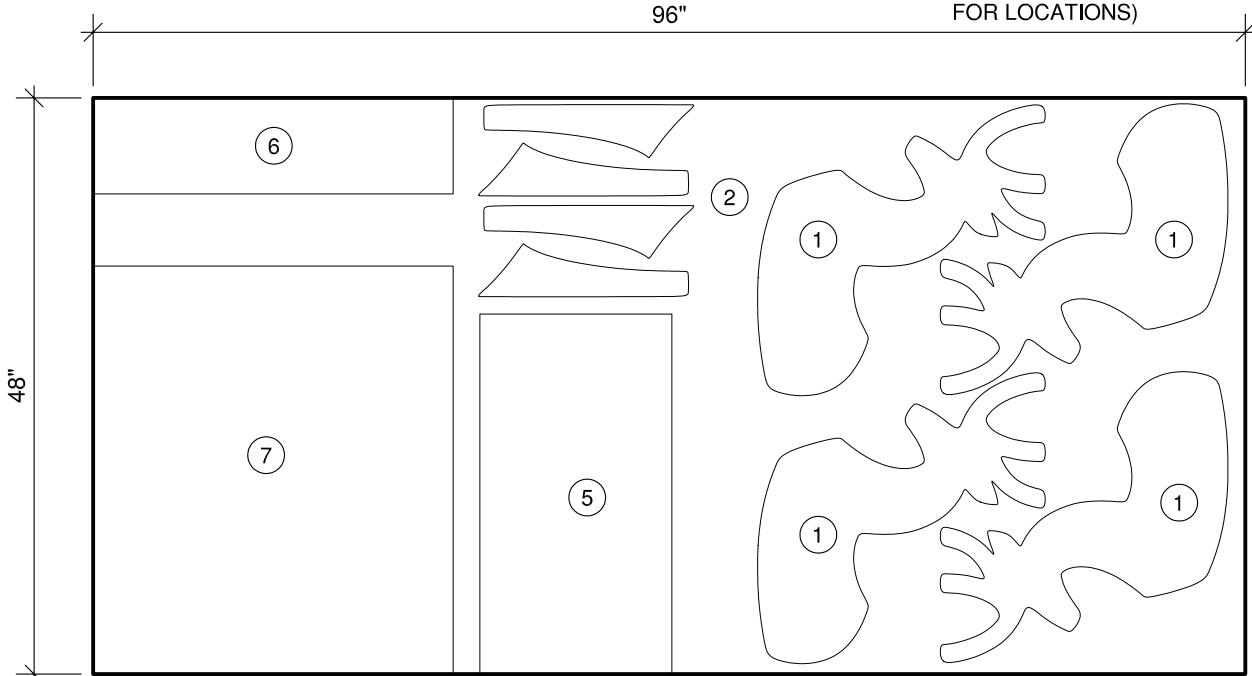

PLAN DE COUPE
CUTTING DIAGRAM
96"

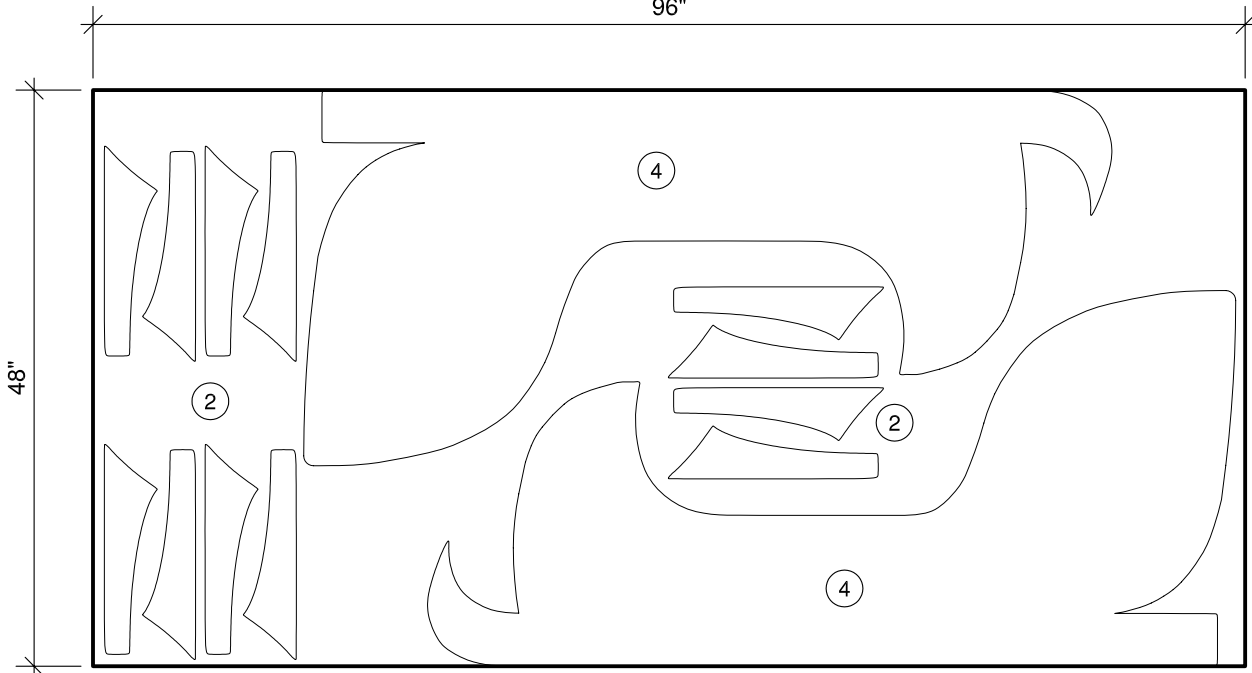

NO PLAN / PLAN NO:	FEUILLE / SHEET :
PI-2002 /	
API-2002	3/5

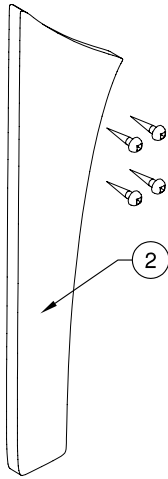
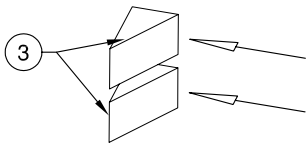

4 PATTES SONT REQUISES POUR
CHAQUE RENNE, 2 STANDARDS ET
2 INVERSÉES

4 LEGS REQUIRED PER
REINDEER, 2 STANDARD
AND 2 MIRRORED

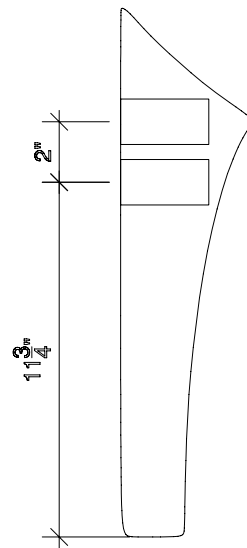

BOULONNER L'ASSEMBLAGE DU RENNE
ENSEMBLE AVEC DES BOULONS DE 4" ET
ÉCROUS À AILETTES, TRAVERSANT
LE CORPS ET LES 2 PATTES.
PERCER AU PRÉALABLE DES TROUS
AUX ENDROITS REQUIS.

BOLT REINDEER ASSEMBLY
TOGETHER WITH 4" BOLTS AND WING
NUTS, THROUGH LEGS ASSEMBLY
AND BODY. PRE DRILL HOLES
AT PROPER LOCATIONS.

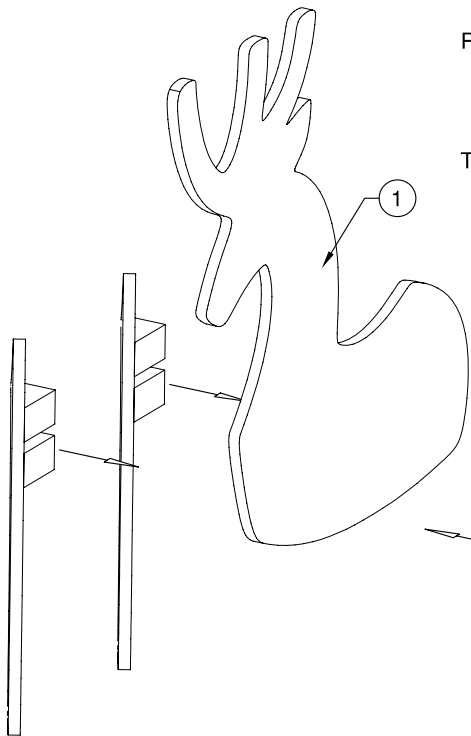

UTILISER DES PIQUETS DE BOIS
2 x 2, FIXÉS AU RENNES, ET ENFOUIS
DANS LE SOL, POUR RETENIR
L'ENSEMBLE EN PLACE.

USE 2 x 2 STAKES, FIXED TO REINDEERS
AND DRIVEN INTO THE GROUND, IN
ORDER TO RETAIN THE ASSEMBLY IN PLACE.

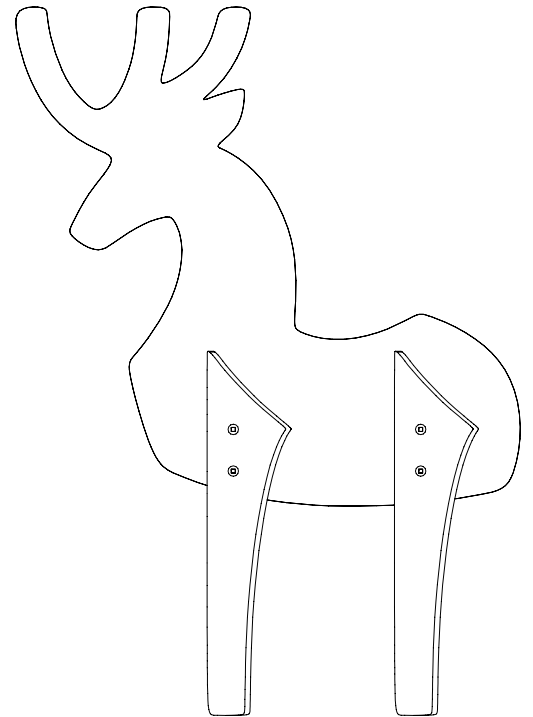
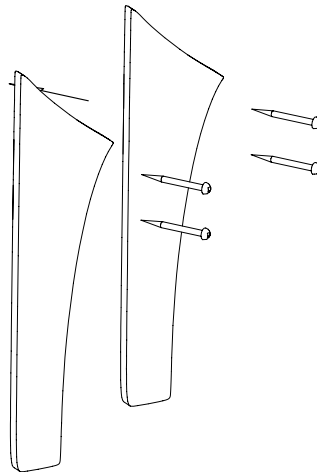

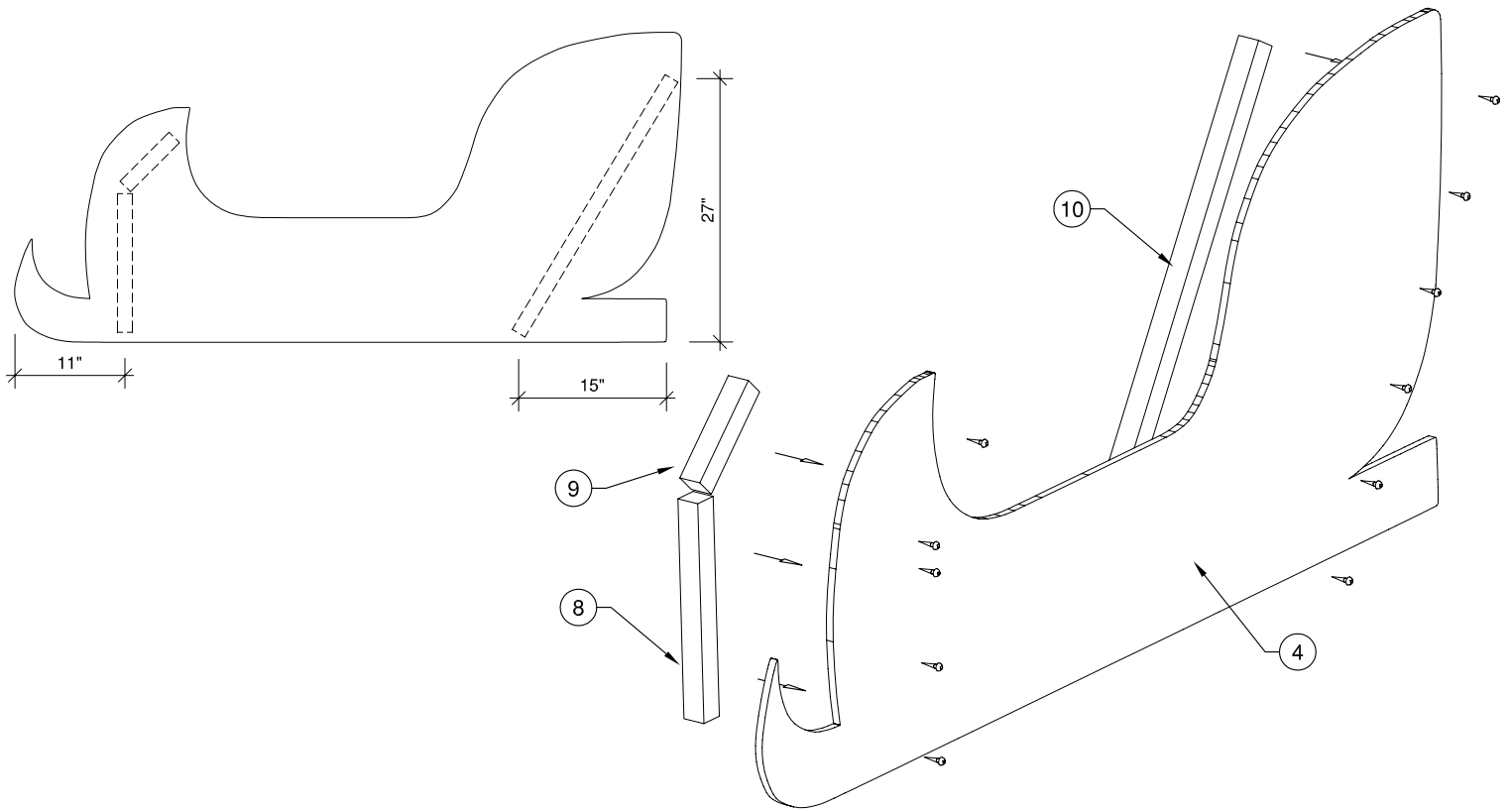

UTILISEZ DES BOULONS DE 3" AVEC
DES ÉCROUS À AILETTES POUR
ASSEMBLER LE TRINEAU AFIN
DE FACILITER LE DÉMONTAGE À
LA FIN DE LA SAISON

USE 3" CARRIAGE BOLTS WITH
WING NUTS TO ASSEMBLE THE
SLED, IN ORDER TO FACILITATE
DISASSEMBLY FOLOWING THE
CHRISTMAS SEASON

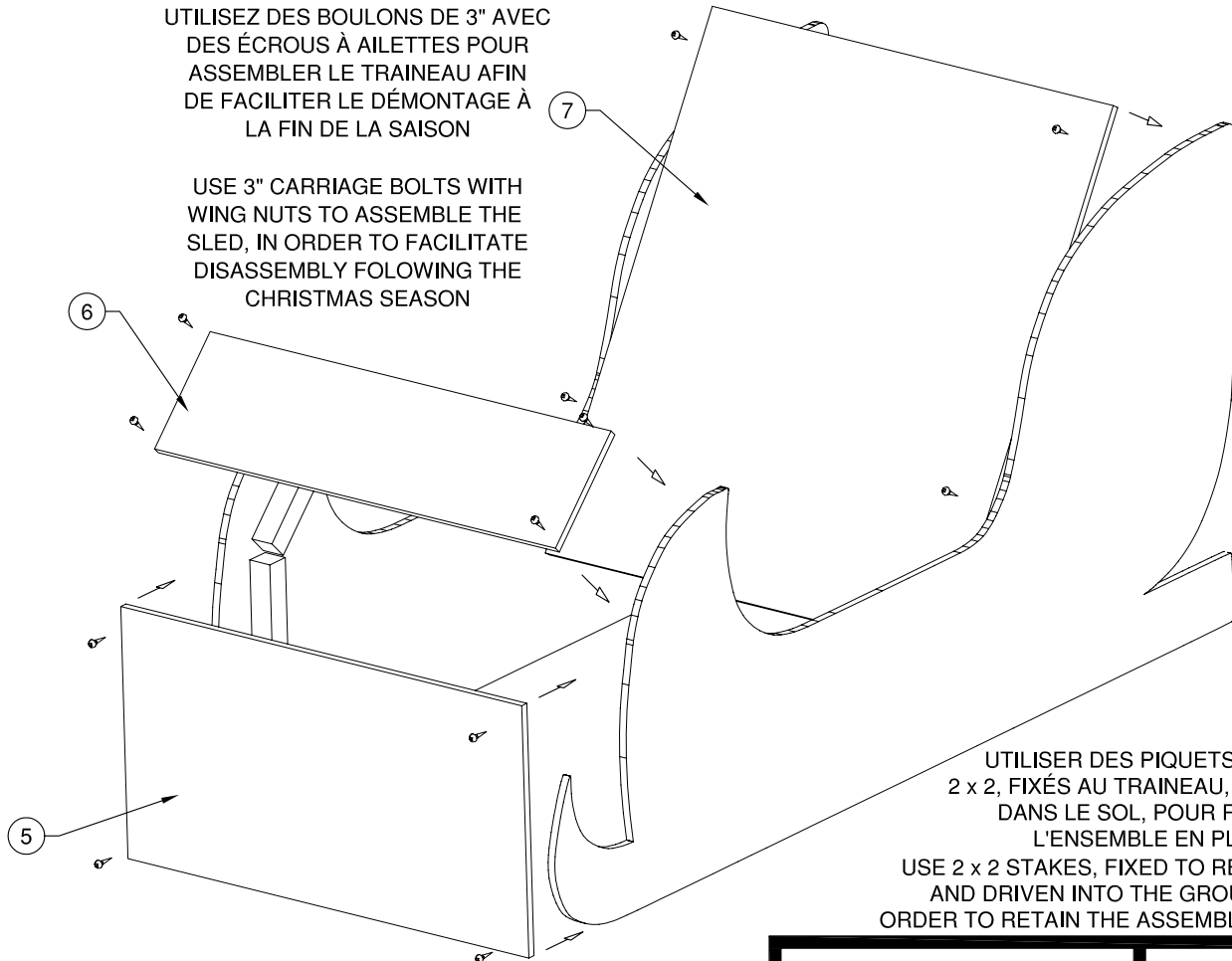

UTILISER DES PIQUETS DE BOIS
2 x 2, FIXÉS AU TRINEAU, ET ENFOUIS
DANS LE SOL, POUR RETENIR
L'ENSEMBLE EN PLACE.

USE 2 x 2 STAKES, FIXED TO REINDEERS
AND DRIVEN INTO THE GROUND, IN
ORDER TO RETAIN THE ASSEMBLY IN PLACE.



NO PLAN / PLAN NO:	FEUILLE / SHEET :
PI-2002 /	
API-2002	5/5

Devis quantitatif			
PI-2002		Quantité	
Description des articles	Localisation	Expédiée	De vente
Matériaux			
Contreplaqué select 1/2"	Structure	2.0 feuilles	64.00 pc
Épinette 2 x 2 x 8'	Structure	3.00 mcx	
Quincaillerie			
Vis à bois plaquées no.8 - 1 1/4"	Quincaillerie	100.00 mcx	
Boulons de carrosserie plaqués 3/16" x 3"	Quincaillerie	12.00 mcx	
Boulons de carrosserie plaqué 3/16" x 4"	Quincaillerie	16.00 mcx	
Rondelles plaquées 3/16"	Quincaillerie	28.00 mcx	
Écrous à ailettes plaqués 3/16"	Quincaillerie	28.00 mcx	

Quotation report			
API-2002		Quantity	
Item description	Location	Shipping	Pricing
Materials			
1/2" Select plywood	Structure	2.0 sheets	64.00 sqft
Spruce 2 x 2 x 8'	Structure	3.00 pieces	
Hardware			
1 1/4" No.8 nickel plated wood screws	Hardware	100.00 pieces	
3/16" x 3" Plated carriage bolts	Hardware	12.00 pieces	
3/16" x 4" Plated carriage bolts	Hardware	16.00 pieces	
3/16" Plated washers	Hardware	28.00 pieces	
3/16" Plated wing nuts	Hardware	28.00 pieces	