

# Instruction Manual



## P/N 30-0311 X-SERIES GAUGE OBD-II



### **STOP! - READ THIS BEFORE INSTALL OR USE!**

**WARNING:**

THIS INSTALLATION MAY REQUIRE WELDING OR INTEGRATION INTO A VEHICLE'S ELECTRICAL SYSTEM. DAMAGE TO SENSITIVE ELECTRONICS, FIRE, OR EXPLOSION MAY OCCUR IF PROPER PRECAUTION IS NOT TAKEN. IF THERE IS ANY DOUBT, **DO NOT** ATTEMPT THE INSTALLATION AND CONSULT A PROFESSIONAL.

**NOTE:** IT IS THE RESPONSIBILITY OF THE ENGINE TUNER TO ULTIMATELY CONFIRM THE CALIBRATION USE FOR ANY PARTICULAR ENGINE IS SAFE FOR ITS INTENDED USE. AEM HOLDS NO RESPONSIBILITY FOR ANY ENGINE DAMAGE THAT RESULTS FROM THE MISUSE OF THIS PRODUCT.

### Features

- 2-1/16" / 52mm outer diameter mounting
- Only model year 2008 and newer vehicles (CAN bus based OBD) supported
- 41 OBD-II parameters (PIDs) supported
- Read and clear Diagnostic Trouble Codes (DTCs)
- US or Metric / SI display modes
- Black bezel / faceplate supplied; Silver/white available as optional purchase
- Locking connectors
- Auto-dimming
- Supports vehicle/system voltages up to 16V

KIT CONTENTS	
PN	Description
10-0311	INST, X-SERIES OBD2 GAUGE
35-0311	GAUGE ASSY, X-SERIES OBD2 GAUGE
35-8618	NUT, KNURLED, M4x0.7 (2)
35-8614	BRACKET, X-SERIES GAUGE
35-8617	RUBBER BAND, X-SERIES GAUGE
35-3458	CABLE, X-SERIES GAUGE PWR/IO OBD2 V2

*OPTIONAL* ACCESSORIES	
PN	Description
30-0311-ACC	BEZEL, X-SERIES SILVER FACEPLATE, X-SERIES OBD2, WHITE

## Wiring Installation Diagram

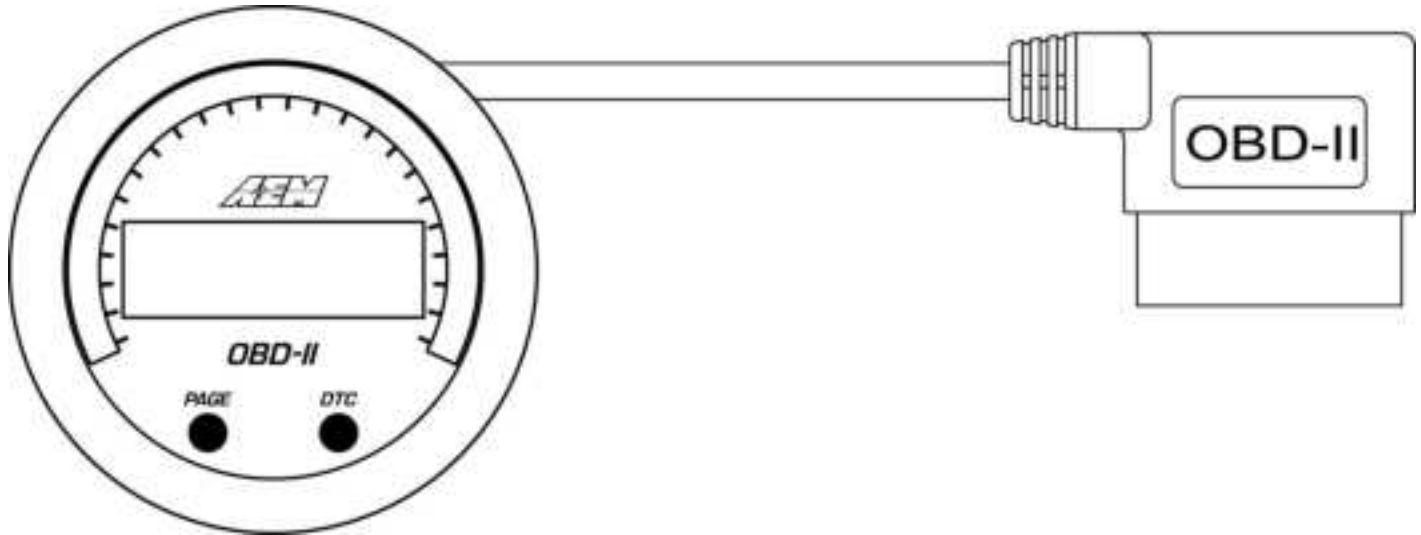

### Installation

The only wiring installation that is required is to plug the supplied OBD harness into your vehicle's OBD2 port. The port is located beneath the driver's side dash or in the driver's side kick panel and may be located beneath a removable cover or door. Please refer to your vehicle's service manual if you have trouble finding your port.

### Notes on 12V Supply

The 12V power available at your vehicle's OBD2 port is a permanent "always on" 12V -- no key switched power is available at this port. The AEM X-Series OBD2 Gauge uses a specific algorithm to detect when the key is on and the engine is started to wake up or go to sleep down, conserving power. The engine must be running for the gauge to remain on and display information.

NOTE: It is advised to unplug the gauge from the OBD port if the vehicle is to be stored for long periods of time to avoid excess drain on the battery. The gauge can consume up to 20mA while in sleep mode.

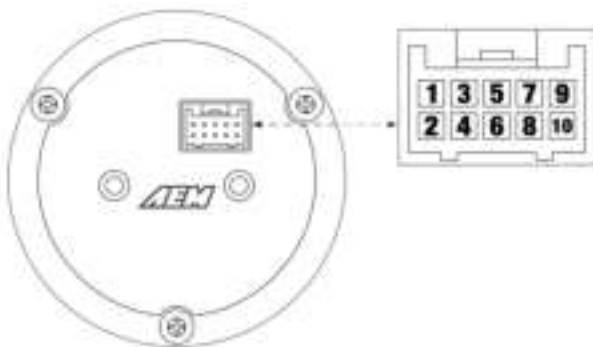

**Connector A - Power / IO**

Pin	Color	Description
1	WHITE	OBD2 / CANH
2	GREEN	OBD2 / CANL
3	RED	Switched 12V Power
4	BLACK	Power Ground
5 - 10	NC	NC

## Operation

### View Parameter IDs (PIDs)

Depress the PAGE button to scroll through the available OBD-II PIDs/parameters; an abbreviation of each parameter name will be briefly displayed after each button press.

The inner numeric LEDs and outer ring LED display the currently selected parameter reading. Please reference the supported OBD-II PID description table further on in this document. The gauge is capable of displaying all the PIDs listed in this table, however, the PID must be available on your specific vehicle. Not all PIDs are available on all vehicles.

PAGE and DTC buttons are located on the face of the gauge and are used to perform various functions, described below.

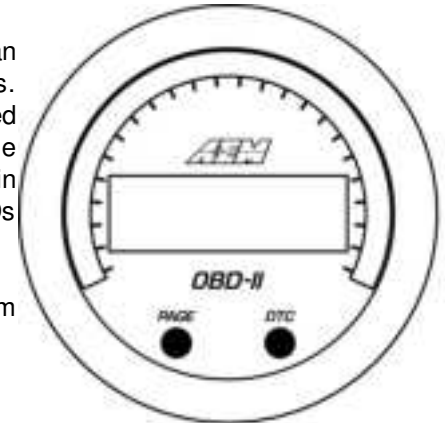

### Display or clear stored DTC (Diagnostic Trouble Codes)



- After pressing the DTC button, "dTC" will be briefly displayed.
- If no DTCs are available, "nonE" will be displayed.

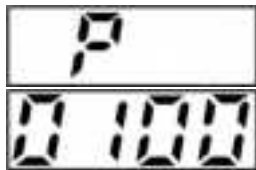

- If DTCs are available, the gauge will begin displaying the codes by briefly displaying the alphabetic prefix and then the numeric suffix.
- DTC codes have a standardized format; one letter followed by four numbers, e.g. P0030. You may look up their meaning by referring to your vehicle's factory service manual or using an online resource such as [www.obd-codes.com](http://www.obd-codes.com).
- For example, a P0030 code will be displayed as first "P" and then "0030".
- Briefly pressing the DTC button will scroll through the stored codes if there are more than one.



- Depress and hold the DTC button, while viewing the DTCs, to clear them.
- Some vehicles require the engine be off to clear codes. In this case, start the engine to wake up the gauge, turn off the engine but return the key to the "run" position so the ECU is on. Immediately after, follow the procedure to clear the DTCs before the gauge goes to sleep.
- Alternatively, if you don't wish to start the engine, you may unplug the gauge from the OBD port and plug it back in to wake up the gauge, turn the key to Run, and then follow the procedure to clear DTCs.

- The gauge will return to normal display mode a few seconds after the last button press

### Change display units US / SI (metric)

- The gauge should be in its normal display mode, showing the current parameter reading
- Depress and hold both the PAGE button for three seconds until US or SI appears
- Press the PAGE button to toggle between US or SI (metric) modes
- The gauge will return to normal display mode a few seconds after the last button press

## Faceplate / Bezel Installation

The gauge kit is supplied assembled with a black faceplate and black bezel. An accessory kit is available (for purchase through AEM dealers) which includes an optional silver bezel and white faceplate. Please reference the Optional Accessories section earlier in the document for the appropriate part numbers. Contact your dealer or visit [www.aemelectronics.com](http://www.aemelectronics.com) for more information.

The faceplate may be reversible, displaying alternative scalings on either side. Reference the Operation section of this manual for details on how to switch the display mode when reversing the faceplate. Disassembly is required to change the faceplate, flip/reverse the faceplate, or change the bezel of the gauge. The following diagram will provide familiarization with the major components of the gauge prior to beginning the procedure.

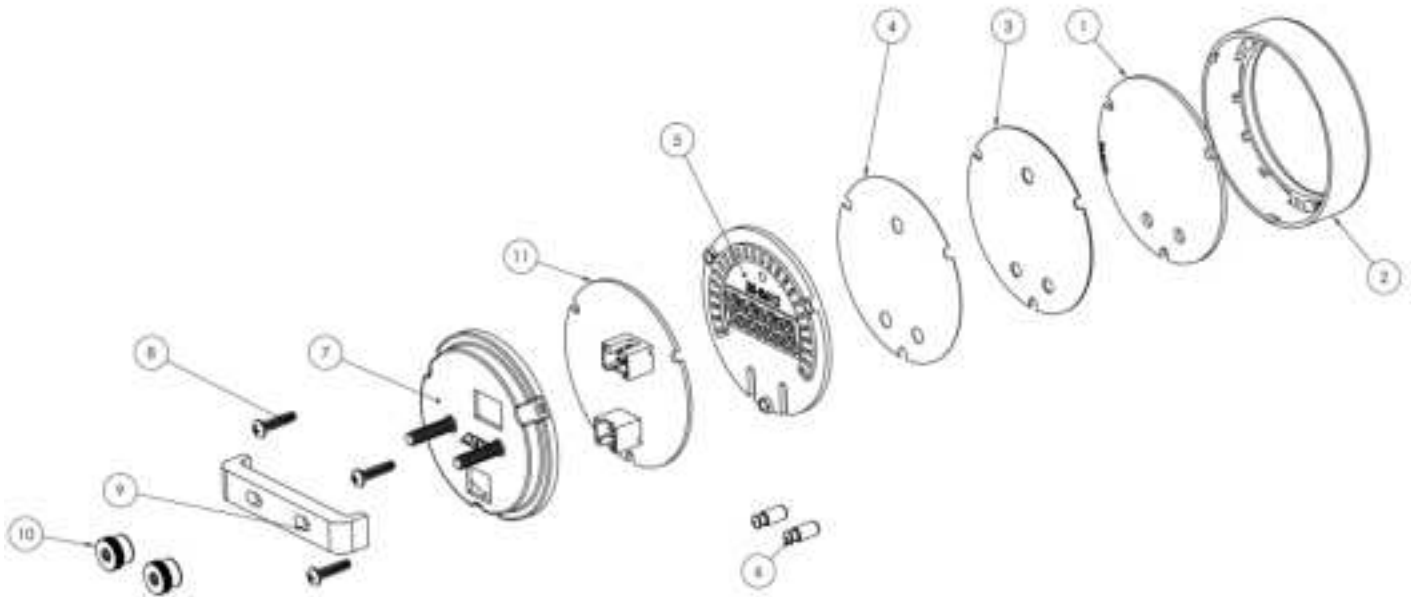

Item	Qty	Description
1	1	Lens
2	1	Bezel
3	1	Faceplate
4	1	Diffuser
5	1	Light Guide
6	2	Button
7	2	Mounting Stud (M4 x 0.7)
8	3	Assembly Screw
9	1	Mounting Bracket
10	2	Brass Thumb Screw (M4 x 0.7)
11	1	Printed Circuit Board (PCB)

## Gauge Disassembly

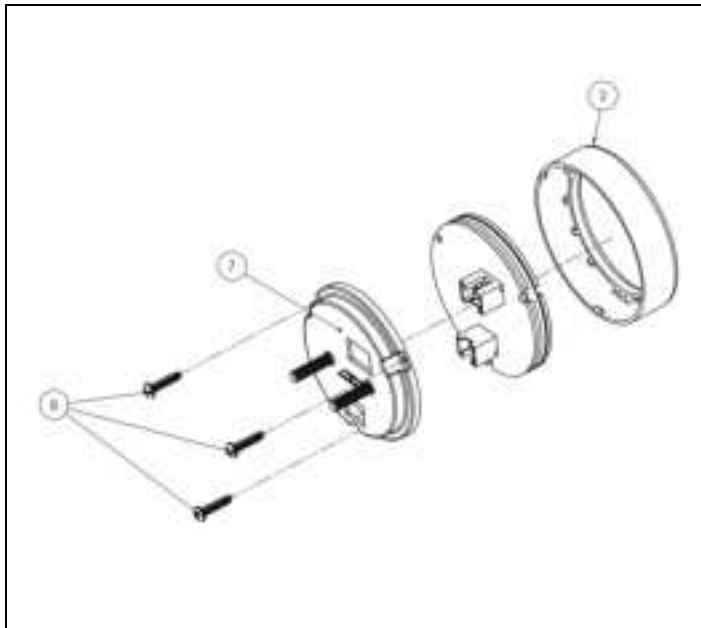

**STEP 1** - Remove the three assembly screws (8) using a #1 Phillips head screwdriver. Separate the bezel (2) and cup (7) from the rest of the assembly. If you have purchased the optional accessory kit, the silver bezel may be replaced for the existing bezel at this time

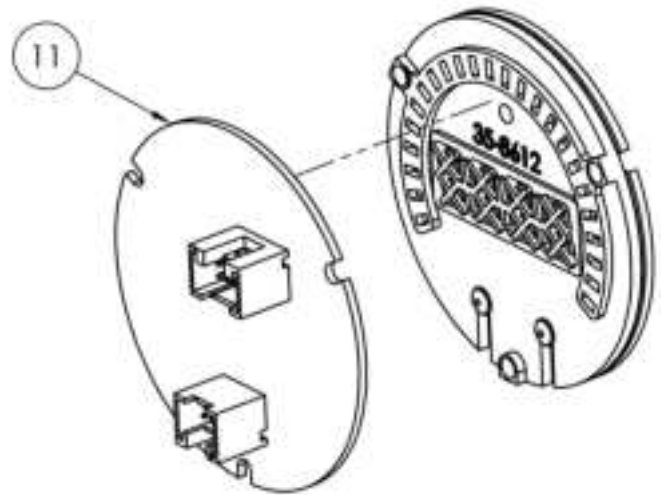

**STEP 2** - Separate the PCB (11) from the remaining components

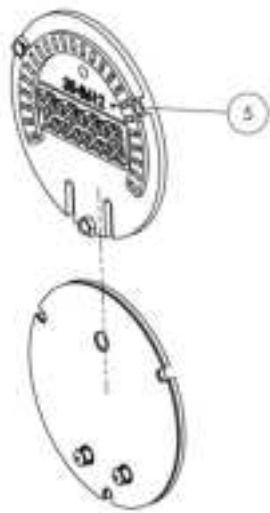

**STEP 3** - Slide the light guide (5) upward to remove it, the buttons may fall out at this time - take care not to lose them

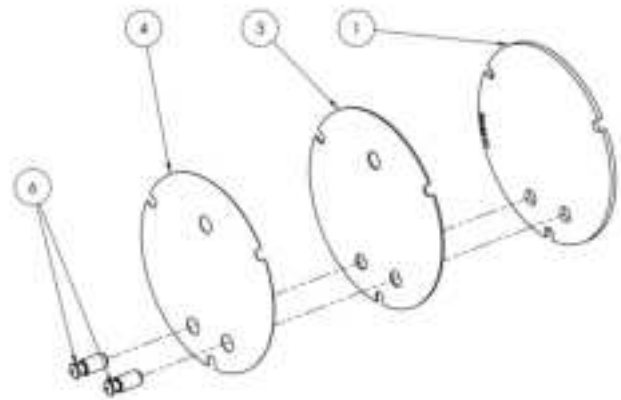

**STEP 4** - As you separate the remaining components, diffuser (4), faceplate (3), lens (1), note the order in which they were assembled. The faceplate (3) may now be reversed to display an alternate scaling or replaced for a different color as included in the optional accessory kit

## Gauge Assembly

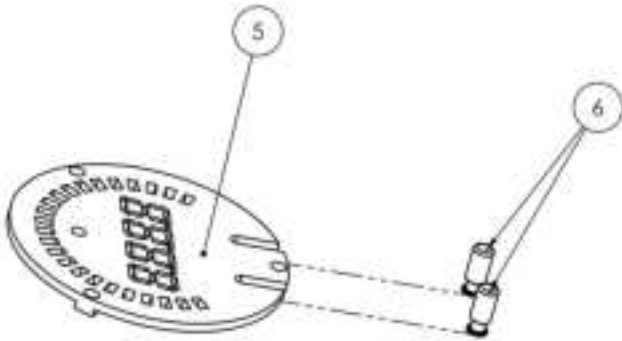

**STEP 1** - Place the light guide (5) on a flat surface (black side up) and slide the buttons (6) into the slots

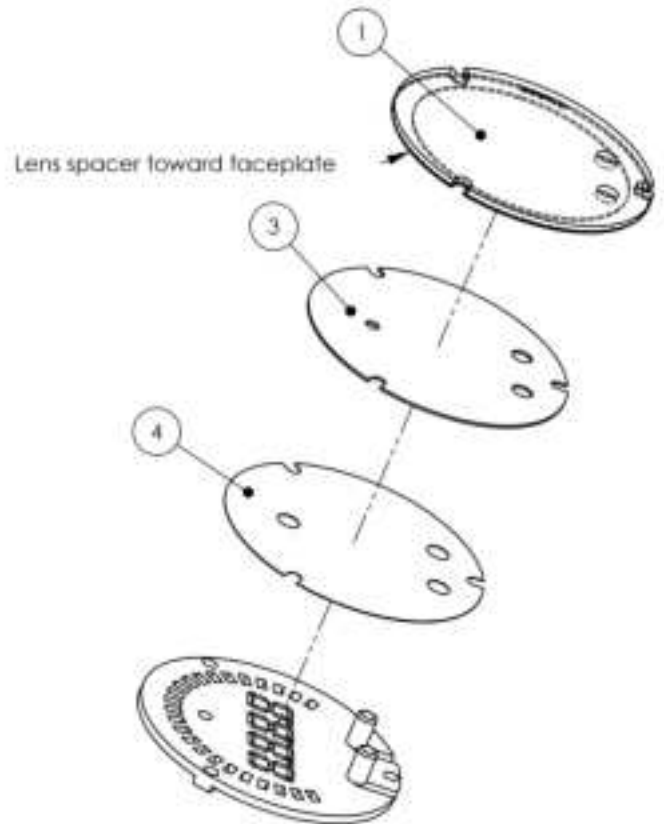

**STEP 2** - Stack the diffuser (4), faceplate (3), and lens (1) in order, over the buttons, and on to the light guide

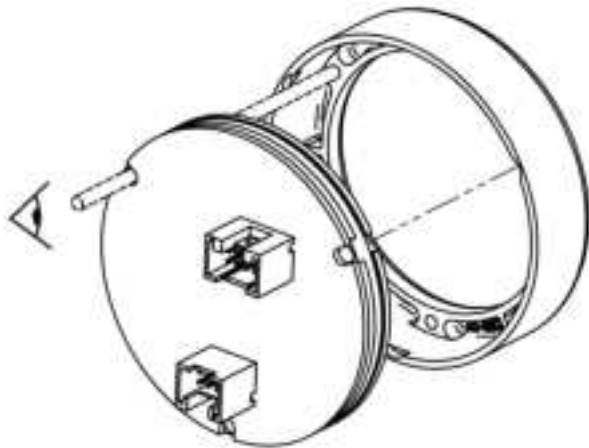

**STEP 3** - Reassemble the PCB and display stack with the bezel, making sure screw holes are aligned through the entire assembly

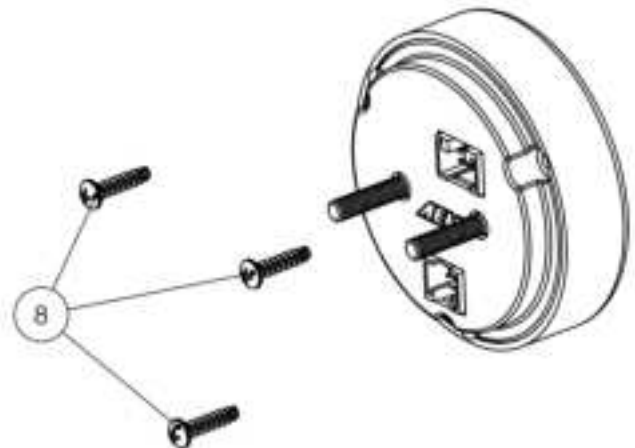

**STEP 4** - Reassemble and tighten screws to 2 in-lb (previously assembled bezel) or 3 in-lb (new bezel). **Do not over-tighten!**

## Gauge Installation

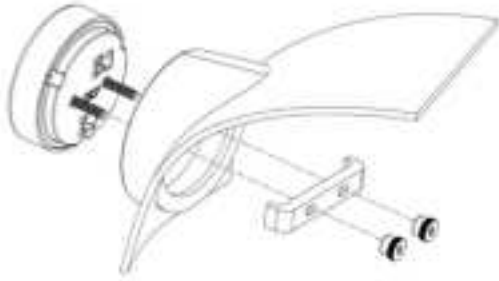

Installation using supplied bracket

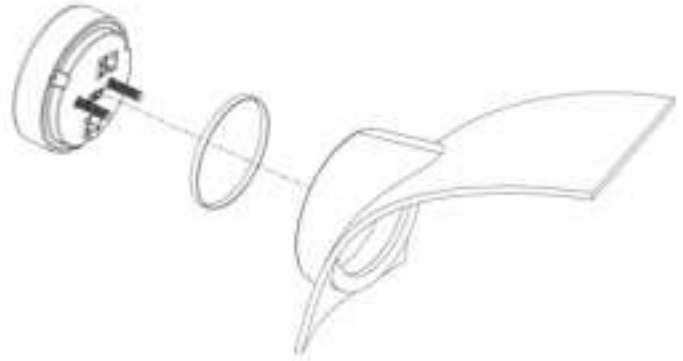

Installation without bracket, using rubber band

A 2-1/6" (52mm) hole is required to mount the X-Series gauge. A bracket and thumbscrews are provided to facilitate installation into a panel or gauge pod. In some cases, the gauge cup may be pushed into a mounting hole causing an interference fit strong enough to retain the gauge; the supplied rubber band may be fit to the gauge to create a tighter fit in mounting holes slightly larger than 52mm. It is, however, recommended that gauges be mounted securely using the supplied bracket to ensure they never become loose and cause a hazard during vehicle operation.

**Note:** The gauge is not water-proof and should not be installed in a location with exposure to water or snow. Damage caused by water ingress will not be covered under warranty.

## OBD-II Parameter IDs (PIDs)

PID (hex)	Display Label	Description	US	SI	Notes
10	A FLo	MAF air flow rate	lb/min	g/sec	
0F	A ir t	Intake air temp	degF	degC	
46	A ir t	Ambient air temp	degF	degC	
68	A ir t	Intake air temp sensor	degF	degC	If \$0F is n/a
33	bAr0	Barometric pressure (abs)	psi	kPa	
42	bAtt	Control Module Voltage	V	V	
05	CL t	Engine coolant temp	degF	degC	
23	d Pr5	Fuel Rail Pr (die or gdi)	kpsi	bar	If \$0A & \$22 are n/a
59	d Pr5	Fuel Rail Pr (die or gdi)	kpsi	bar	
6D	d Pr5	Fuel Rail Pr (die or gdi)	kpsi	bar	
78	EGt .1	EGT Bank 1	degF	degC	B1S1 only
79	EGt .2	EGT Bank 2	degF	degC	B2S1 only
0C	E SPD	Engine RPM	rpm	rpm	
52	Eth	Ethanol fuel %	%	%	
66	FLo	Mass air flow sensor	lb/min	g/sec	FLOA + FLOB (if supp)
2F	F LUL	Fuel Level Input	%	%	
0A	F Pr5	Fuel pressure (gauge)	psi	bar	
22	F Pr5	Fuel Rail Pr (rel to map)	psi	bar	If \$0A & \$23 are n/a
5E	F r tE	Engine fuel rate	ga/hr	liter/hr	
5B	H bAt	Hybrid Battery Charge	%	%	
03	Loop	Fuel system status	n/a	n/a	"OL" = Open Loop / "CL" = Closed Loop
0E	Ign	Timing advance	degBTDC	degBTDC	-Negative sign indicates retard e.g. "-10" = 10 degATDC
0B	Int P	Intake Manifold press (abs)	psi	kPa	
70	Int P	Boost pressure control	psi	kPa	Gauge pressure
87	Int P	Intake man abs press	psi	kPa	If \$0B is n/a
24	LR .1	O2S1_WR lambda(1)	AFR	Lambda	

34	LR .1	O2S1 WR lambda(1)	AFR	Lambda	If \$24 is n/a
28	LR .2	O2S5 WR lambda(1)	AFR	Lambda	
38	LR .2	O2S5 WR lambda(1)	AFR	Lambda	If \$28 is n/a
07	L FE .1	LT fuel % trim—Bank 1	%	%	-Negative = Lean / +Positive = Rich
09	L FE .2	LT fuel % trim—Bank 2	%	%	-Negative = Lean / +Positive = Rich
04	LoRd	Calculated engine load	%	%	
5C	o iL t	Engine oil temp	degF	degC	
06	S FE .1	ST fuel % trim—Bank 1	%	%	-Negative = Lean / +Positive = Rich
14	S FE .1	Bank 1, Sensor 1: STFT	%	%	-Negative = Lean / +Positive = Rich, If \$06 is n/a
08	S FE .2	ST fuel % trim—Bank 2	%	%	-Negative = Lean / +Positive = Rich
18	S FE .2	Bank 2, Sensor 1: STFT	%	%	-Negative = Lean / +Positive = Rich, If \$08 is n/a
62	t o r q	Actual Engine - Percent Torque	%	%	
11	t P S	Throttle position	%	%	$\% = ( \text{TPS Voltage} / 5.0\text{V} ) * 100$
45	t P S	Relative throttle position	%	%	$\% = ( (\text{TPS Voltage} - \text{Closed TPS Voltage}) / 5.0\text{V} ) * 100$
44	t r LR	Command eq ratio	AFR	Lambda	
0D	U S S	Vehicle speed	mph	kph	

## FAQ / Troubleshooting

**I installed my gauge correctly and the display just shows dashes, "----", or keeps going dark, turning the display off**

- o Make sure the OBD-II connector is firmly seated into the car's OBD-II port
- o Make sure that your car is fitted with an OEM ECU that supports OBD-II over CAN. This is federally mandated for US vehicles 2008 and newer, however some older cars may have adopted CAN in earlier model years.
- o Most vehicles require the key to be in the 'Run' position such that the OEM ECU is powered on and sending OBD-II data to the gauge.
- o The engine must be started and remain running for the gauge to remain "awake."
- o Make sure that the AEM OBD-II gauge is the only OBD-II device/scanner that is connected to the vehicle. Multiple devices on the bus may cause unexpected functionality.

**This manual says that a PID is supported but I can't find it when I scroll through the PID list using the PAGE button.**

Your vehicle may not support every PID that is supported by the AEM OBD-II gauge. Upon power-up, the gauge will query the vehicle for a list of the available PIDs and display the ones which are supported by the gauge. If the PID is not listed when scrolling through the list using the PAGE button, then the PID is not supported by your vehicle.

**My gauge is displaying DTC (Diagnostic Trouble Codes) but I don't know what they mean.**

DTC codes have a standardized format; one letter followed by four numbers, e.g. P0030. You may look up their meaning by referring to your vehicle's factory service manual or using an online resource such as [www.obd-codes.com](http://www.obd-codes.com).

**My check engine light is on or my other OBD-II scanner says I have a DTC but the gauge reports "none" when I depress the DTC button.**

The OBD-II specification sets forth a distinction between "pending" trouble codes and "stored" trouble codes. The AEM OBD-II gauge will only display "stored" trouble codes. Please refer to your factory service manual or SAE specification for further information on "pending" codes. The gauge's DTC clear function will, however, reset ALL codes, both pending and stored.

**I followed the procedure to clear my DTC, the gauge said "CLr" but the light remains on and I still have codes.**

Some vehicles require the engine be off to clear codes. In this case, start the engine to wake up the gauge, turn off the engine but return the key to the "run" position immediately so the ECU is on and transmitting CAN data to the gauge. Immediately after, follow the procedure to clear the DTCs before the gauge goes to sleep. Alternatively, if you don't wish to start the engine, you may unplug the gauge from the OBD port and plug it back in to wake up the gauge, turn the key to Run, and then follow the procedure to clear DTCs.

**My gauge seems to take a long time to turn on/off.**



The 12V power available at your vehicle's OBD2 port is a permanent "always on" 12V, no key switched power is available at this port. The AEM X-Series OBD2 Gauge uses a specific algorithm to detect when the key is on and the engine is started to boot up or shut down, conserving power. The engine must be running for the gauge to remain on and booted up. **NOTE: It is advised to unplug the gauge from the OBD port if the vehicle is to be stored for long periods of time to avoid excess drain on the battery.**

#### What pins are used in the connector?

To populate optional extras, use JST P/N SPUD-001T-P0.5 terminals for 22-26 AWG wire.

*For support, contact AEM Technical Support at 1-800-423-0046 or [gentech@aemelectronics.com](mailto:gentech@aemelectronics.com).*

## Specifications

<b>Dimensions</b>	diameter (bezel)	2.40	in
	diameter (cup)	2-1/16	in
	depth (incl. bezel)	0.825	in
	depth (cup only)	0.200	in
<b>Supply Voltage</b>	min	10	VDC
	max	18	VDC
<b>Supply Current (13.8V)</b>	nominal	50.0	mA
<b>Operating Temperature</b>	min	-4 / -20	degF / degC
	max (16V Supply)	185 / 85	degF / degC

## 12 Month Limited Warranty

Advanced Engine Management Inc. warrants to the consumer that all AEM High Performance products will be free from defects in material and workmanship for a period of twelve (12) months from date of the original purchase. Products that fail within this 12-month warranty period will be repaired or replaced at AEM's option, when determined by AEM that the product failed due to defects in material or workmanship. This warranty is limited to the repair or replacement of the AEM part. In no event shall this warranty exceed the original purchase price of the AEM part nor shall AEM be responsible for special, incidental or consequential damages or cost incurred due to the failure of this product. Warranty claims to AEM must be transportation prepaid and accompanied with dated proof of purchase. This warranty applies only to the original purchaser of product and is non-transferable. All implied warranties shall be limited in duration to the said 12-month warranty period. Improper use or installation, accident, abuse, unauthorized repairs or alterations voids this warranty. AEM disclaims any liability for consequential damages due to breach of any written or implied warranty on all products manufactured by AEM. Warranty returns will only be accepted by AEM when accompanied by a valid Return Merchandise Authorization (RMA) number. Product must be received by AEM within 30 days of the date the RMA is issued.

UEGO oxygen sensors are considered wear items and are not covered under warranty.

Please note that before AEM can issue an RMA for any electronic product, it is first necessary for the installer or end user to contact the EMS tech line at 1-800-423-0046 to discuss the problem. Most issues can be resolved over the phone. Under no circumstances should a system be returned or a RMA requested before the above process transpires.

AEM will not be responsible for electronic products that are installed incorrectly, installed in a non-approved application, misused, or tampered with.

Any AEM electronics product can be returned for repair if it is out of the warranty period. There is a minimum charge of \$50.00 for inspection and diagnosis of AEM electronic parts. Parts used in the repair of AEM electronic components will be extra. AEM will provide an estimate of repairs and receive written or electronic authorization before repairs are made to the product.