



“The Gambit Dress”

Sizes 0/2 to 28/30

Stop!

Print just this page first to check accuracy. The Mood square to the left should measure 2 inches. Print “actual size” (no scaling).

#MoodGambitPattern



1

SIZE 28/30

SIZE 24/26

SIZE 20/22

SIZE 16/18

SIZE 12/14

SIZE 8/10

SIZE 4/6

SIZE 0/2



2

3

4

5

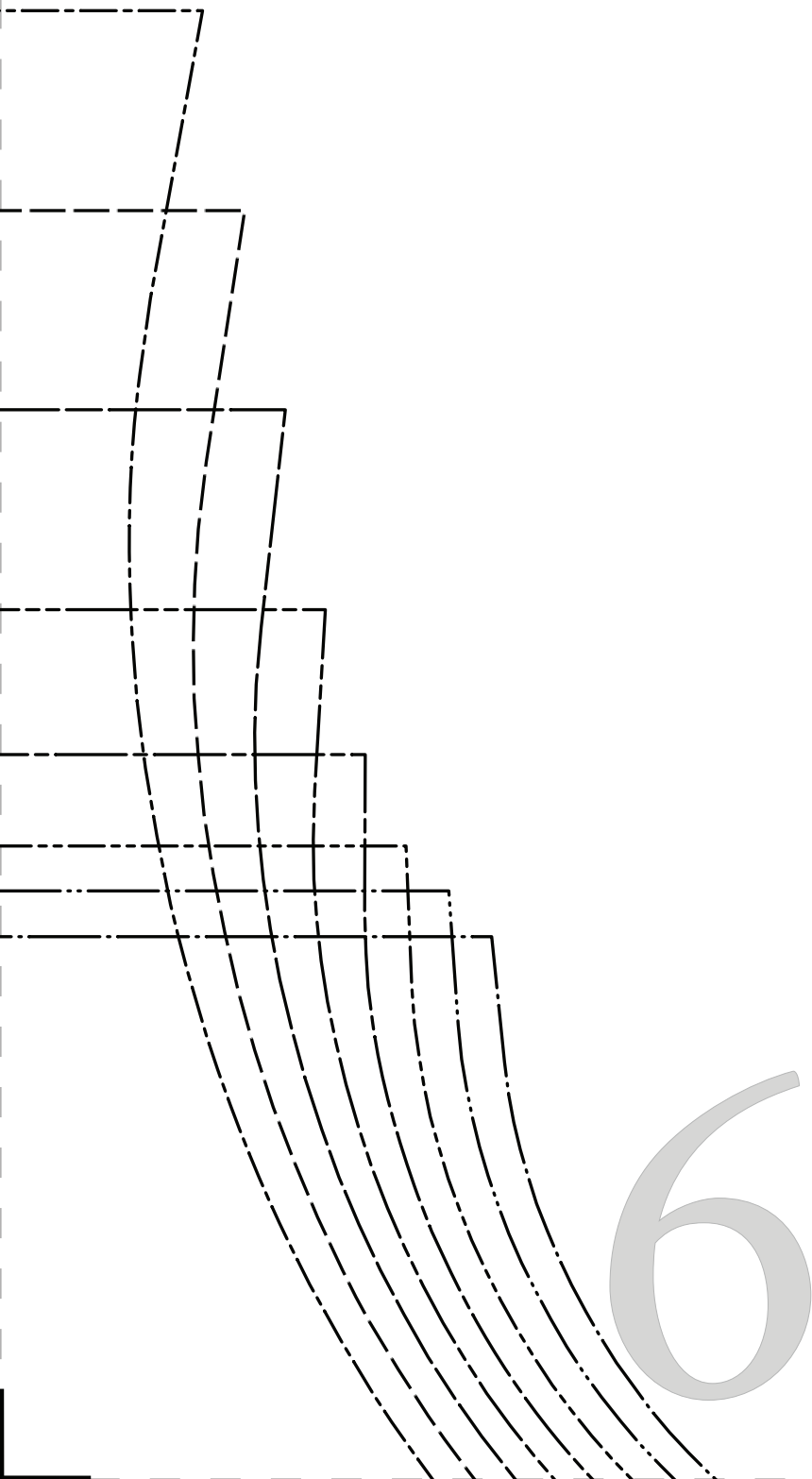

GRAINLINE



T

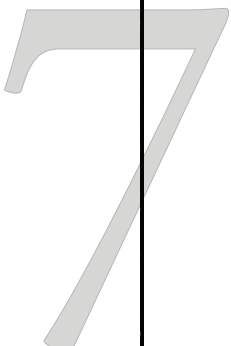

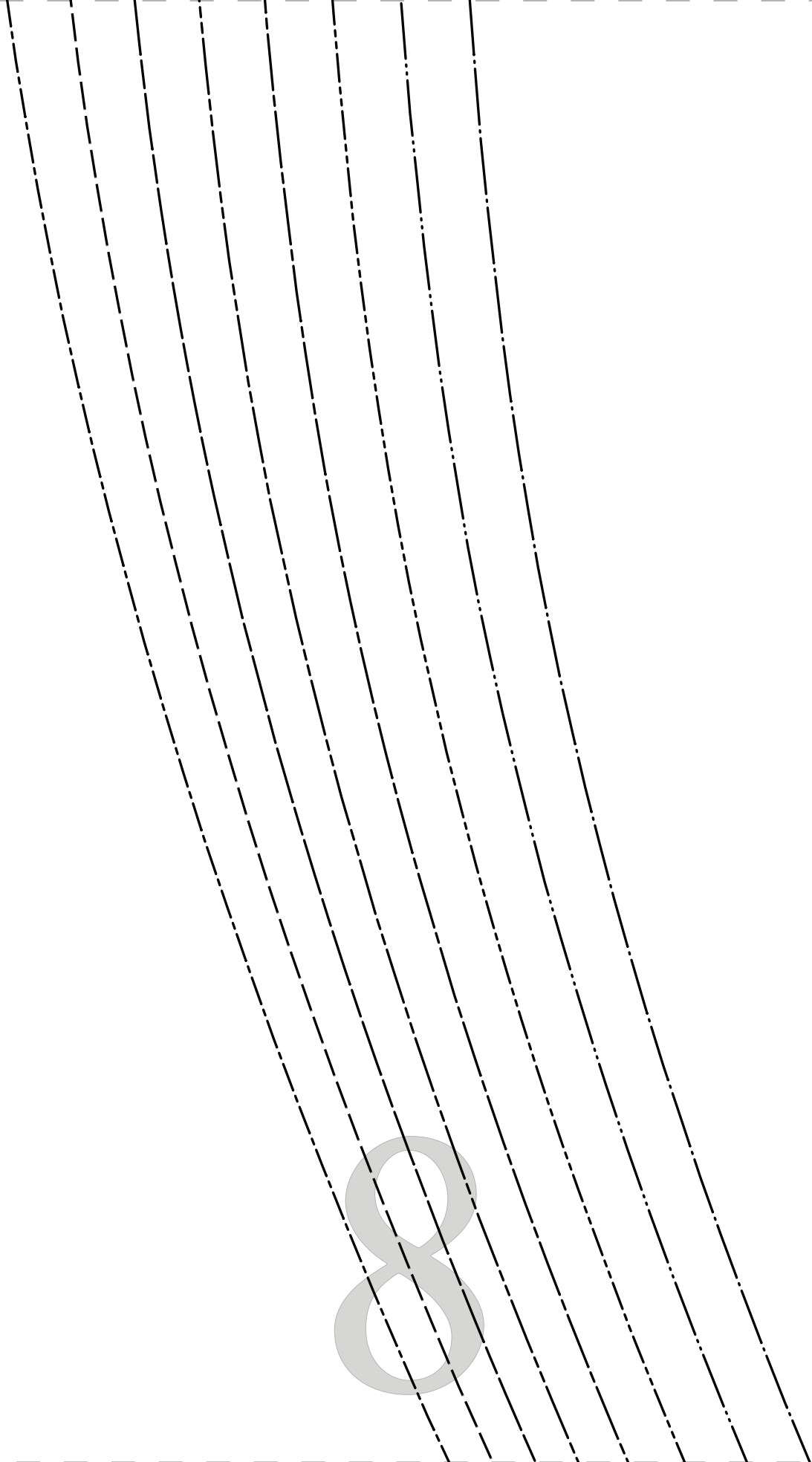

88

9

P

W

DE

#Mood

“The G

10

DR

CUT 1 ON

CUT

FAC

PATTERNS

BY

maud

DESIGNER FABRICS

MDF239

GambitPattern

Gambit Dress”

MDF023

DRESS SKIRT

FOLD FOR FRONT

2 FOR BACK

1 TO FACE

1 1

12

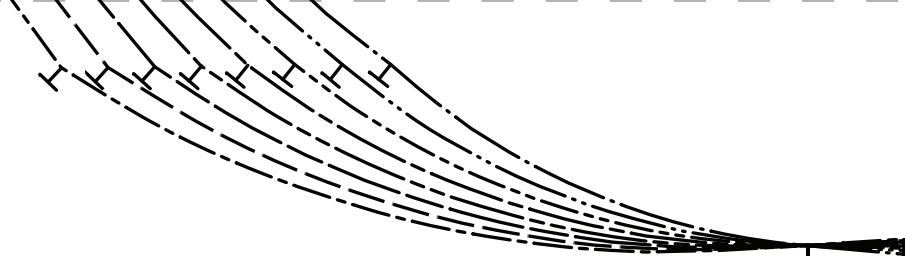

“The Gambit Dress”
MDF023
SHIRT FACING
CUT 2 OF FABRIC
FACE TO FACE

#MoodGambitPattern



1 3

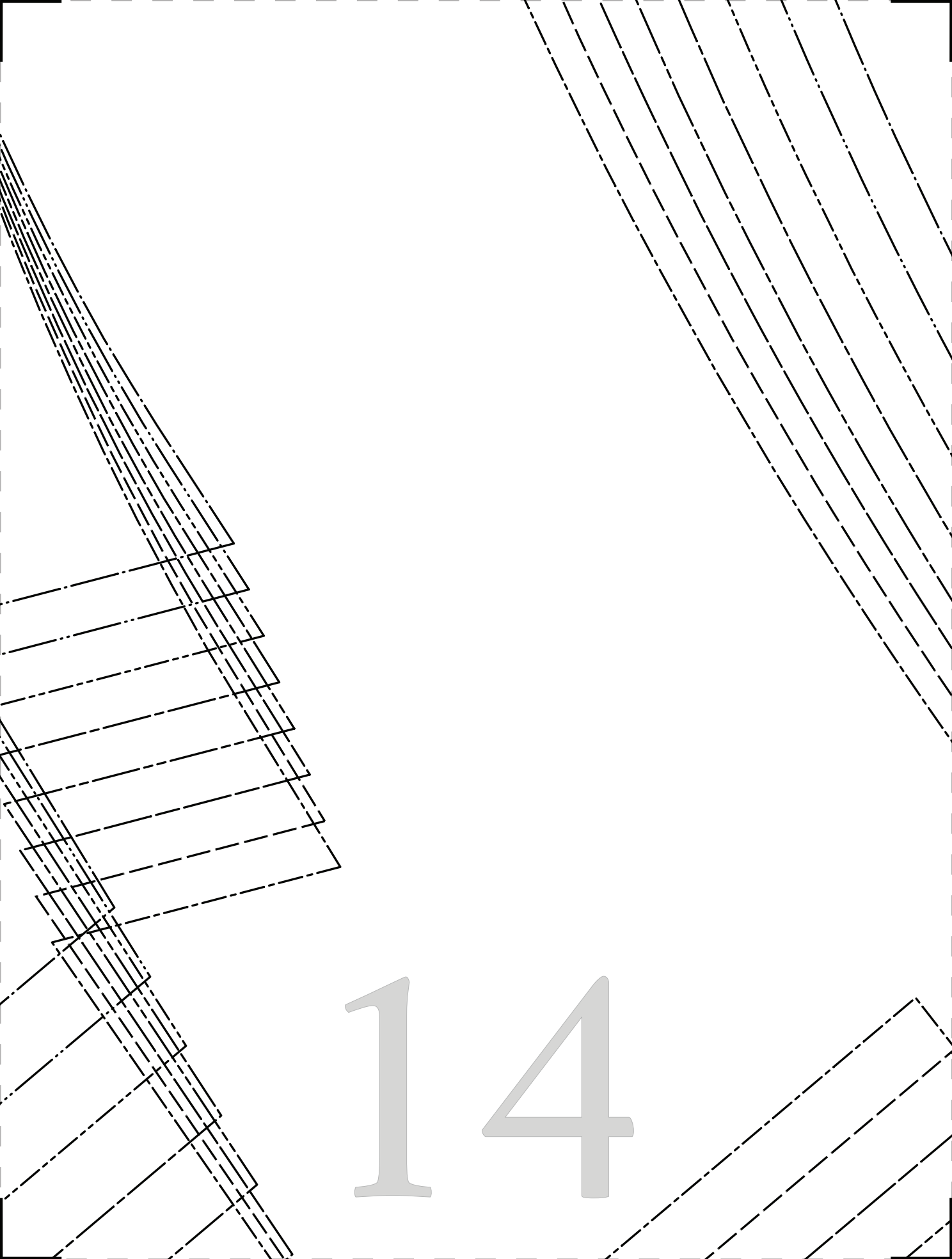

14

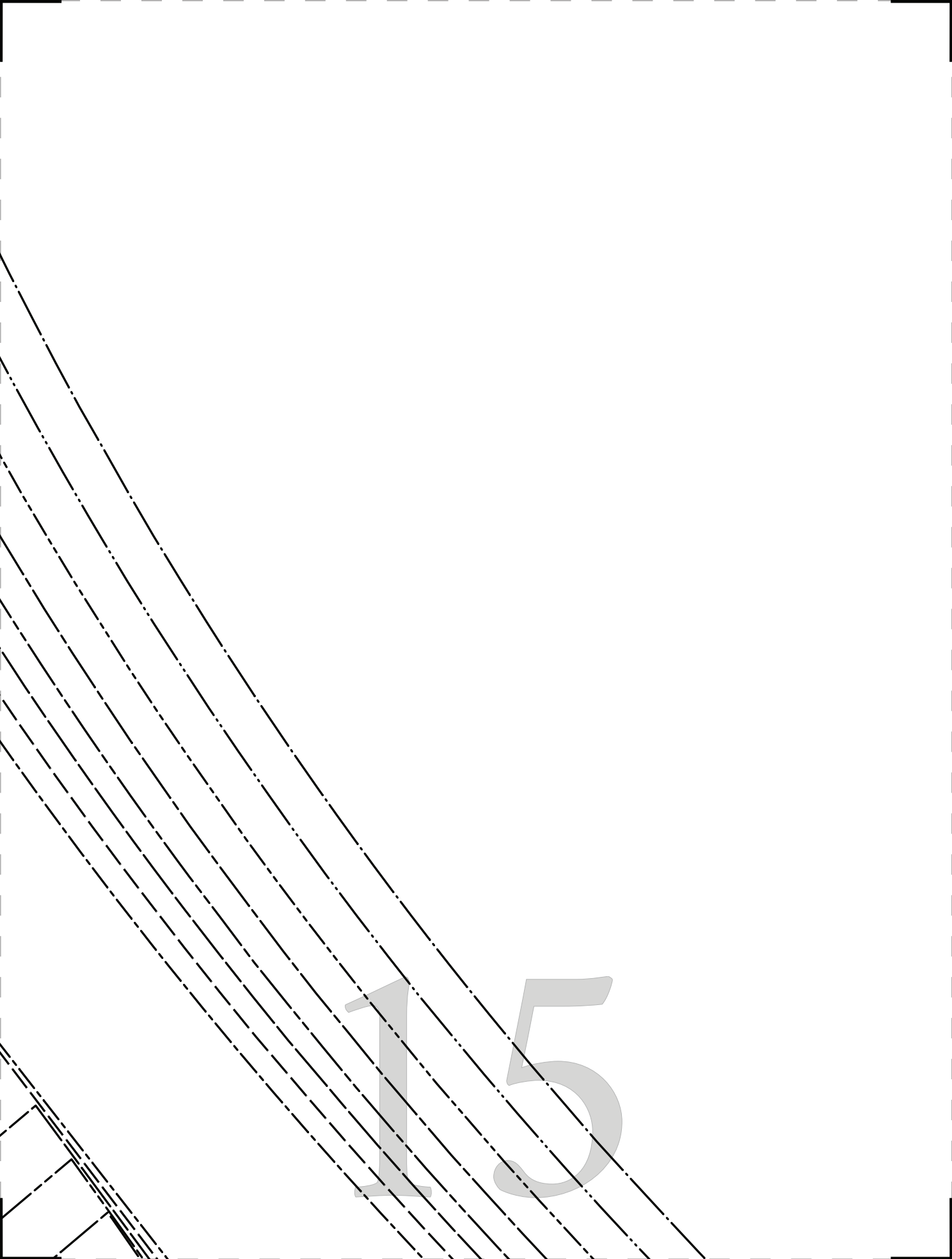

SIZ
SIZ
SIZ
SIZ
SIZ
SIZ
SIZ
SIZ

16

E 0/2
E 4/6
E 8/10
E 12/14
E 16/18
E 20/22
E 24/26
E 28/30

17

GRAINLINE

18

PLACE ON FOLD OF FABRIC



19

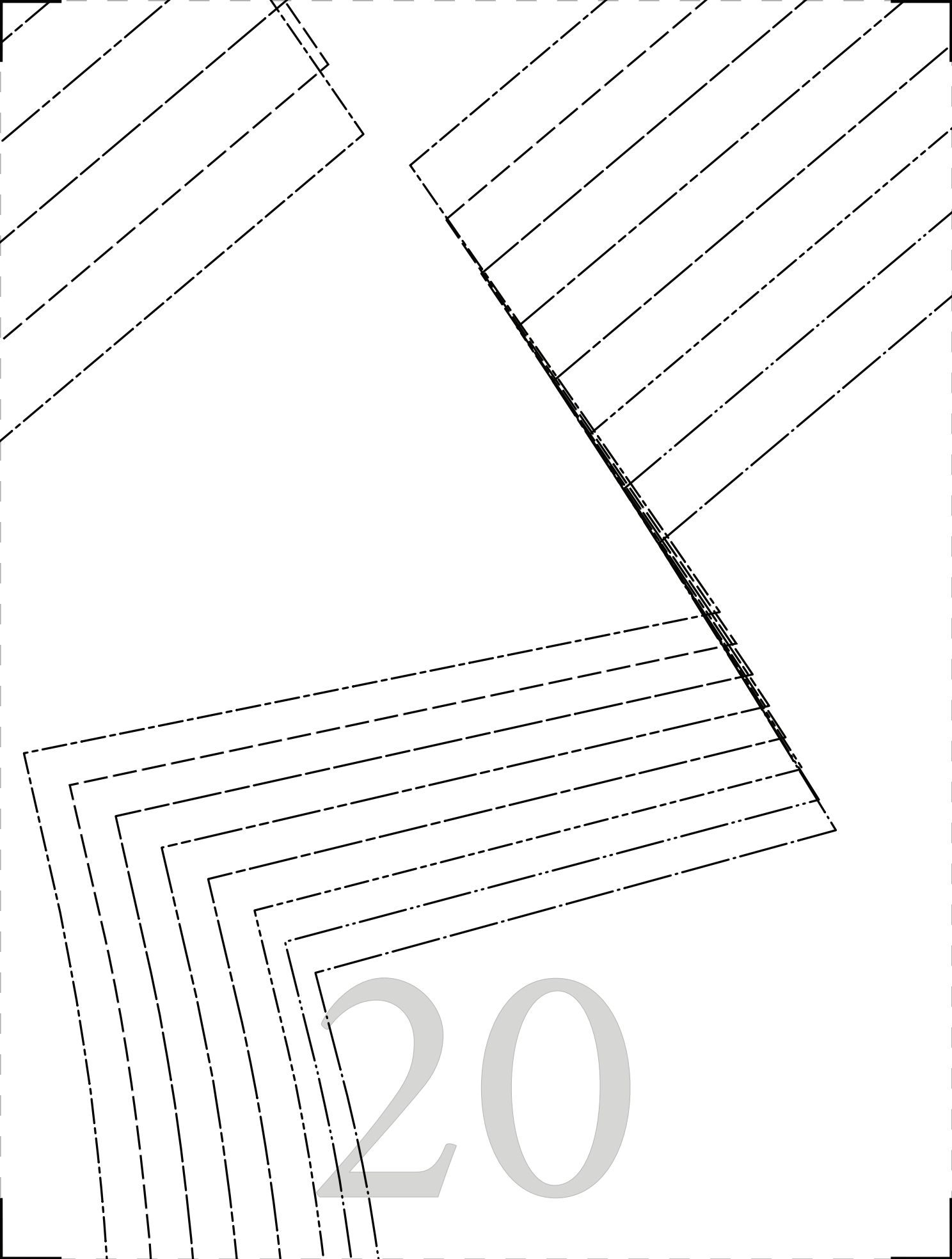

20

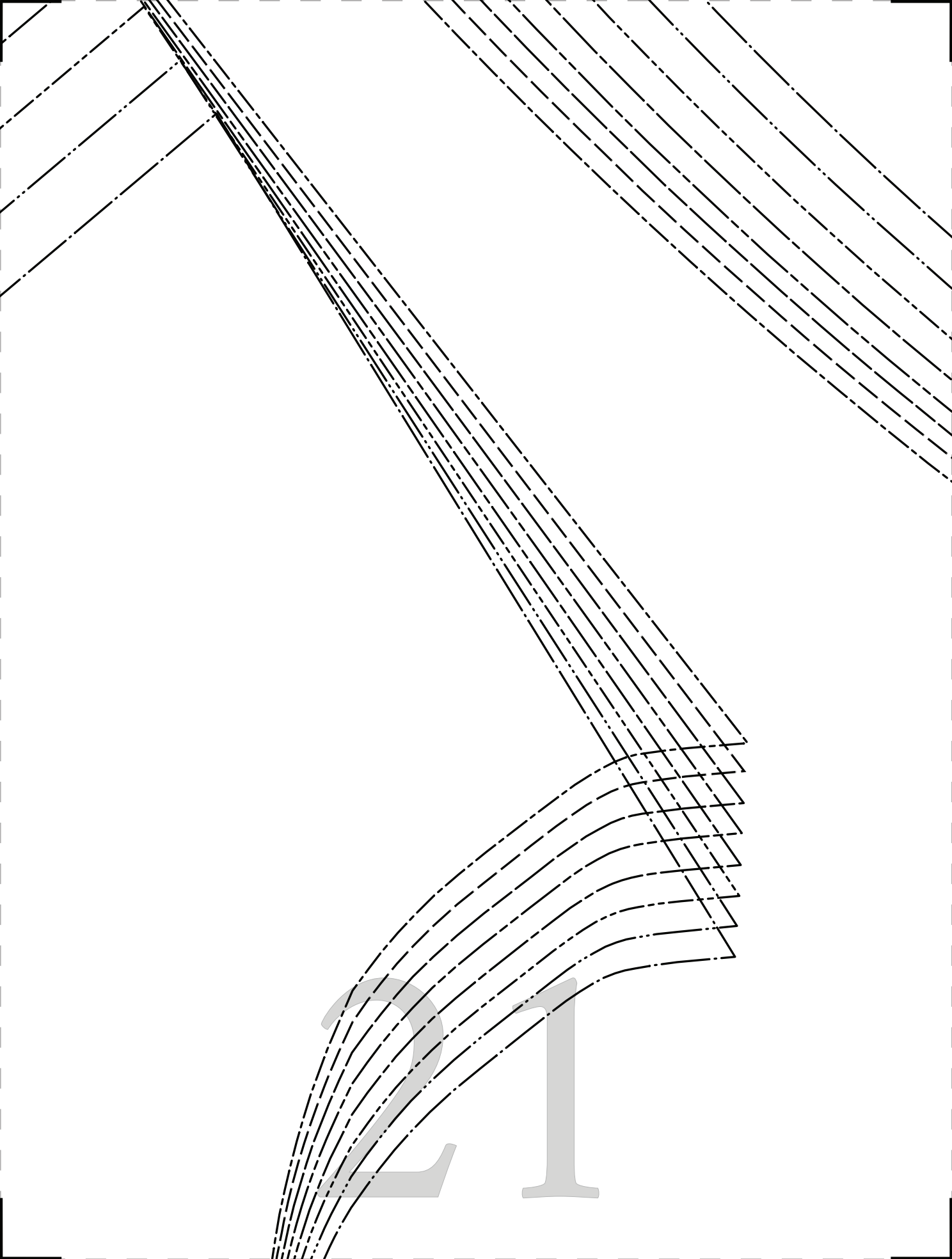

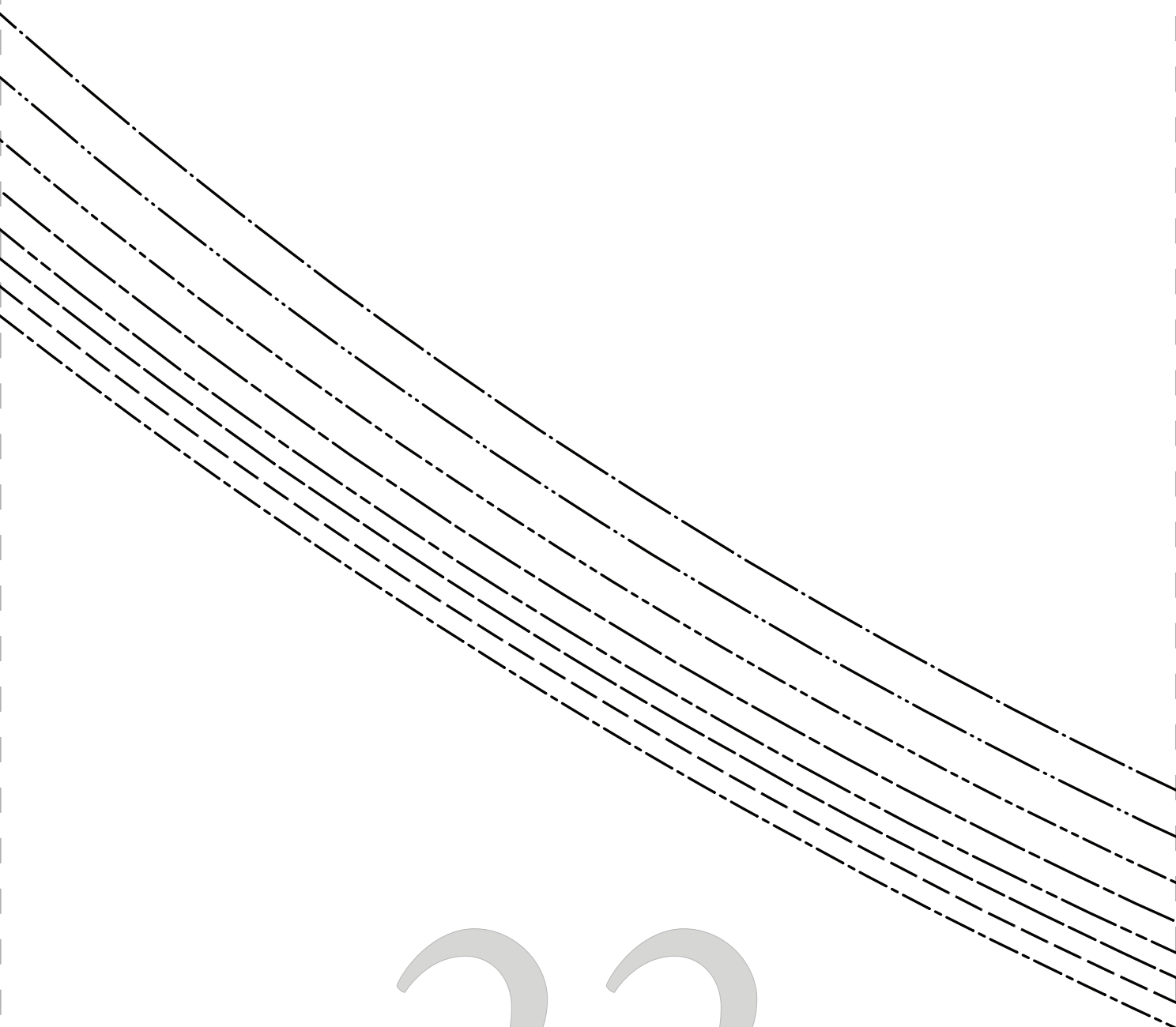

22

23



24



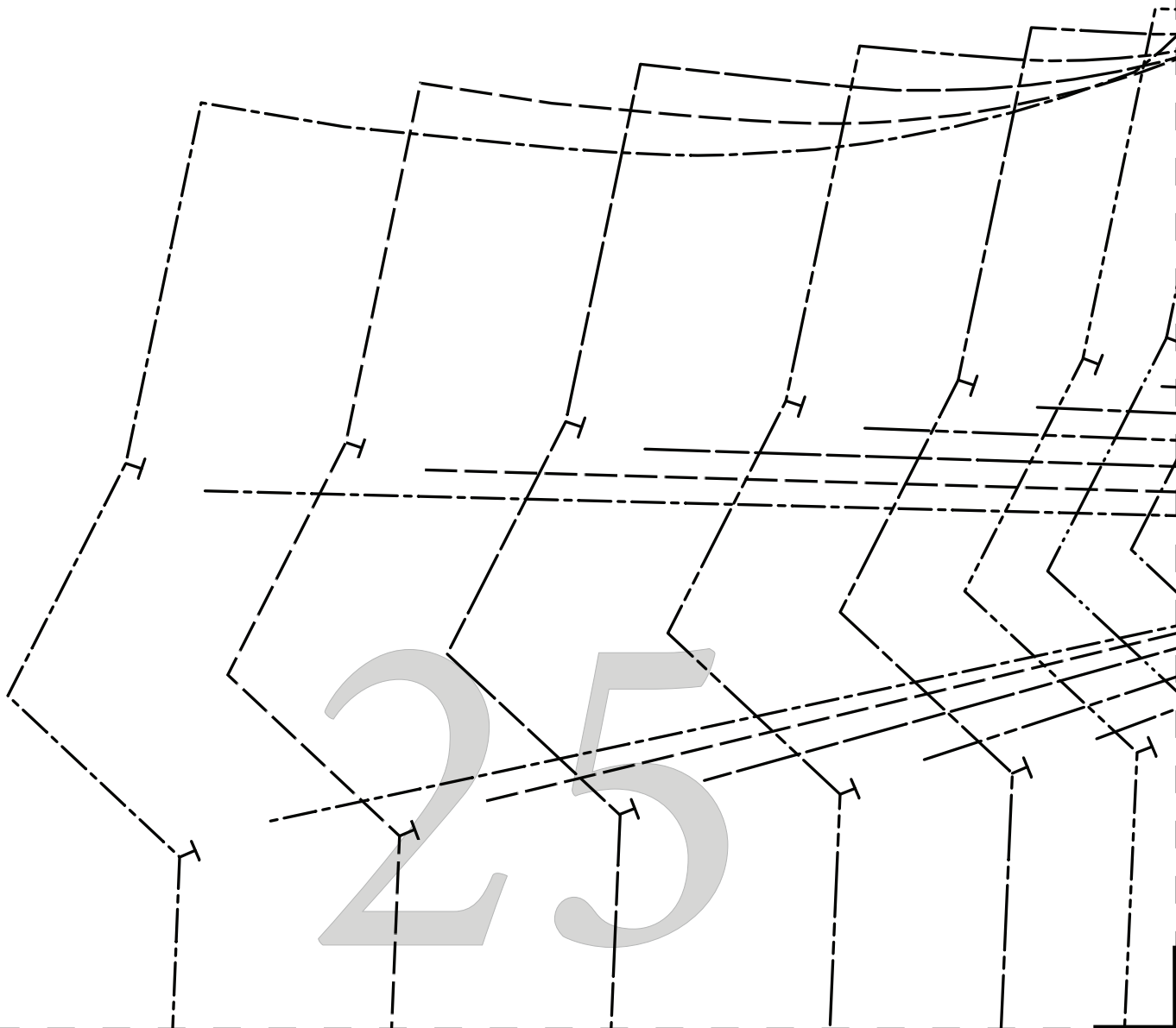

25

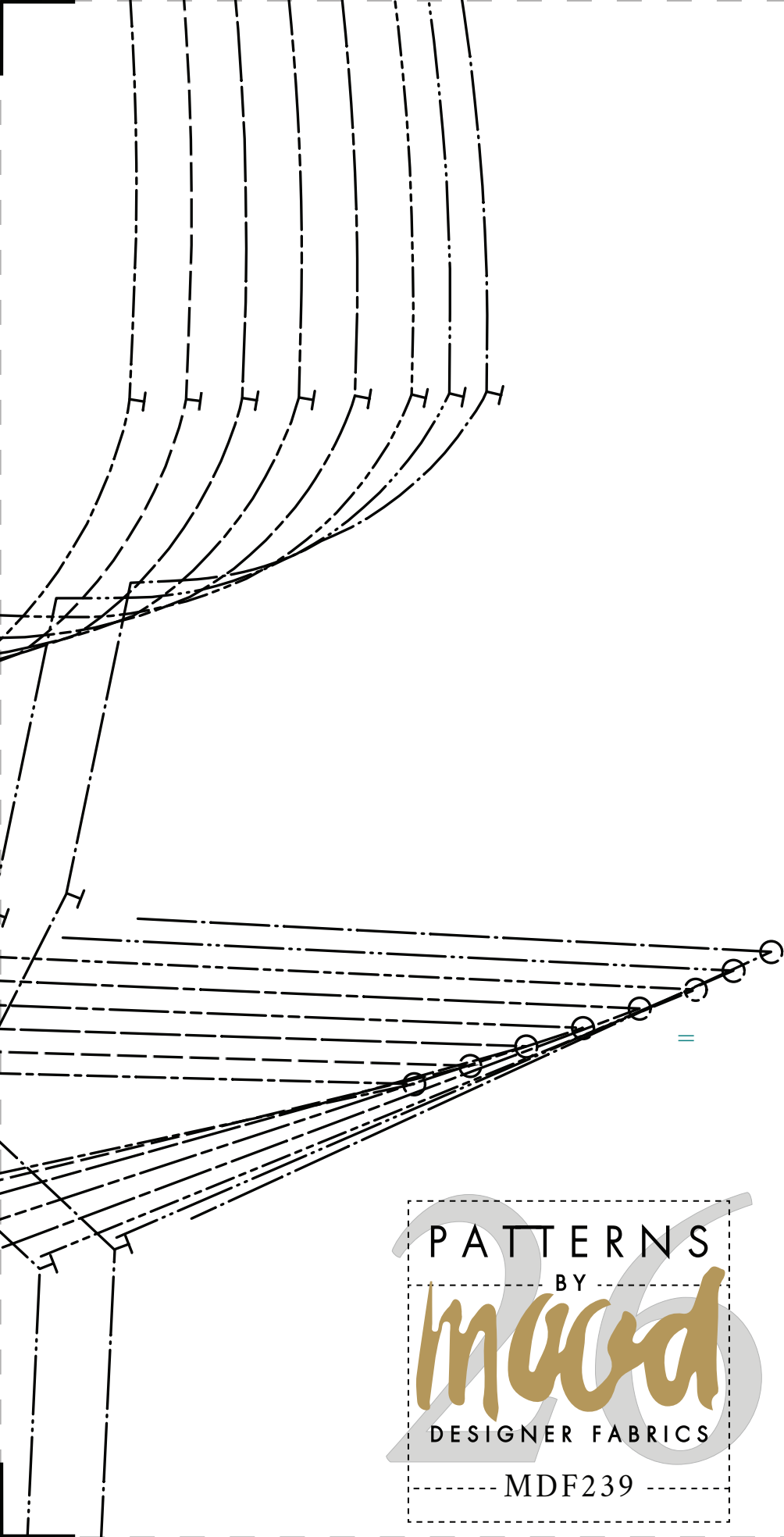

PATTERNS
BY
maeva
DESIGNER FABRICS
MDF239

↑
RAINLINE

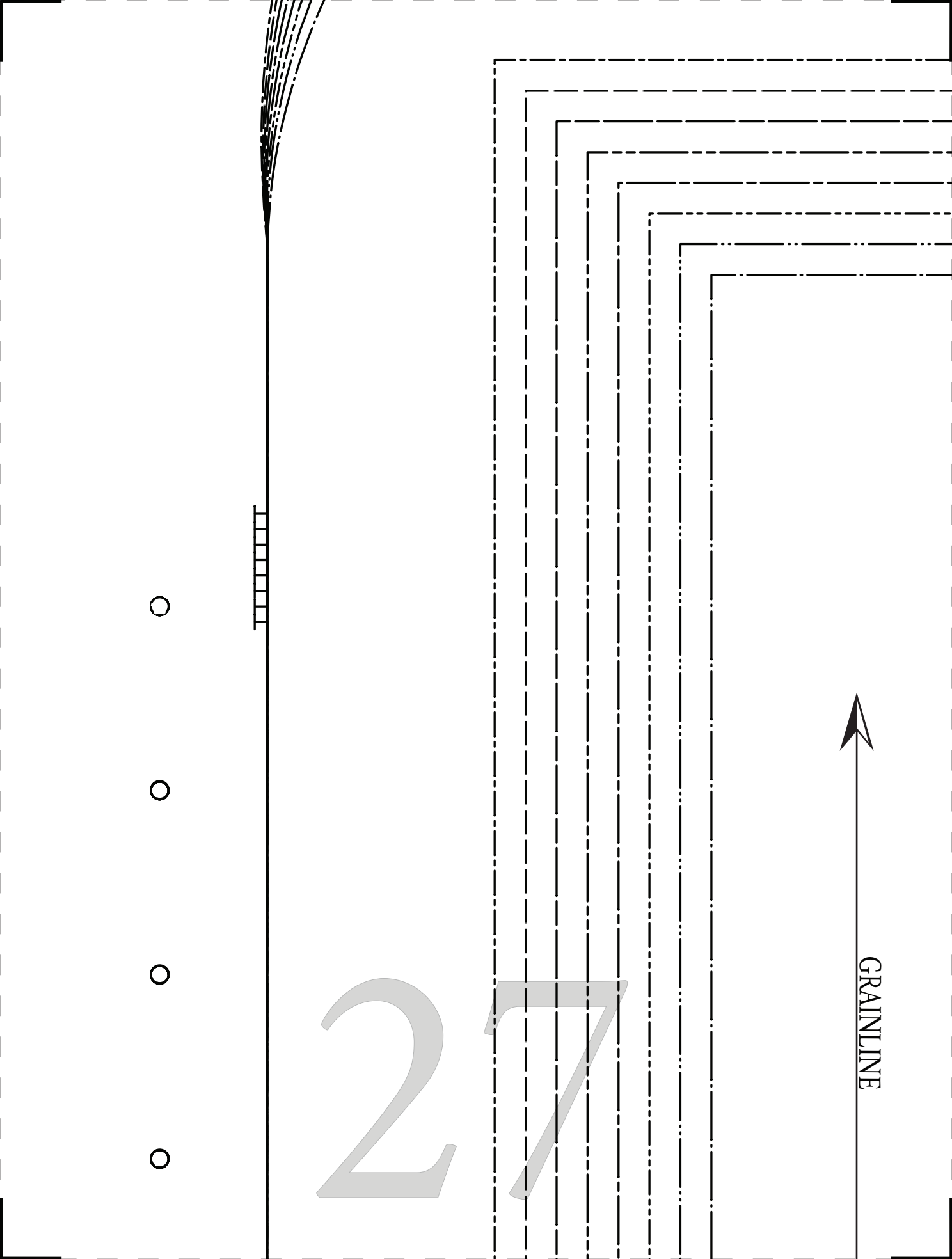

-
-
-
-
-



27



GRAINLINE

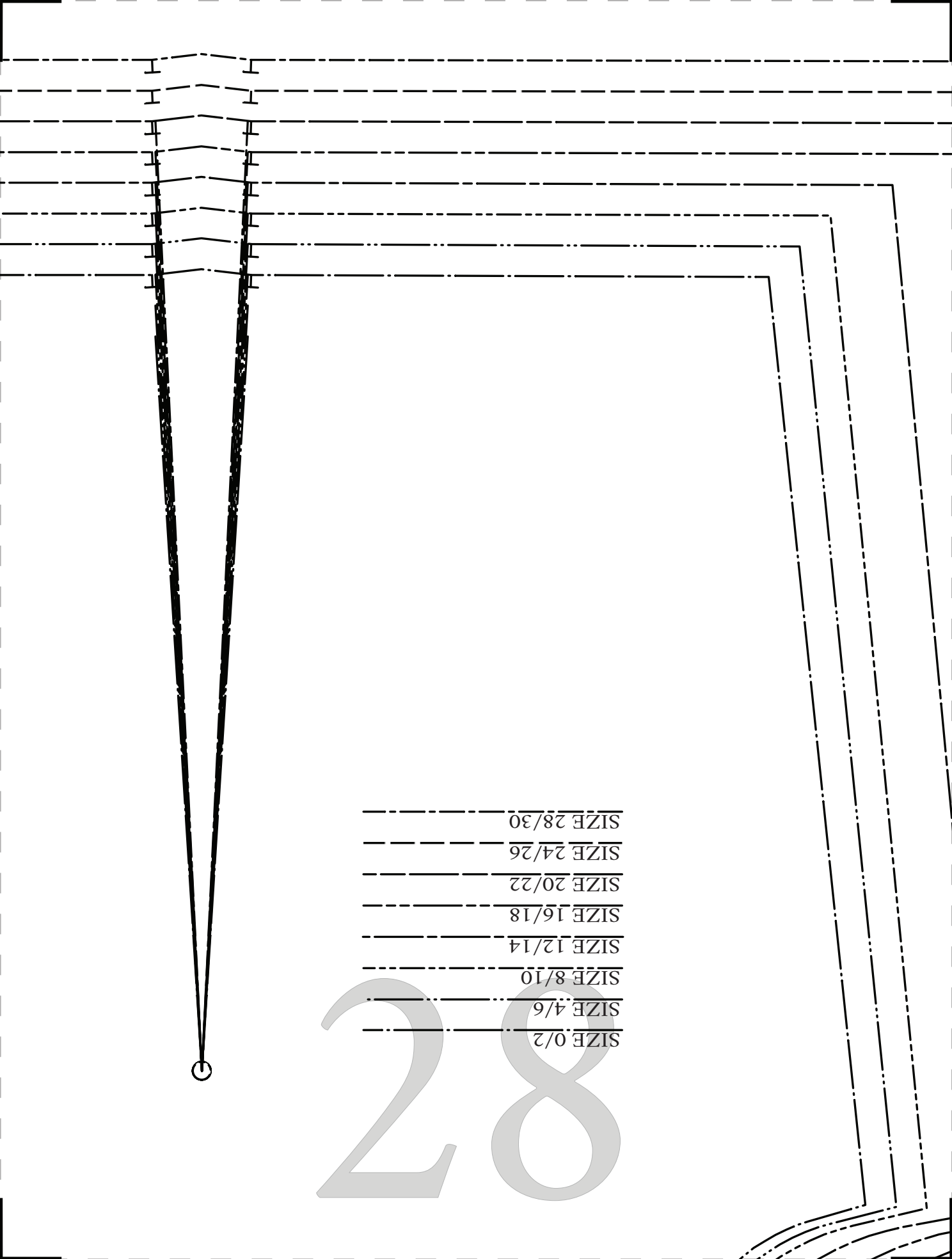

- SIZE 28/30
- SIZE 24/26
- SIZE 20/22
- SIZE 16/18
- SIZE 12/14
- SIZE 8/10
- SIZE 4/6
- SIZE 0/2

28

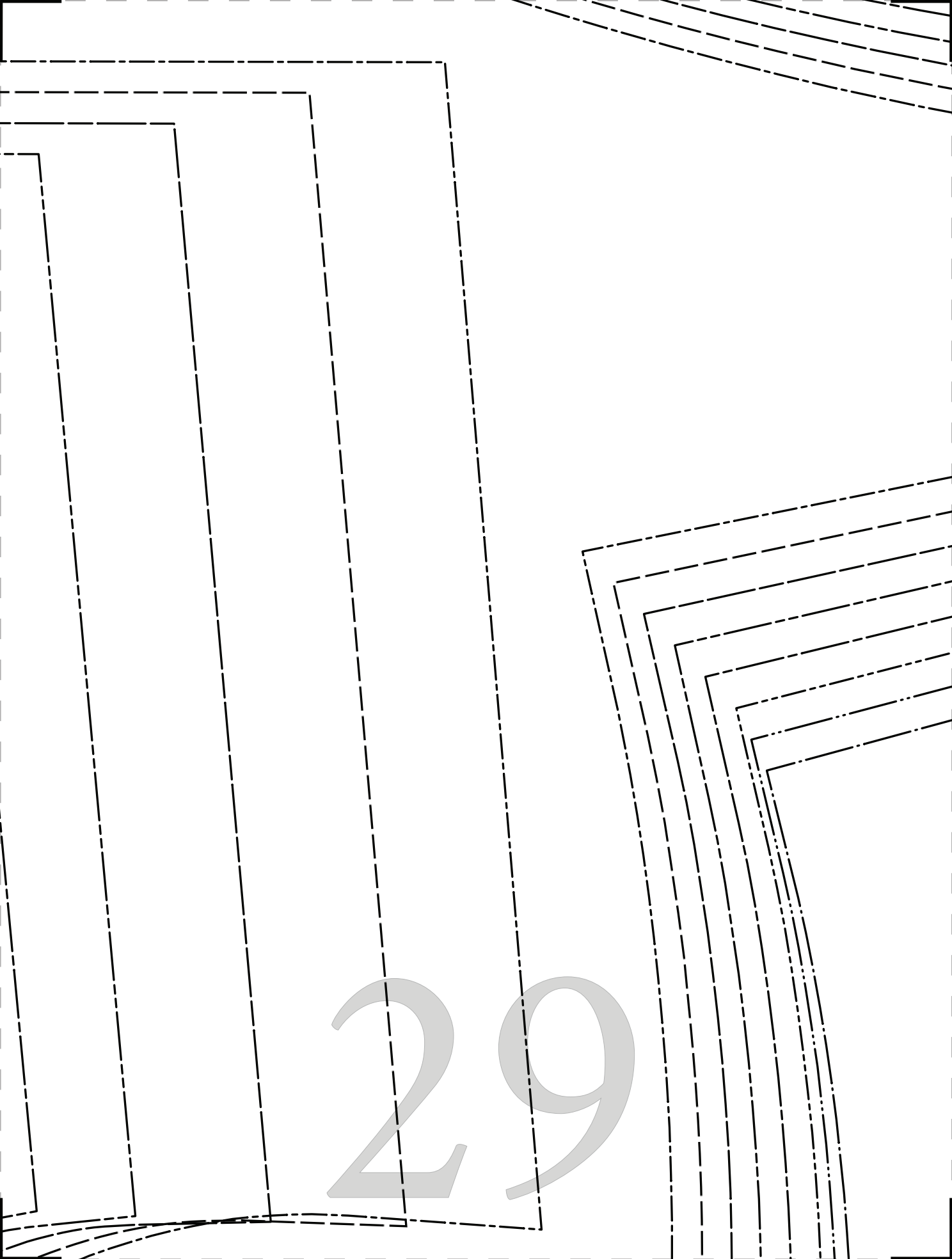

29

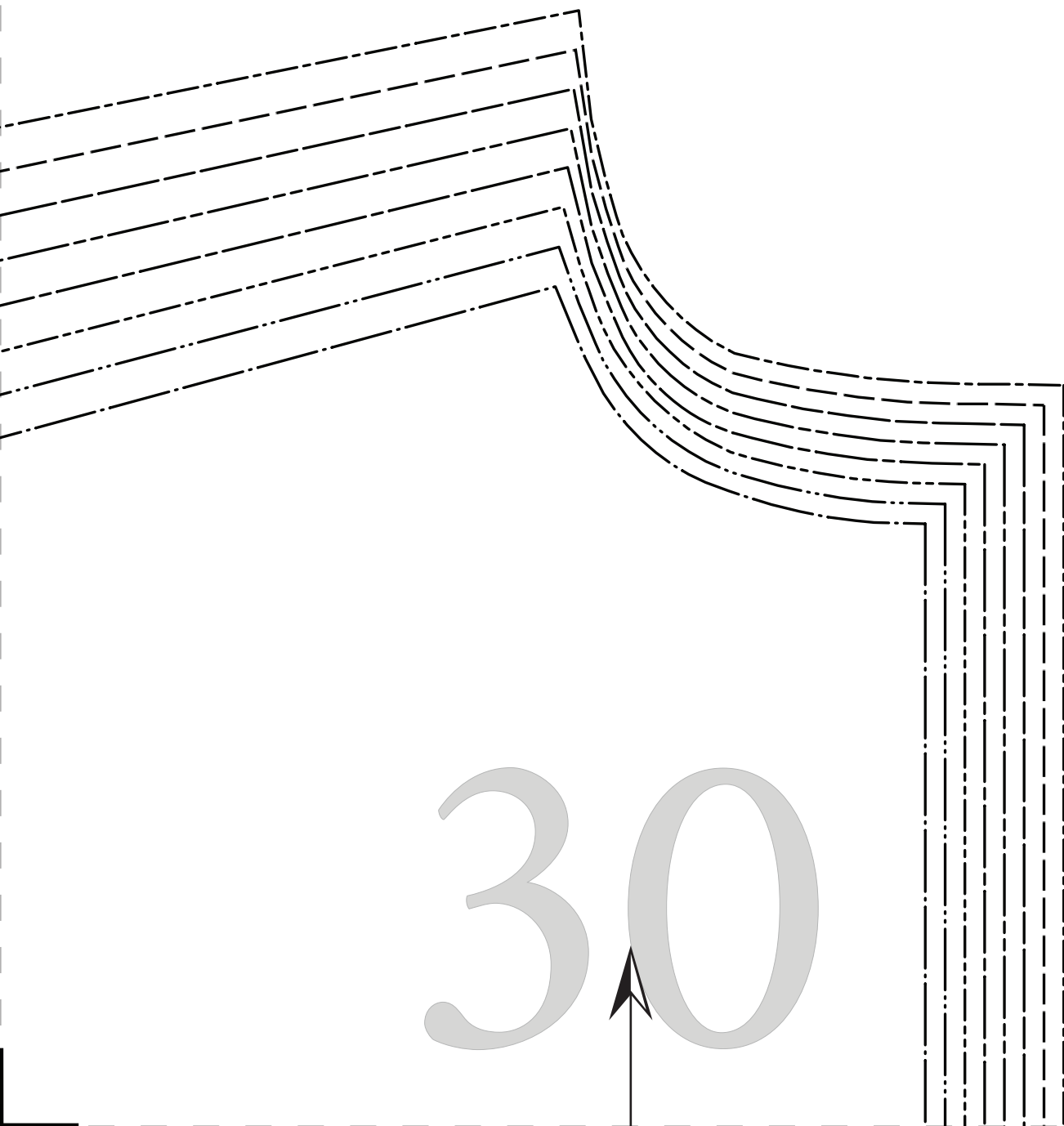
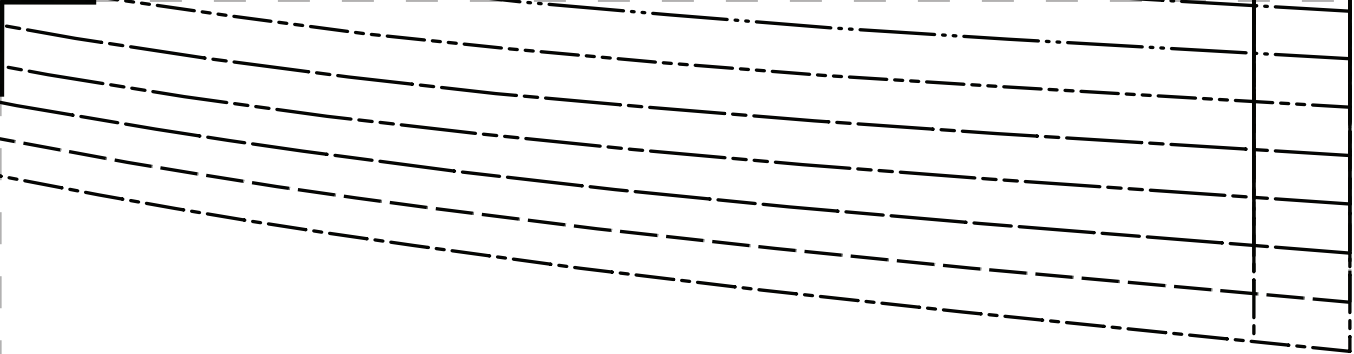

30



3 1

#MoodGambitPattern

“The Gambit Dress”
MDF023

SHIRT FRONT
CUT 2 OF FABRIC
FACE TO FACE

SIZE 0/2 _____

SIZE 4/6 _____

SIZE 8/10 _____

SIZE 12/14 _____

SIZE 16/18 _____

SIZE 20/22 _____

SIZE 24/26 _____

SIZE 28/30 _____

32

Handwriting practice area with a vertical line on the left and a horizontal line at the bottom. The area contains four small circles arranged vertically and several horizontal lines, some solid and some dashed, for tracing.

3

3

Handwriting practice area with a vertical line on the left and a horizontal line at the bottom. The area contains several horizontal lines, some solid and some dashed, for tracing. An arrow points downwards from the top right corner.

DRESS BODICE BACK
CUT 2 OF FABRIC AND LINING
FACE TO FACE

“The Gambit Dress”
MDF023

#MoodGambitPattern



34



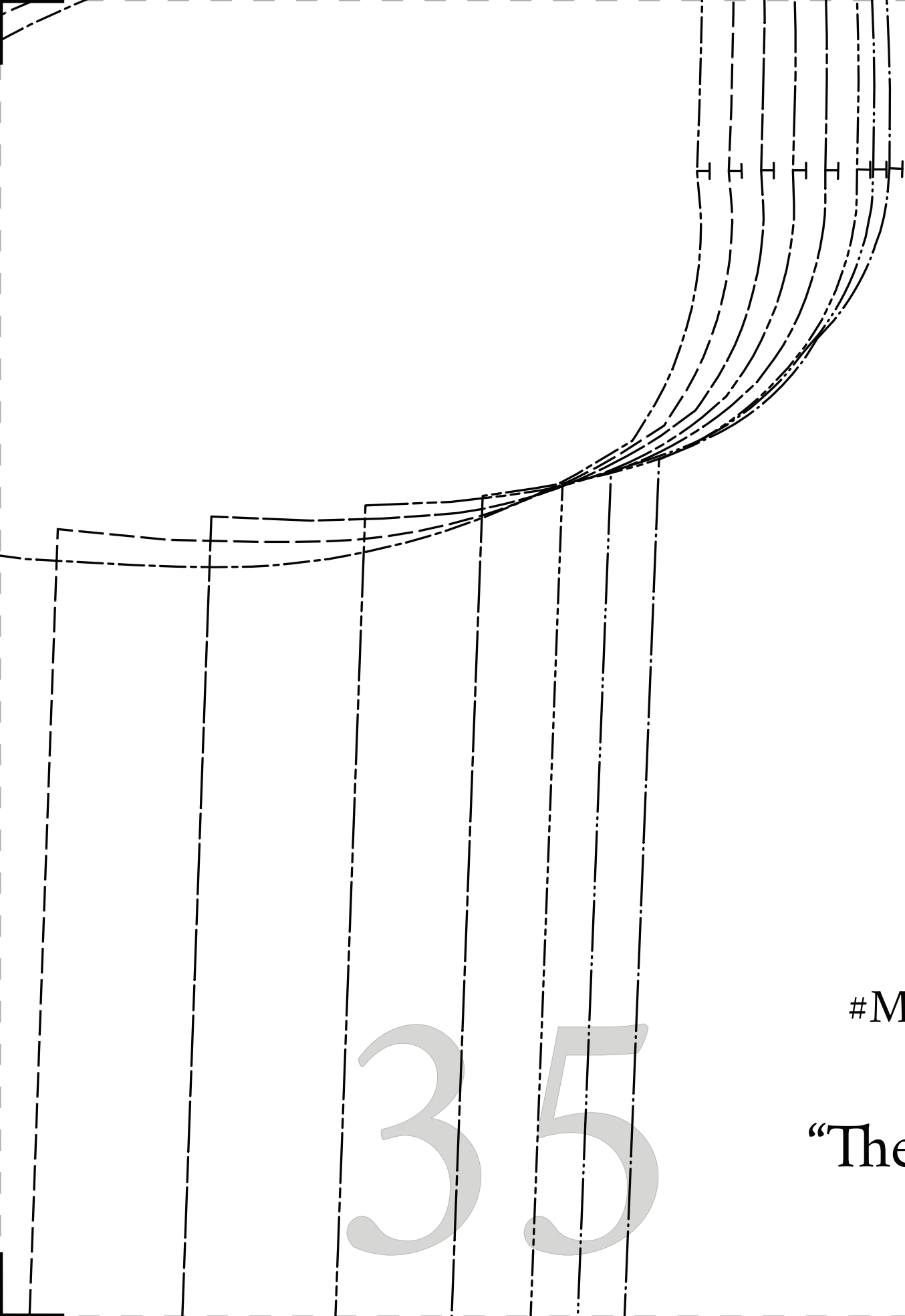

#MoodC

“The Ga
M

SH

35

PATTERNS
BY
wood
SIGNER FABRICS
MDF239

GambitPattern

Gambit Dress"
MDF023

PT BACK

GRAINLINE

36



PLACE ON FOLD OF FABRIC

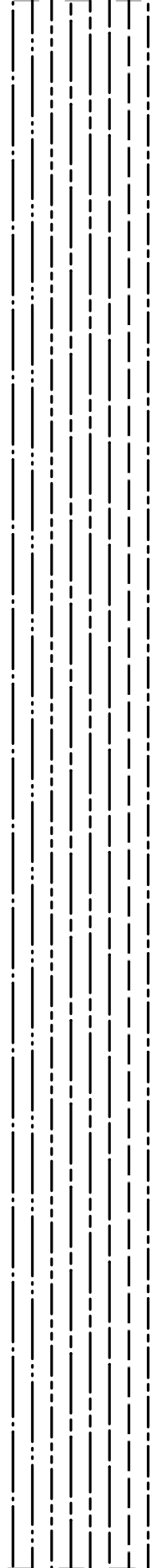

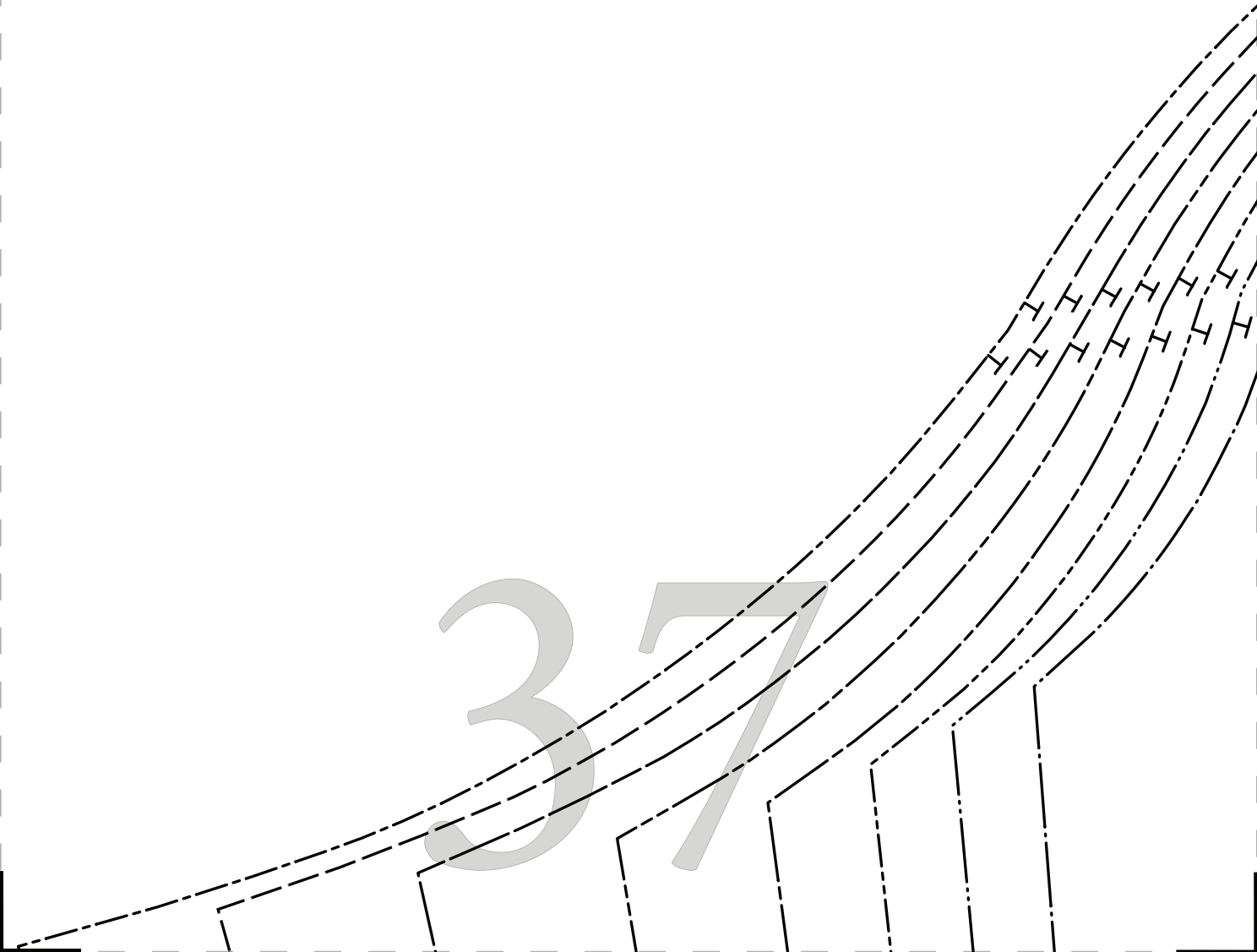

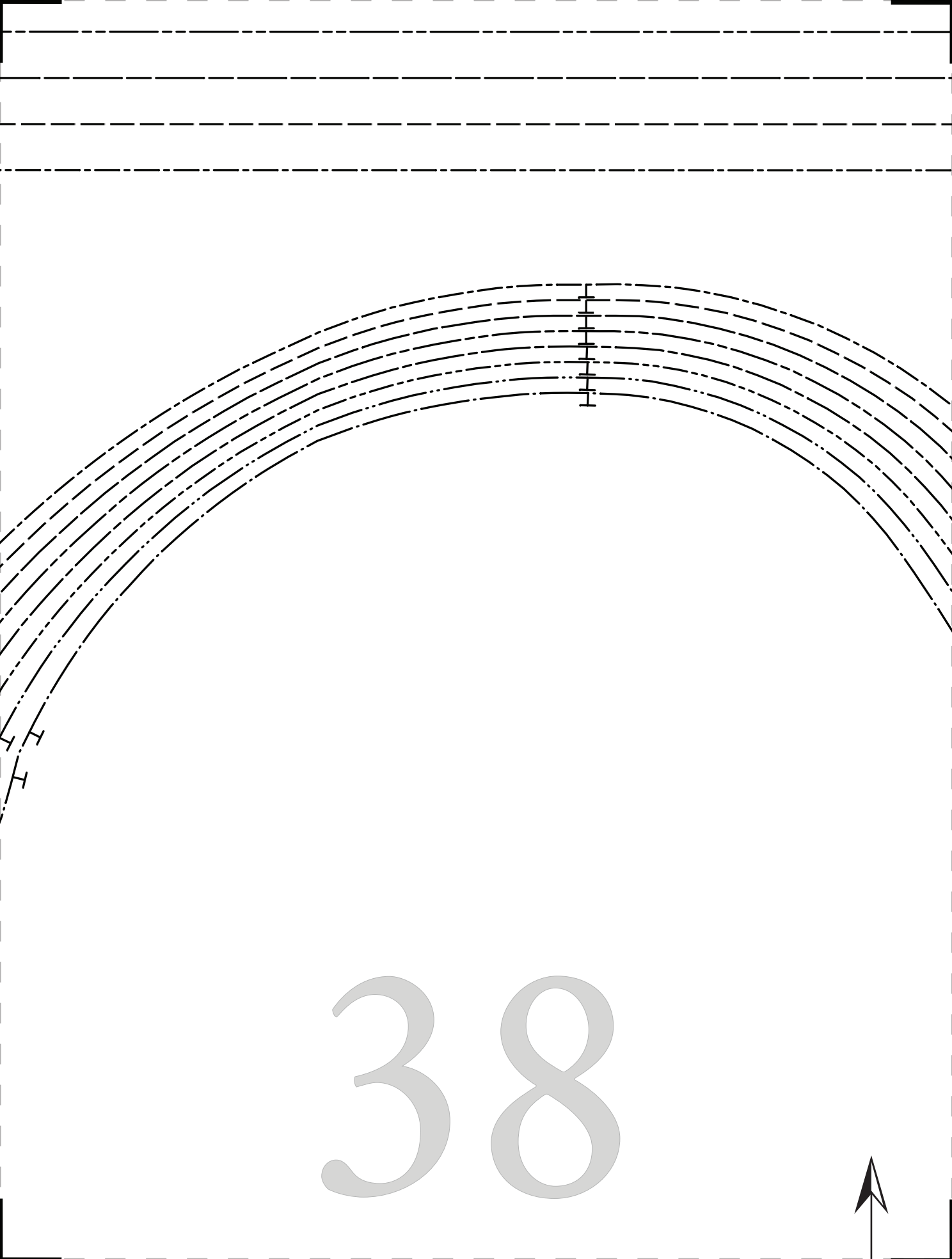

38



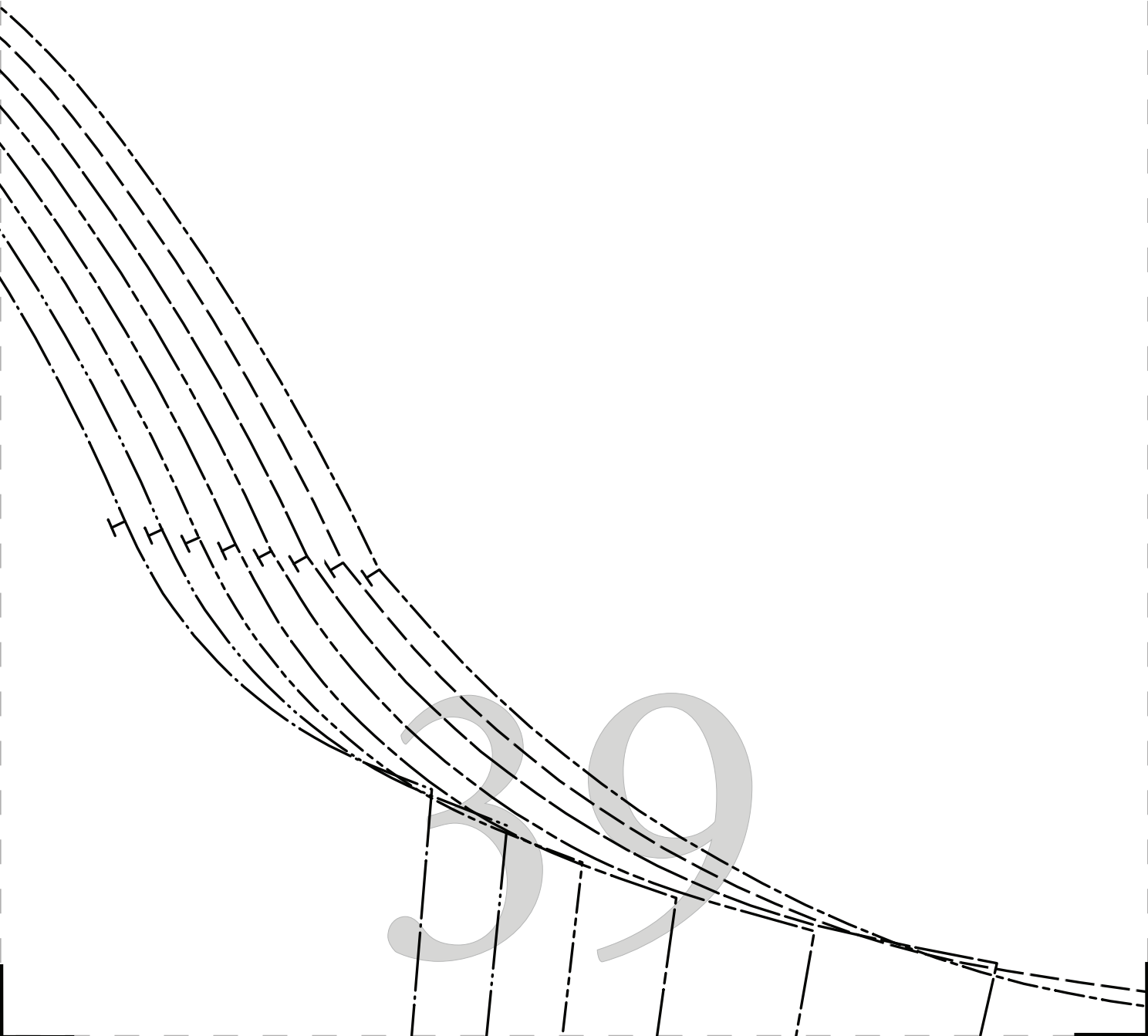
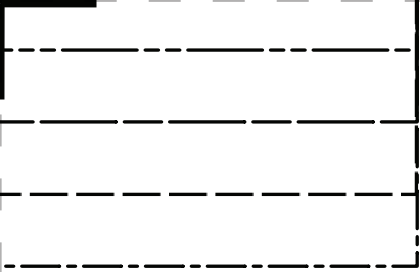



“The Gambit Dress”
MDF023

SLEEVE SLIT BINDING,
CUT 2 OF FABRIC ON BIAS

40

CUT 1 OF FA

- SIZE
- SIZE
- SIZE
- SIZE
- SIZE
- SIZE
- SIZE
- SIZE

41

RT BACK
BRIC ON THE FOLD

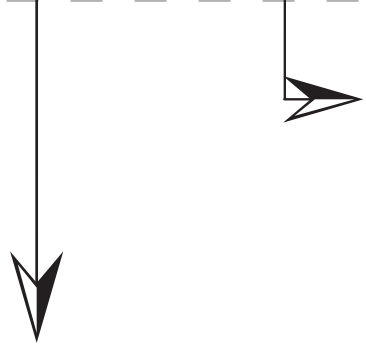

- 0/2
- 4/6
- 8/10
- 12/14
- 16/18
- 20/22
- 24/26
- 28/30

42

43



#MoodGambitPattern

“The Gambit Dress”
MDF023

SHIRT SLEEVE
CUT 2 OF FABRIC
FACE TO FACE

GRAINLINE

SIZE 0/2

SIZE 4/6

SIZE 8/10

SIZE 12/14

SIZE 16/18

SIZE 20/22

SIZE 24/26

SIZE 28/30

45

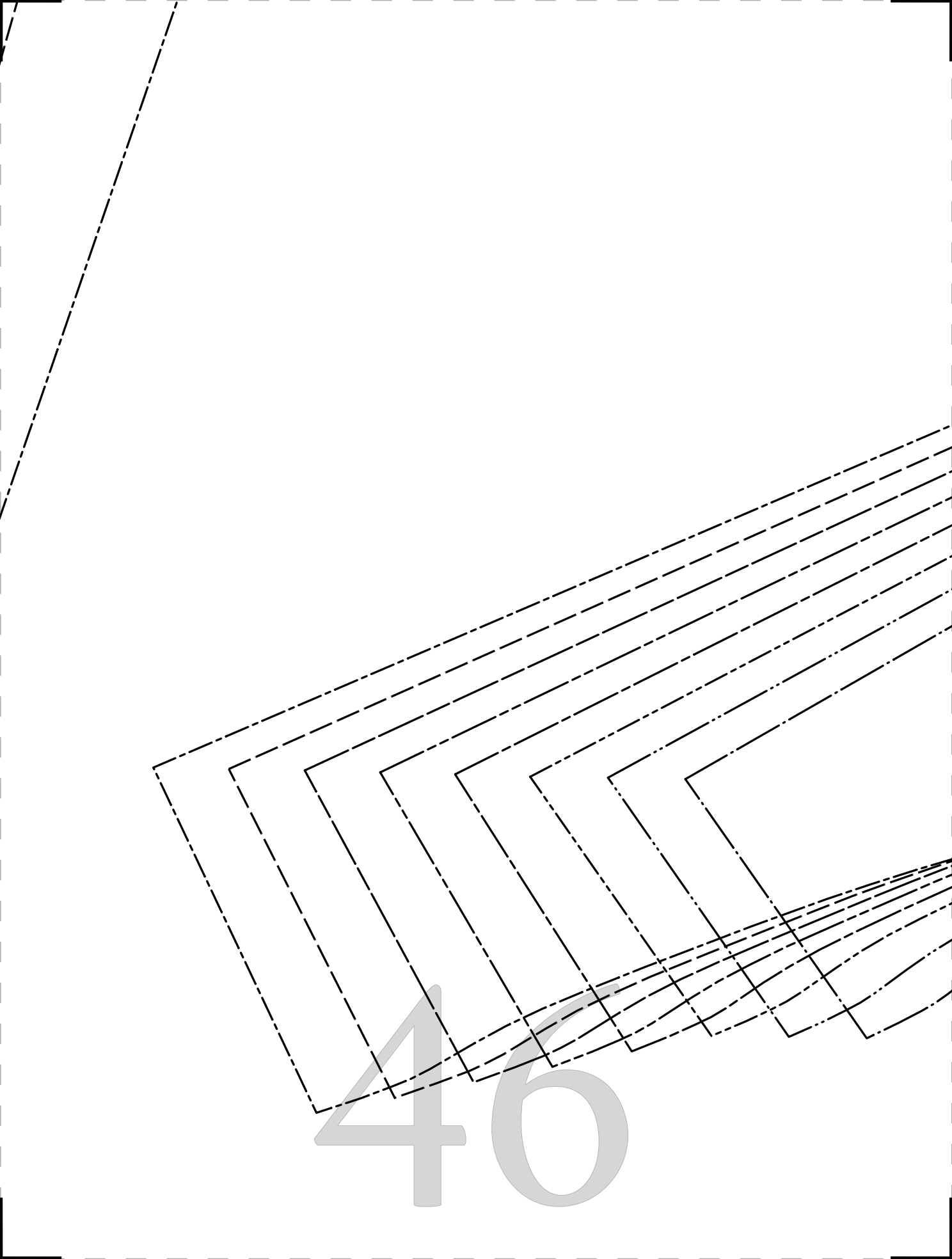

46

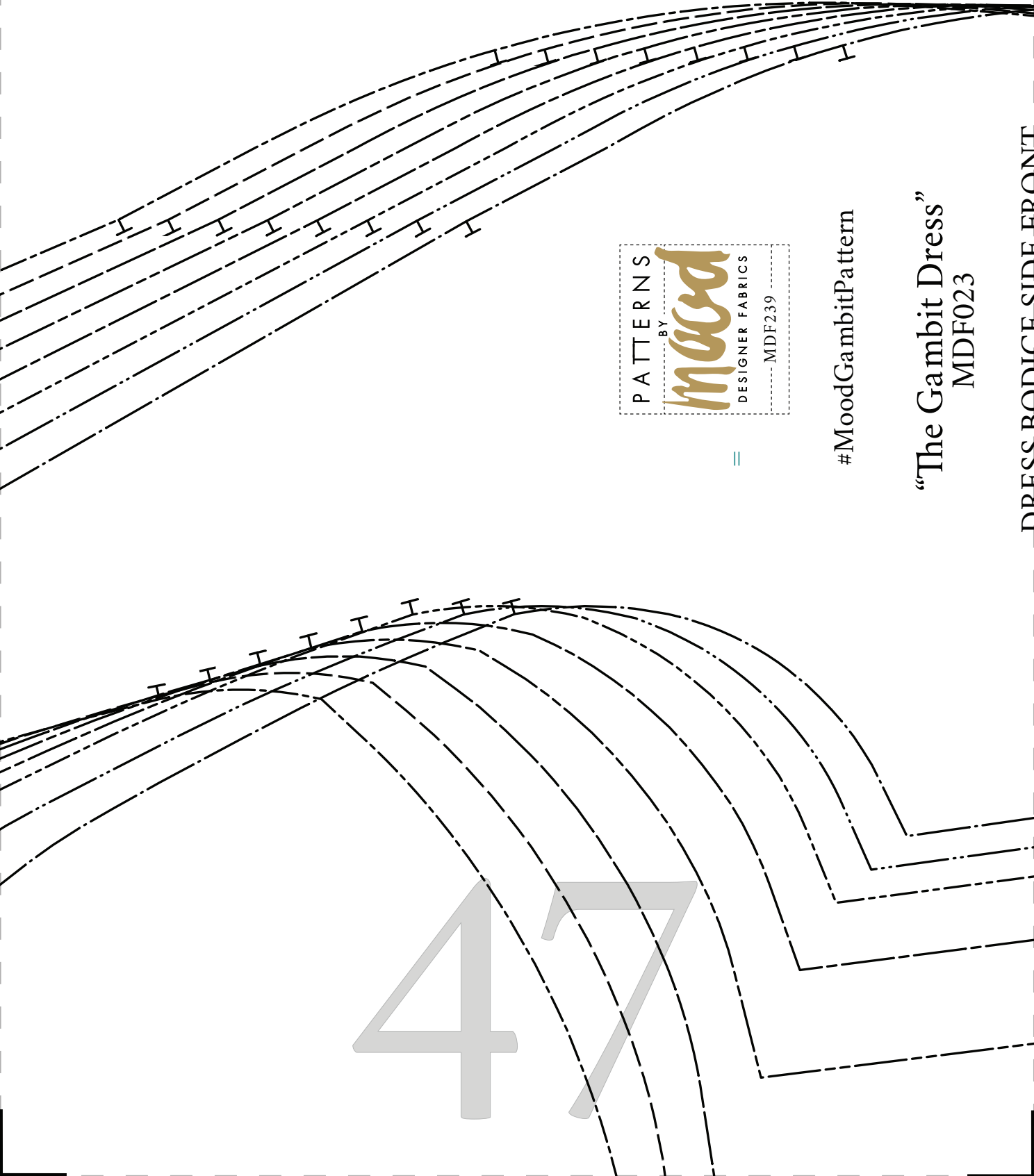

PATTERNS
BY
mood
DESIGNER FABRICS
MDF239



#MoodGambitPattern

“The Gambit Dress”
MDF023

DRESS BODICE SIDE FRONT

DRESS BODICE SIDE FRONT 1

CUT 2 OF FABRIC AND LINING
FACE TO FACE

- SIZE 0/2
- SIZE 4/6
- SIZE 8/10
- SIZE 12/14
- SIZE 16/18
- SIZE 20/22
- SIZE 24/26
- SIZE 28/30

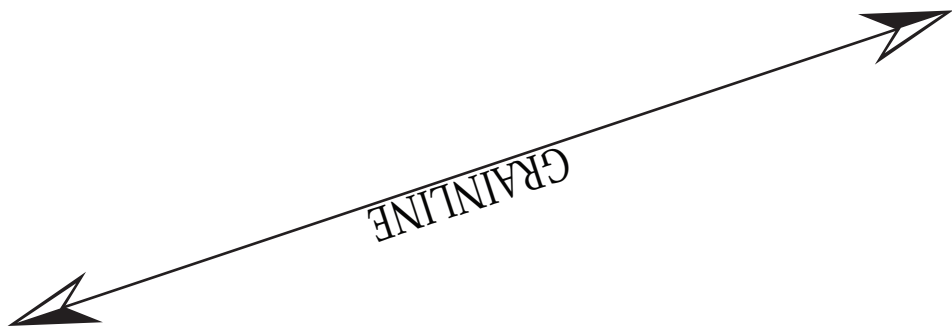

48

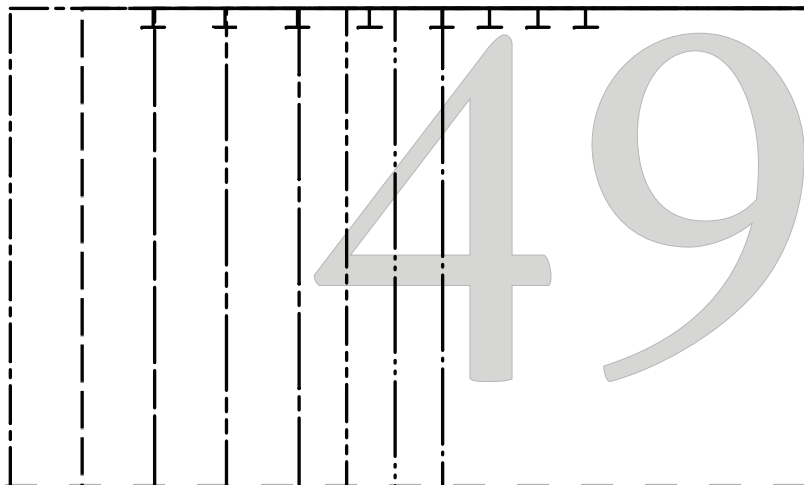
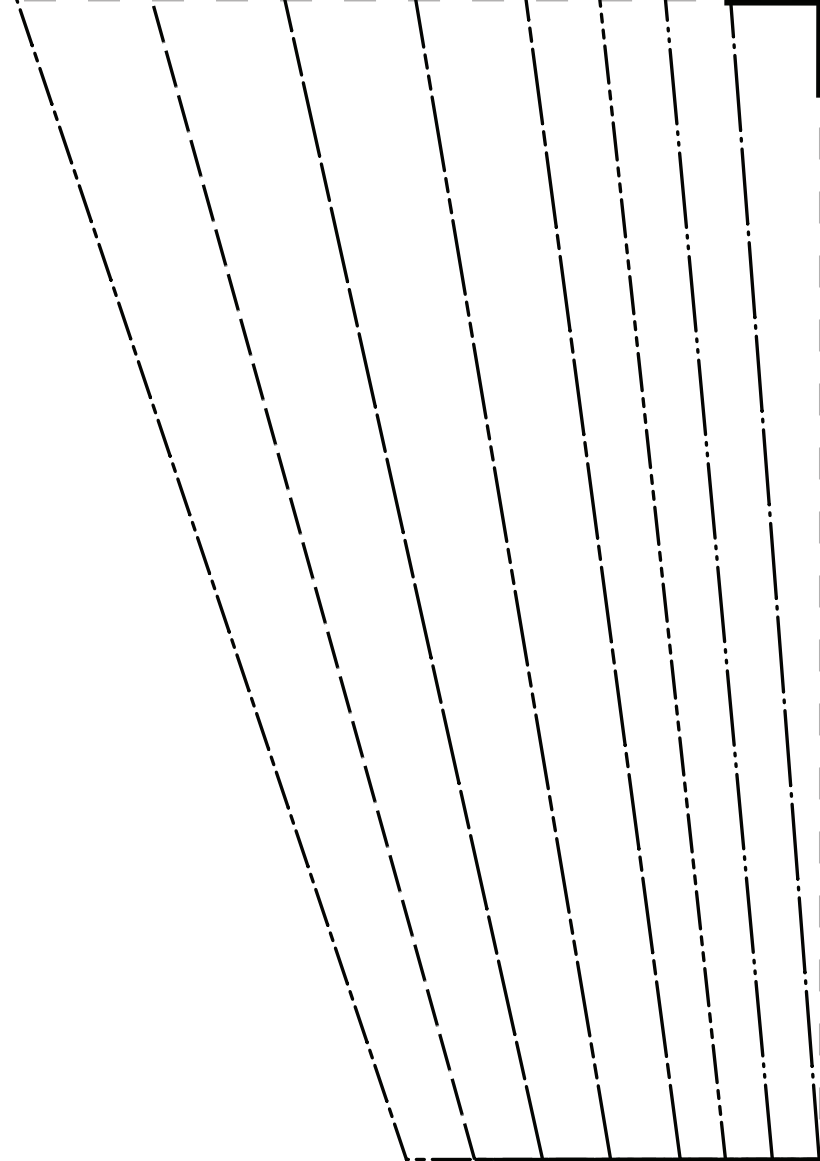

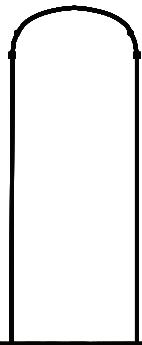

50

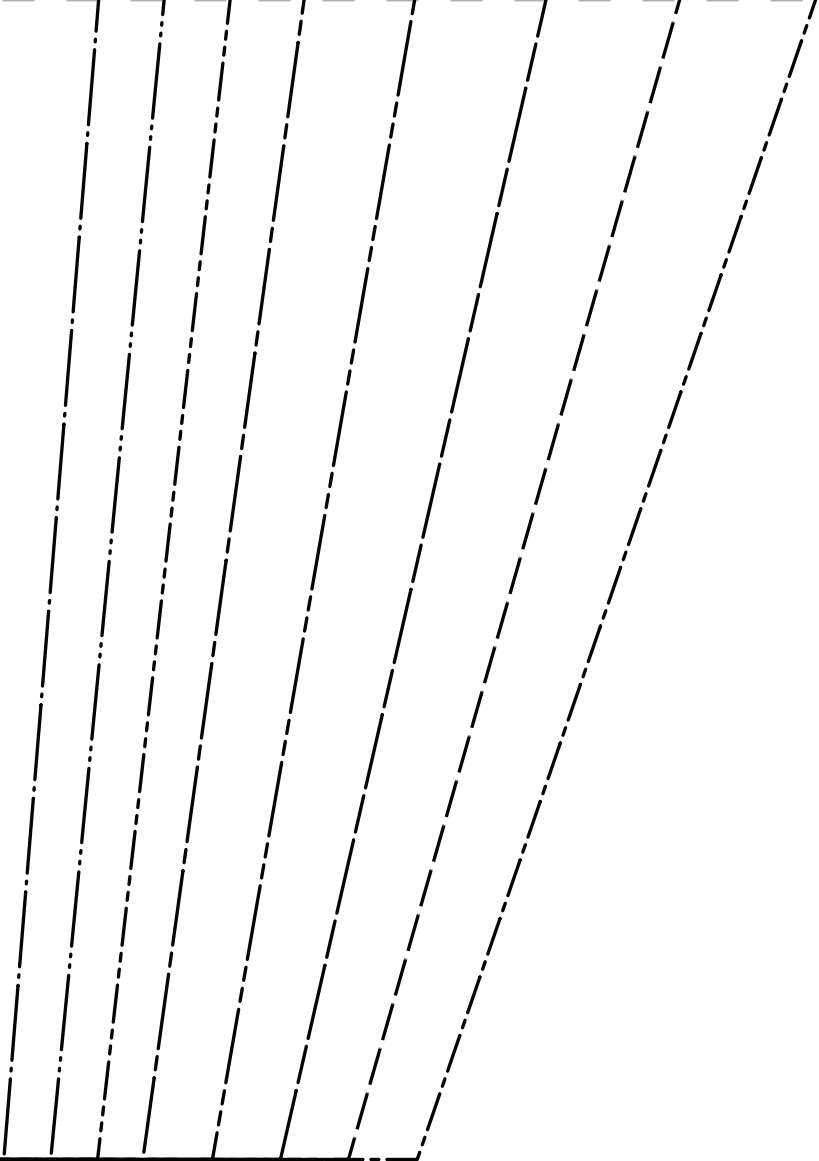

51

DRESS BODICE
CUT 4
(TWO-PAIR)

52

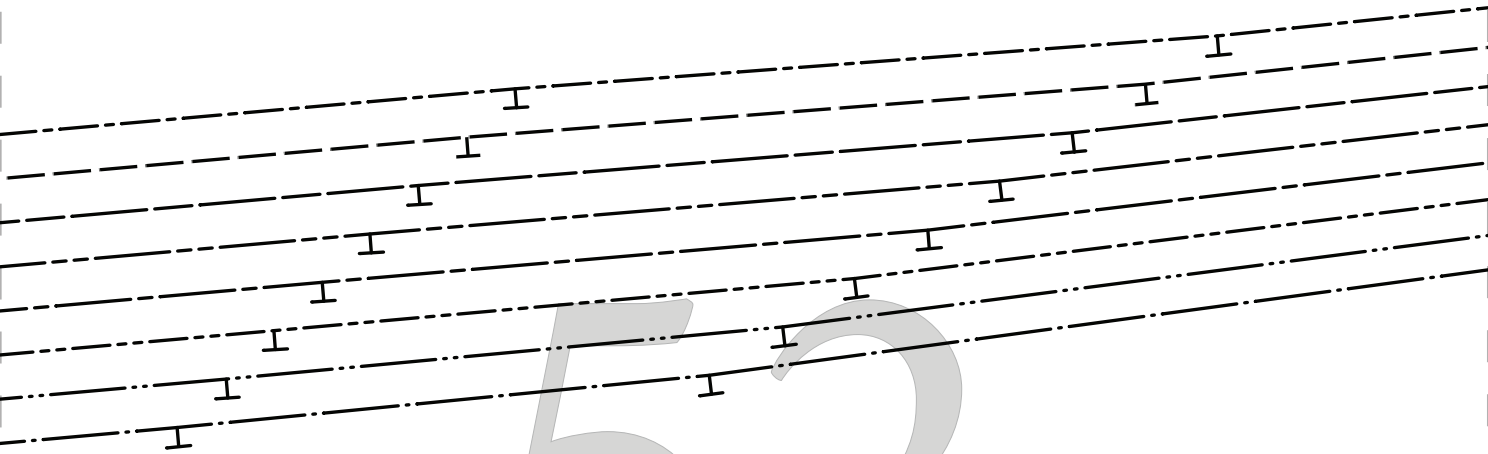

#Moody

“The Ga
M

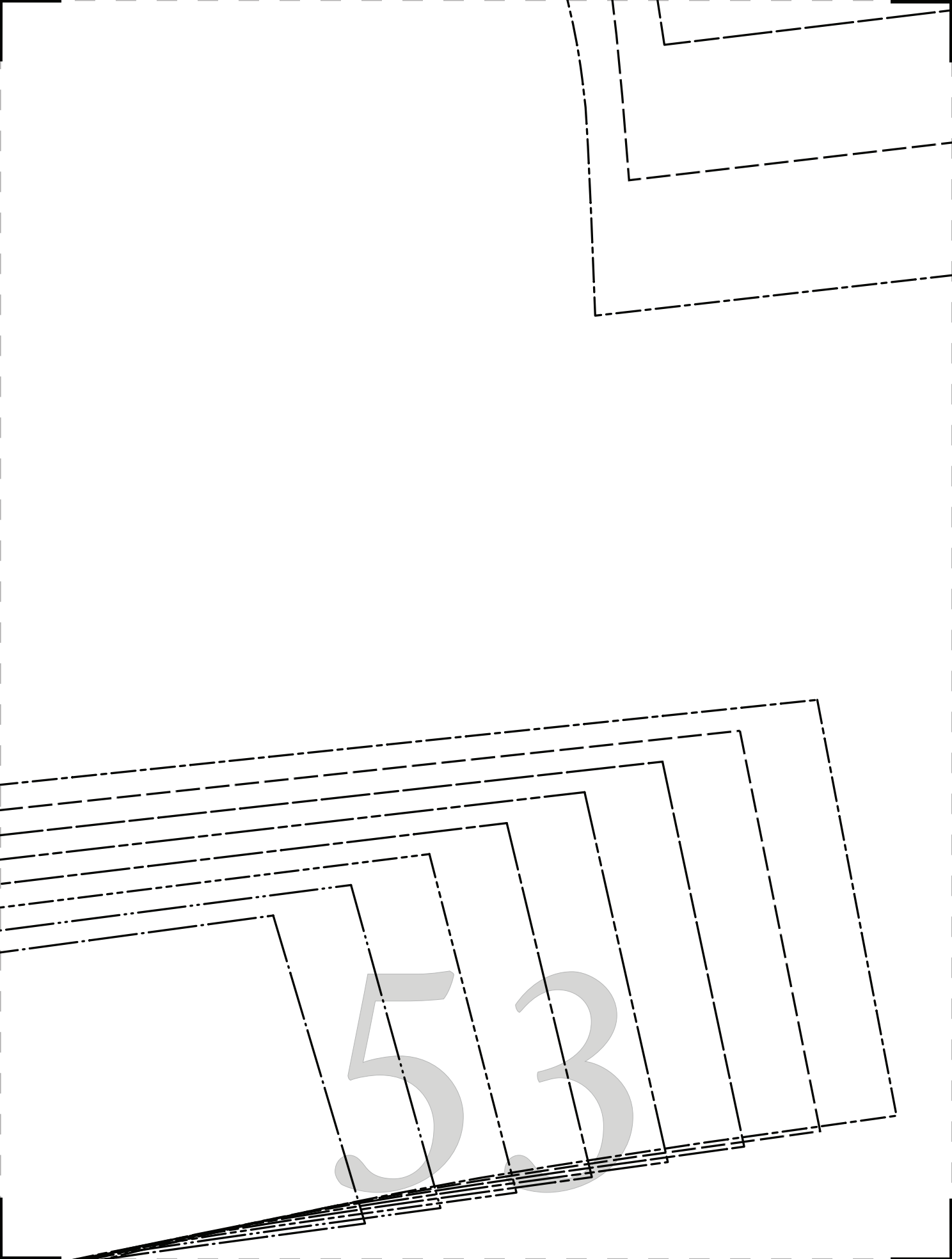

53

54

#MoodGambitPattern

“The Gambit Dress”
MDF023

SLEEVE CUFF, CUT 2 OF FABRIC
(OPTIONAL: CUT 2 OF INTERFACING)

- SIZE 0/2
- SIZE 4/6
- SIZE 8/10
- SIZE 12/14
- SIZE 16/18
- SIZE 20/22
- SIZE 24/26
- SIZE 28/30

55

CE
(NG)

GRAINLINE



56

THE CENTER FRONT
OF FABRIC
(FACE TO FACE)

GRAINLINE

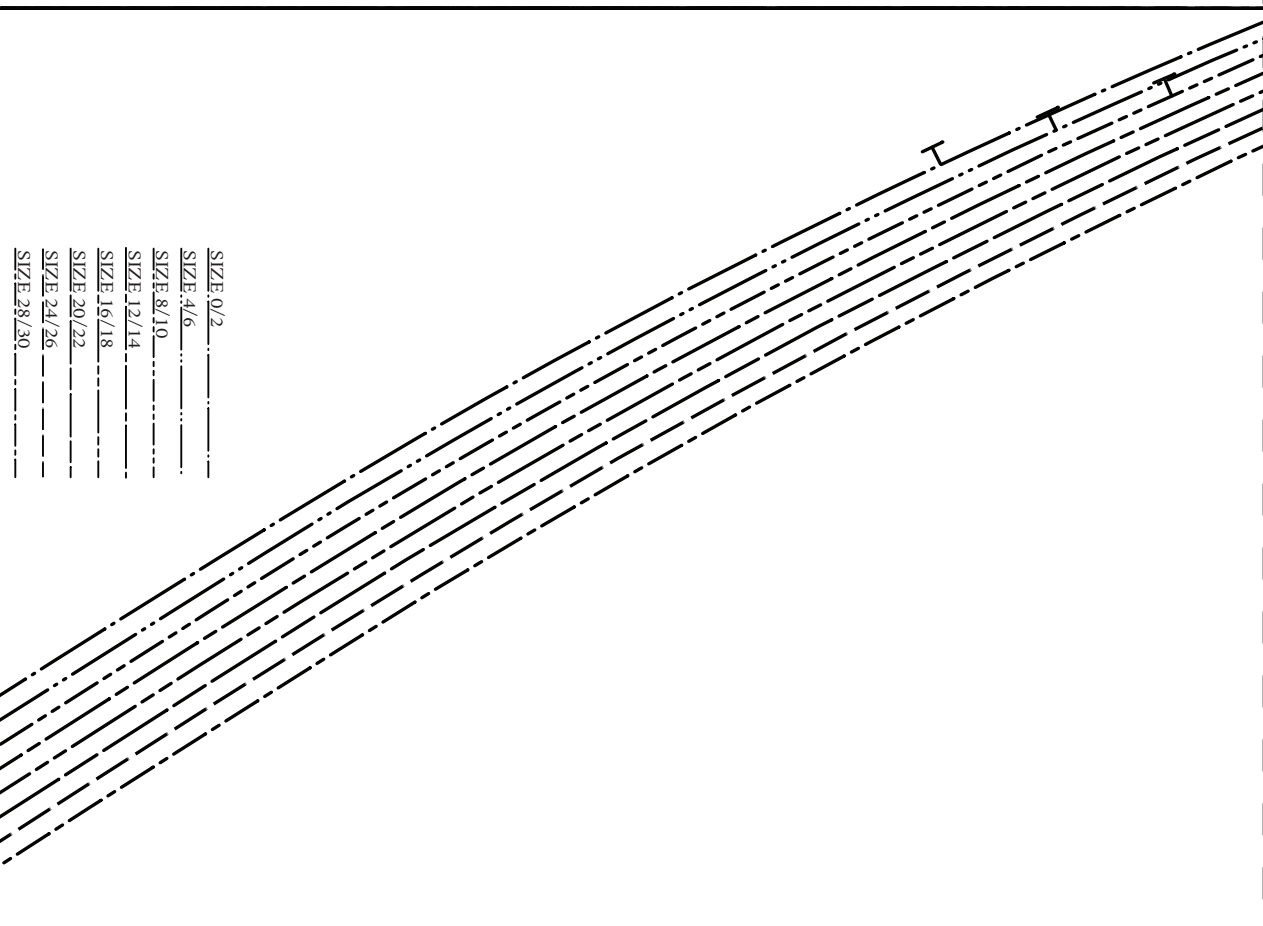

- SIZE 0/2
- SIZE 4/6
- SIZE 8/10
- SIZE 12/14
- SIZE 16/18
- SIZE 20/22
- SIZE 24/26
- SIZE 28/30

57

TT E R N S
BY
Wood
GENERAL FABRICS
MDF239

CamibitPattern

Camibit Dress”
IDF023

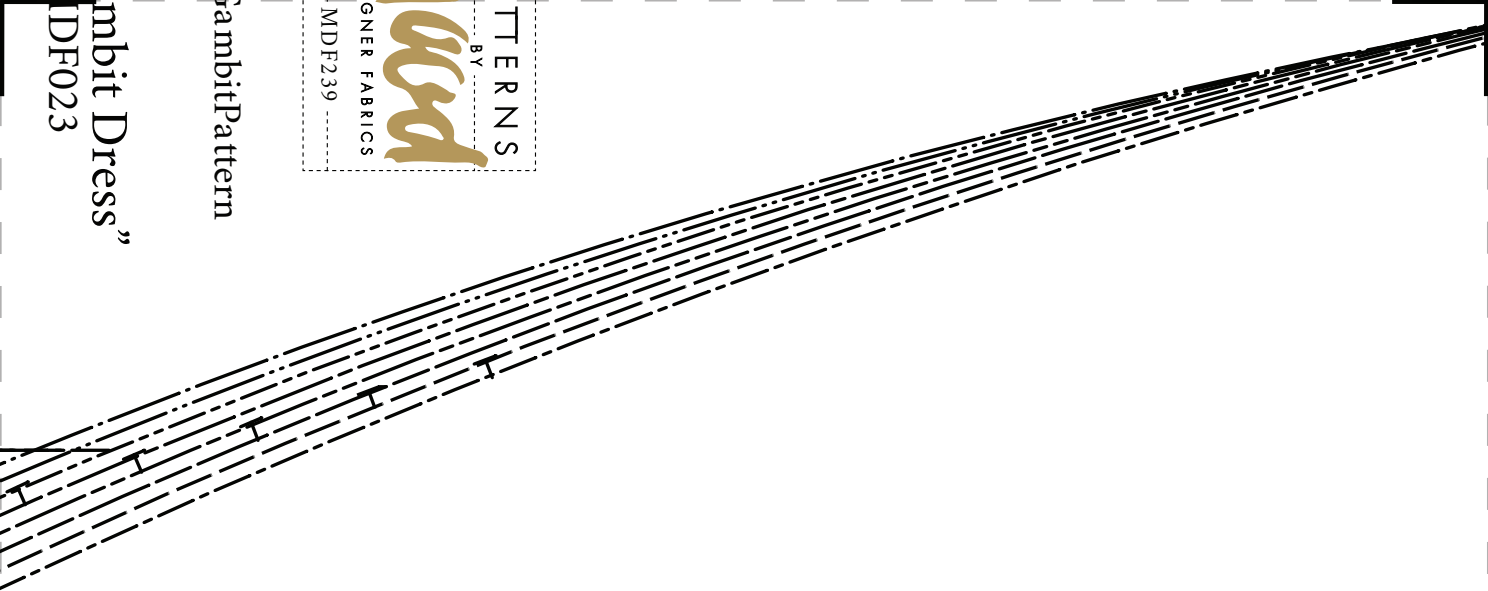

SIZE 0/2
SIZE 4/6
SIZE 8/10
SIZE 12/14
SIZE 16/18
SIZE 20/22
SIZE 24/26
SIZE 28/30

58



#MoodGambitPattern

“The Gambit Dress”
MDF023

SHIRT BUTTON PLACKET
CUT 2 OF FABRIC ON FOLD
(OPTIONAL: CUT 2 OF INTERFACING)

59

PLACE ON FOLD OF FABRIC

60