

# Service Manual

INTEGRATED AUDIO SYSTEM  
CUSTOM-MADE FOR HONDA

## RM-1500A

Area
[M] .....For U.S.A.

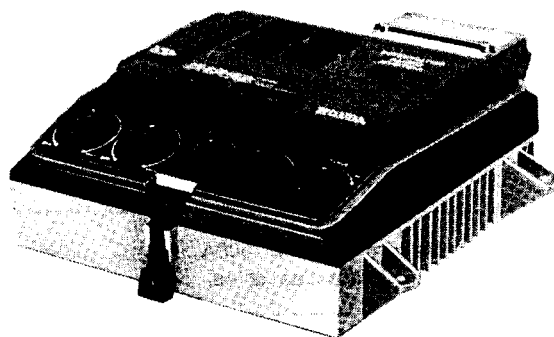

### RM-1500A MECHANISM SERIES

#### ■ SPECIFICATIONS

**General:**

Power Source: DC;12V(Negative Ground only)

Test Voltage: DC;14V

Power Consumption: 8A at maximum power output  
(Memory back-up 1 mA)

Power Output: Head set: 1W (8Ω/ch)

Main amp: 24W (3Ω/ch)

Dimensions: 101.6"(W) × 34.4"(H) × 124"(D)

(258×87.5×315)mm

Weight: 5lb 7oz (2.56kg) without bracket

**FM Tuner Section:**

Frequency Range: FM;87.5~107.9MHz

Usable Sensitivity: 10dB(S/N 30dB)

Signal to Noise Ratio: 55dB

Stereo Separation: 35dB at 1kHz

THD: 0.5%

IF Frequency: 10.7MHz

**AM Tuner Section:**

Frequency Range: AM;530~1620kHz

Usable Sensitivity: 30dB (S/N 20dB)

Selectivity: 50dB(±10kHz)

IF Frequency: 450kHz

**Cassette Deck Section:**

Tape System: Auto-reverse

Stereo Separation: 35dB at 1kHz

Track System: 4-track 2 channel  
stereo playback**Intercom Section:**

Mic Input Impedance: 200Ω

Head set Output: 1W(8Ω/ch)

**AF Section:**

Auto volume level: +8 ~ +16dB

Tone volume level: +8 ~ -8dB

Weights and dimensions shown are approximate.

Design and specifications are subject to change without notice.

## HONDA/Panasonic.

Matsushita Services Company  
50 Meadowland Parkway,  
Secaucus, New Jersey 07094

Panasonic Hawaii, Inc.  
91-238, Kauhū St. Ewa Beach  
P.O. Box 774  
Honolulu, Hawaii 96808-0774

Panasonic Sales Company,  
Division of Matsushita Electric  
of Puerto Rico, Inc.  
Ave. 65 De Infantería, Km. 9.7  
Victoria Industrial Park  
Carolina, Puerto Rico 00630

## CONTENTS

ITEM	PAGE
• Location of Controls and Components .....	3
• Audio System Connection .....	4
• Disassembly Instructions. ....	5, 6
• Schematic Diagram (Main) .....	7~9
• Schematic Diagram (Volume/Tone, Power, Connector, Switch Motor/Plunger, Back-Up/Plunger) .....	10~12
• Circuit Board and Wiring Connection Diagram .....	13~15
• Measurements and Adjustments .....	16~18
• IC9 ( $\mu$ PD1714GA929) Each Terminal Function .....	19
• Cabinet Parts Location .....	20~22
• Mechanism Parts Location .....	23, 24
• Parts List .....	25~32

This service manual is only applicable to model RM-1500A.  
 It is inapplicable to optional equipment and accessories.

# LOCATION OF CONTROLS AND COMPONENTS

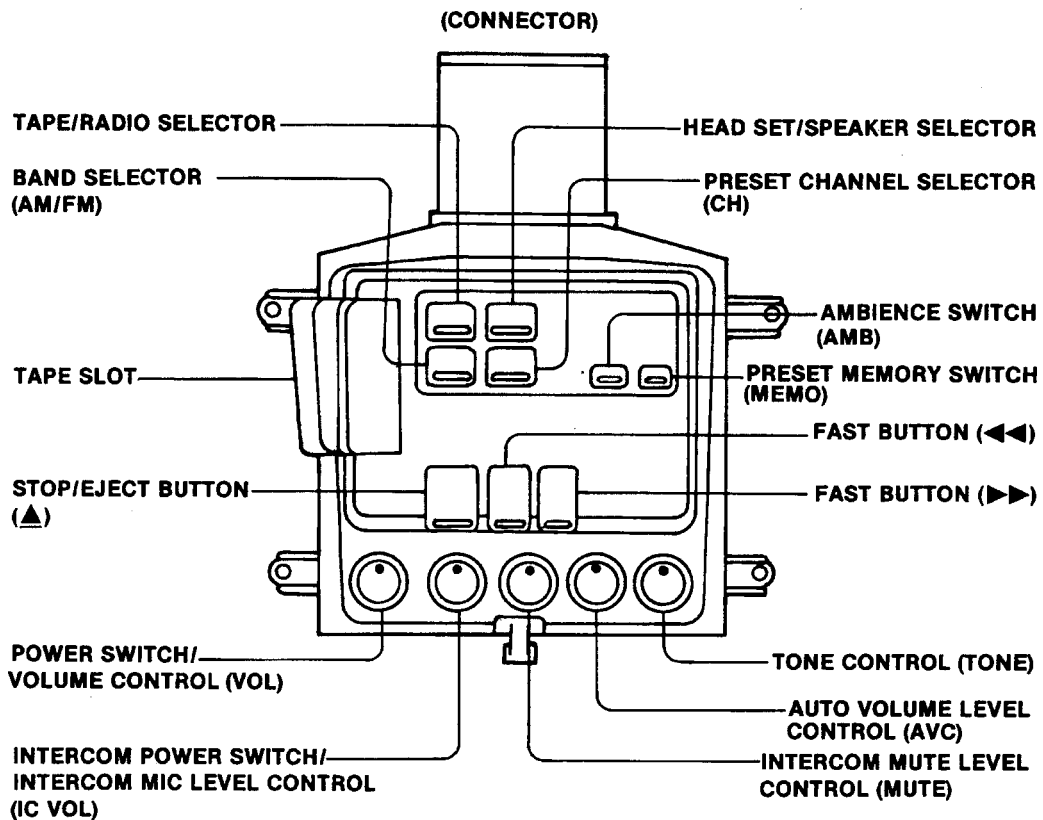

## < CONNECTOR >

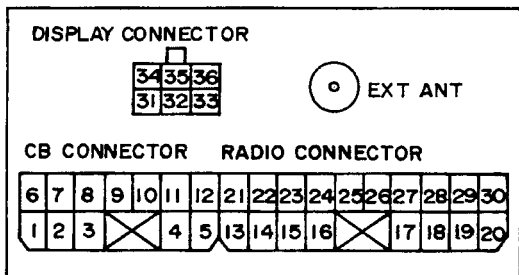

### ■ CB CONNECTOR

- |             |                  |
|-------------|------------------|
| 1. NOT USED | 7. CB AF E       |
| 2. CB AF HS | 8. HS/SP         |
| 3. CB AF SP | 9. CB AUDIO MUTE |
| 4. NOT USED | 10. GND OUT      |
| 5. NOT USED | 11. CB MIC OUT   |
| 6. CB ON    | 12. CB MIC E     |

### ■ RADIO CONNECTOR

- |                 |             |
|-----------------|-------------|
| 13. MIC PA      | 25. FL SP ⊕ |
| 14. MIC E PA    | 26. FL SP ⊖ |
| 15. HS OUT E    | 27. TUNE DN |
| 16. HS OUT L    | 28. MUTE    |
| 17. FR SP ⊖     | 29. TUNE UP |
| 18. FR SP ⊕     | 30. BACK UP |
| 19. SPEED PULSE |             |
| 20. ACC         |             |
| 21. MIC DR      |             |
| 22. MIC E DR    |             |
| 23. HS OUT R    |             |
| 24. GND         |             |

### ■ DISPLAY CONNECTOR

- |            |
|------------|
| 31. DATA   |
| 32. GND    |
| 33. BK     |
| 34. CLOCK  |
| 35. LOAD   |
| 36. K-MUTE |

### OPTION

CB Transceiver, CB Antenna, Head Set, Passenger Controller, Fader Volume, Rear Speaker.

# AUDIO SYSTEM CONNECTION

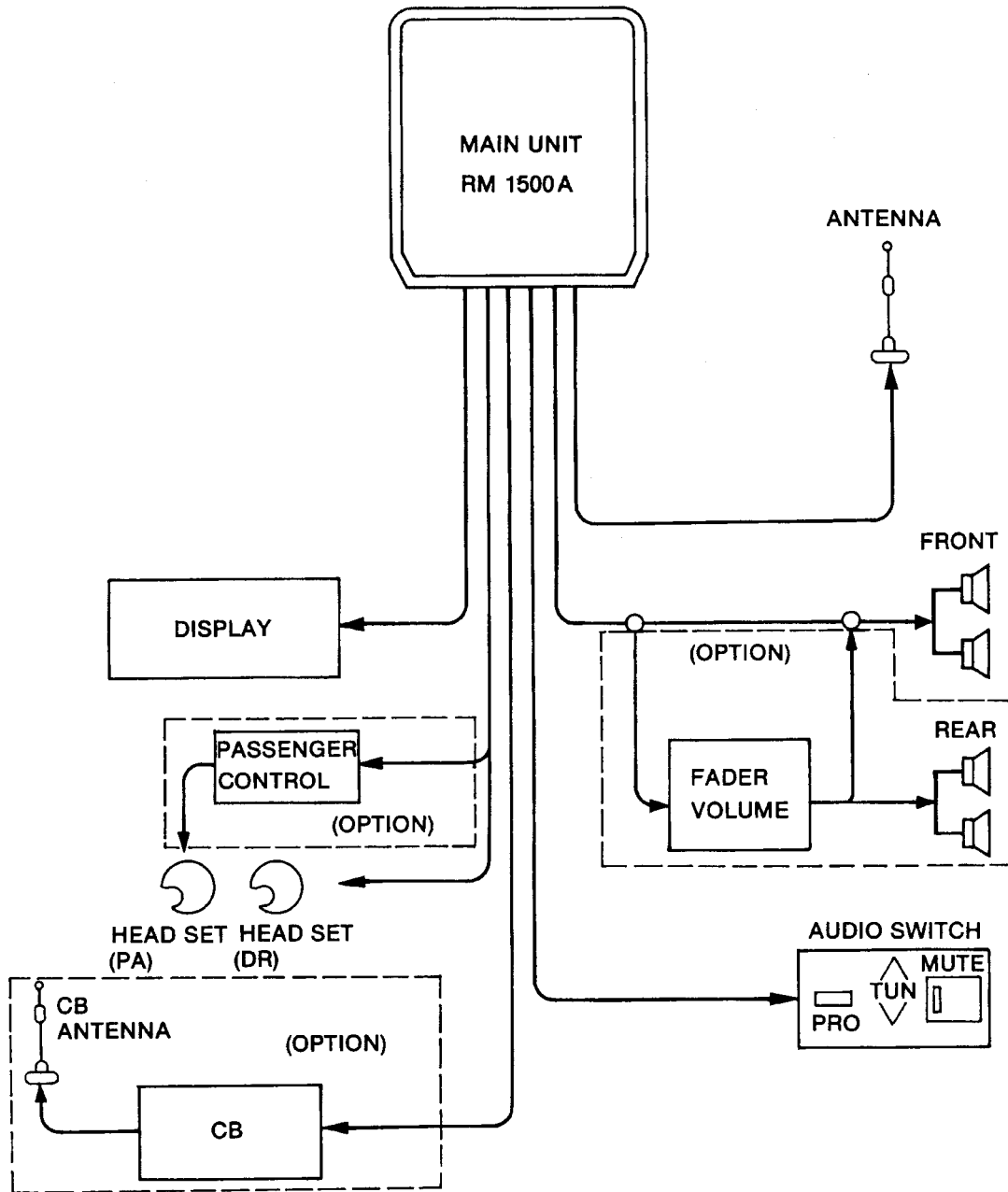

# DISASSEMBLY INSTRUCTIONS

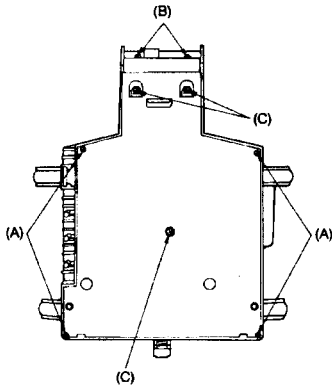

Fig. 1

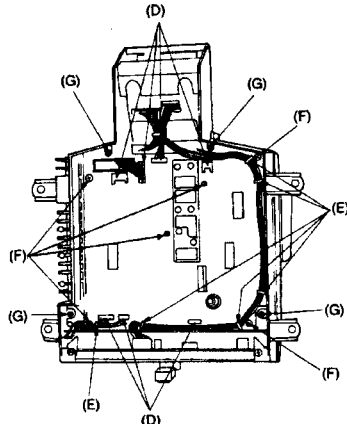

Fig. 2

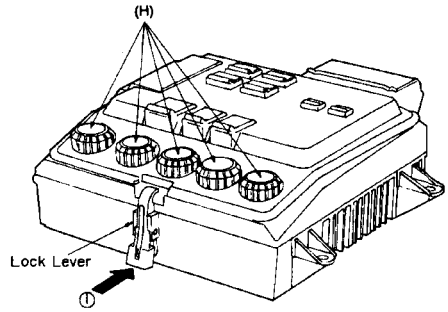

Fig. 3

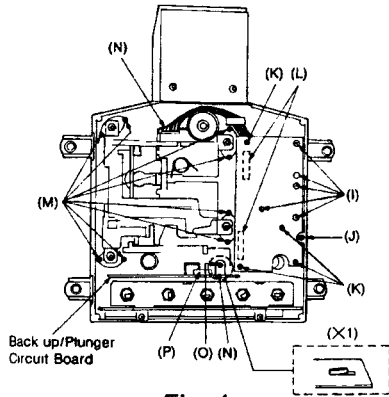

Fig. 4

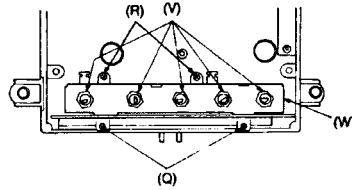

Fig. 5

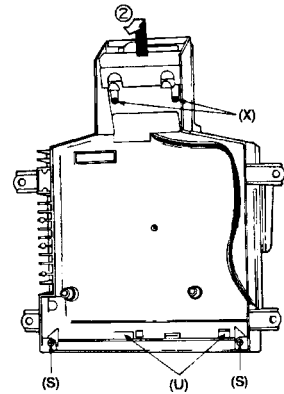

Fig. 6

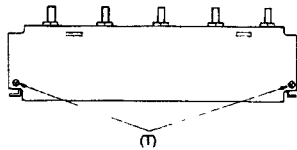

Fig. 7

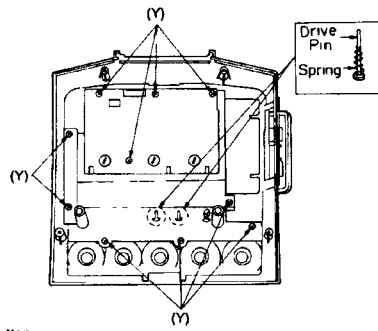

Fig. 8

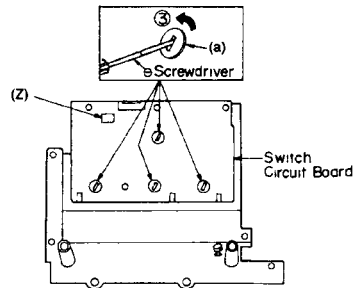

Fig. 9

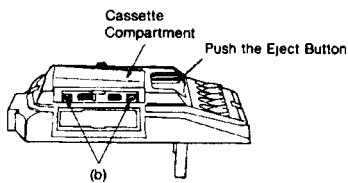
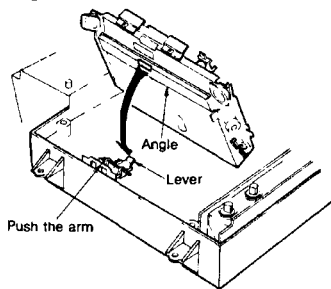

Fig. 10

Steps	Shown in Fig —	To remove —	Remove —
1	1	Bottom Cover	Screw (3 × 8)mm (A) × 4
2			Screw (3 × 12)mm (B) × 2
3			Screw (3 × 6)mm (C) × 3
4	2	Main Circuit Board	Socket (CN101, CN102, CN103, CN104, CN105, CN106, CN107) (D) × 7
5			Cut the wire tie (E) × 6
6			Screw (3 × 12)mm (F) × 6
7	2	Upper Cabinet Ass'y	Screw (3 × 10)mm (G) × 4
8	3		Knob (H) × 5
9			Push the lock lever in the direction of arrow ①
10	4	Power Amp Circuit Board	Screw (3 × 12)mm (I) × 5
11			Screw (J) × 1
12			Screw (3 × 8)mm (K) × 4
13			Socket (CN409, CN410) (L) × 2
14	4	Mechanism Unit	Screw (M) × 8
15			Socket (CN617, CN801) (N) × 2
16	4	Back up/Plunger Circuit Board (※1)	Screw (O) × 1
17			Socket (CN618) (P) × 1
18	5	Volume Circuit Board	Screw (3 × 8)mm (Q) × 2
19			Screw (R) × 2
20			Screw (3 × 8)mm (S) × 2
21	7	Volume Circuit Board	Screw (T) × 2
22	6		Socket (CN308, CN313) (U) × 2
23	5		Nut (V) × 5
24		Angle (W) × 1	
25	6	Power Supply Circuit Board	Screw (3 × 6)mm (X) × 2
26			Remove the power supply circuit board in the direction of arrow ②
27	8	Switch Circuit Board Chassis (※2)	Screw (3 × 10)mm (Y) × 10
28	9	Switch Circuit Board	Socket (CN702) (Z) × 1
29			Lamp (a) × 4 To remove the lamp, use a standard screwdriver and turn in the direction of arrow ③
30	10	Cassette Compartment	Push the eject button
31			Screw (3 × 10)mm (b) × 2

(※1) One of the lugs is bent, so after removing the screw (M), remove the circuit board while turning it to accommodate the angle of the lug

(※2) When removing the switch circuit board chassis, the drive pin and spring may come off, so be careful not to lose them.



**Mechanism attachment**

- (1) Push the arm to raise the lever
- (2) Attach the mechanism by inserting the lever into the mechanism at the shown angle

▼ Be sure to fold at the (▼) mark so that the mark is on the outside

# SCHEMATIC DIAGRAM (MAIN)

1 2 3 4 5 6 7 8 9 10 11 12 13

A  
B  
C  
D  
E  
F  
G  
H  
I

- Notes**
- S202 1~S202-3 Head switch in "FWD" position (F FWD, R REV)
  - VR1 FM VCO adjustment VR
  - DC voltage measurement are taken with electronics voltmeter from negative terminal of battery
- No mark Playback position, < > FM ( ) AM  RADIO  
<< >> FF/REW
- The mark (■) shows test point, e.g. TP1= test point 1
  - The supply parts number is described alone in the replacement parts list
- This schematic diagram may be modified at any time with the development of new technology

- Radio (FM) Signal Line
- Radio (AM) Signal Line
- Tape (PLAY) Signal Line
- Tape/Radio Signal Line
- +B Voltage Line
- FM VCO Signal Line
- AM VCO Signal Line
- FM/AM VCO Signal Line
- MIC Signal Line
- +B (BACK UP) Signal Line

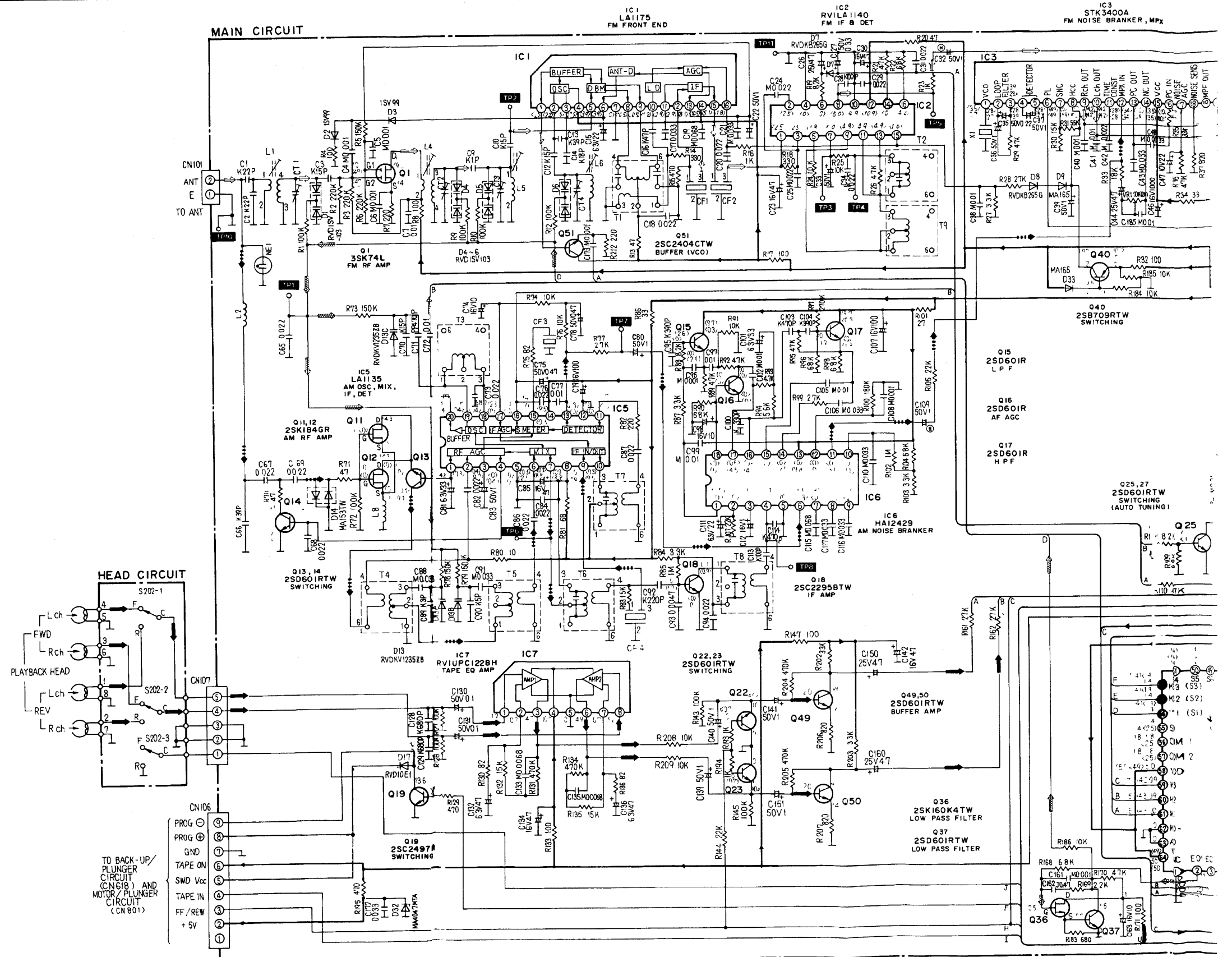

# SCHEMATIC DIAGRAM (MAIN)

6 7 8 9 10 11 12 13 14 15 16 17 18 19

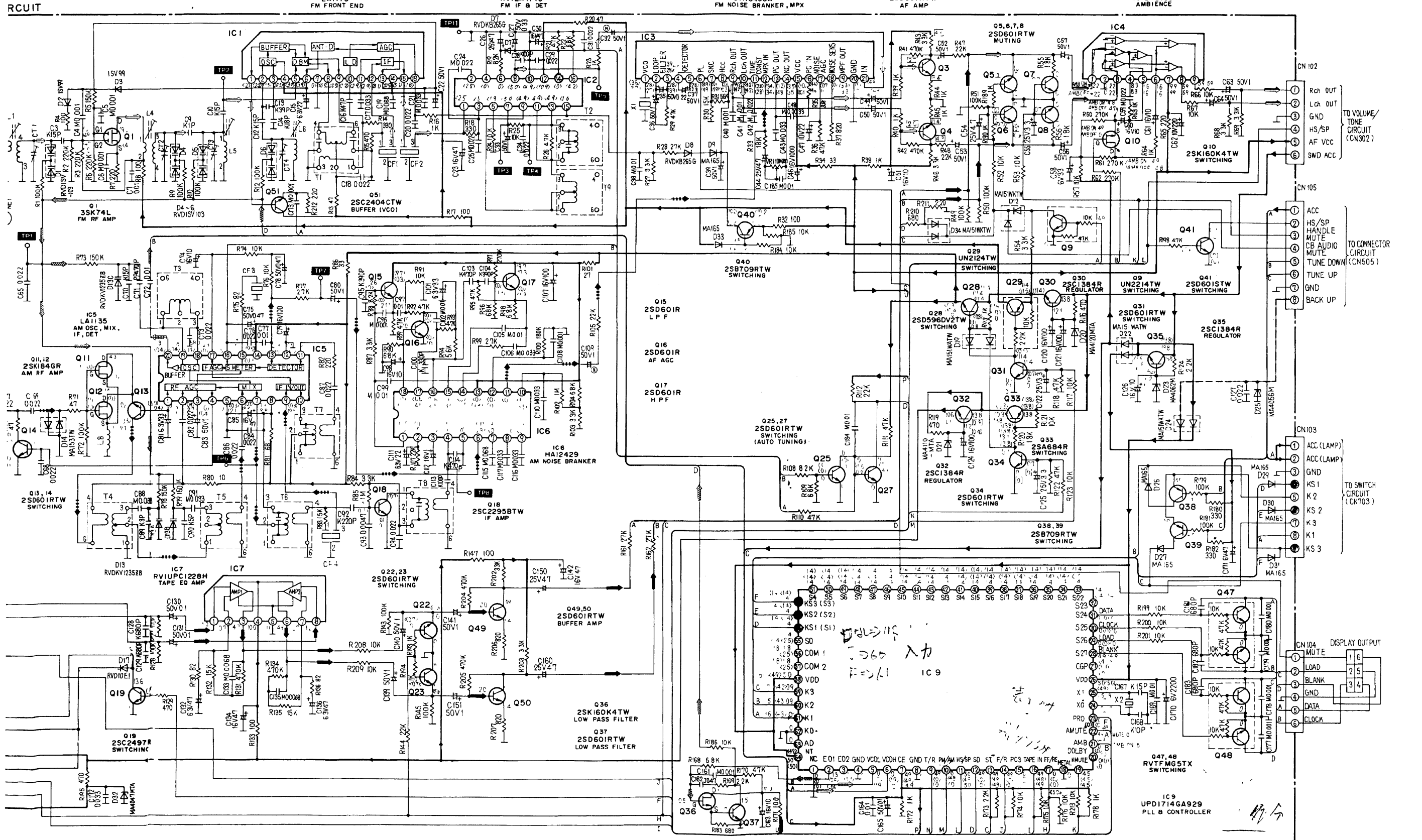



# SCHEMATIC DIAGRAM (VOLUME/TONE, POWER, CONNECTOR, SWITCH, MOTOR/PLUNGER, BACK-UP/PLUNGER)

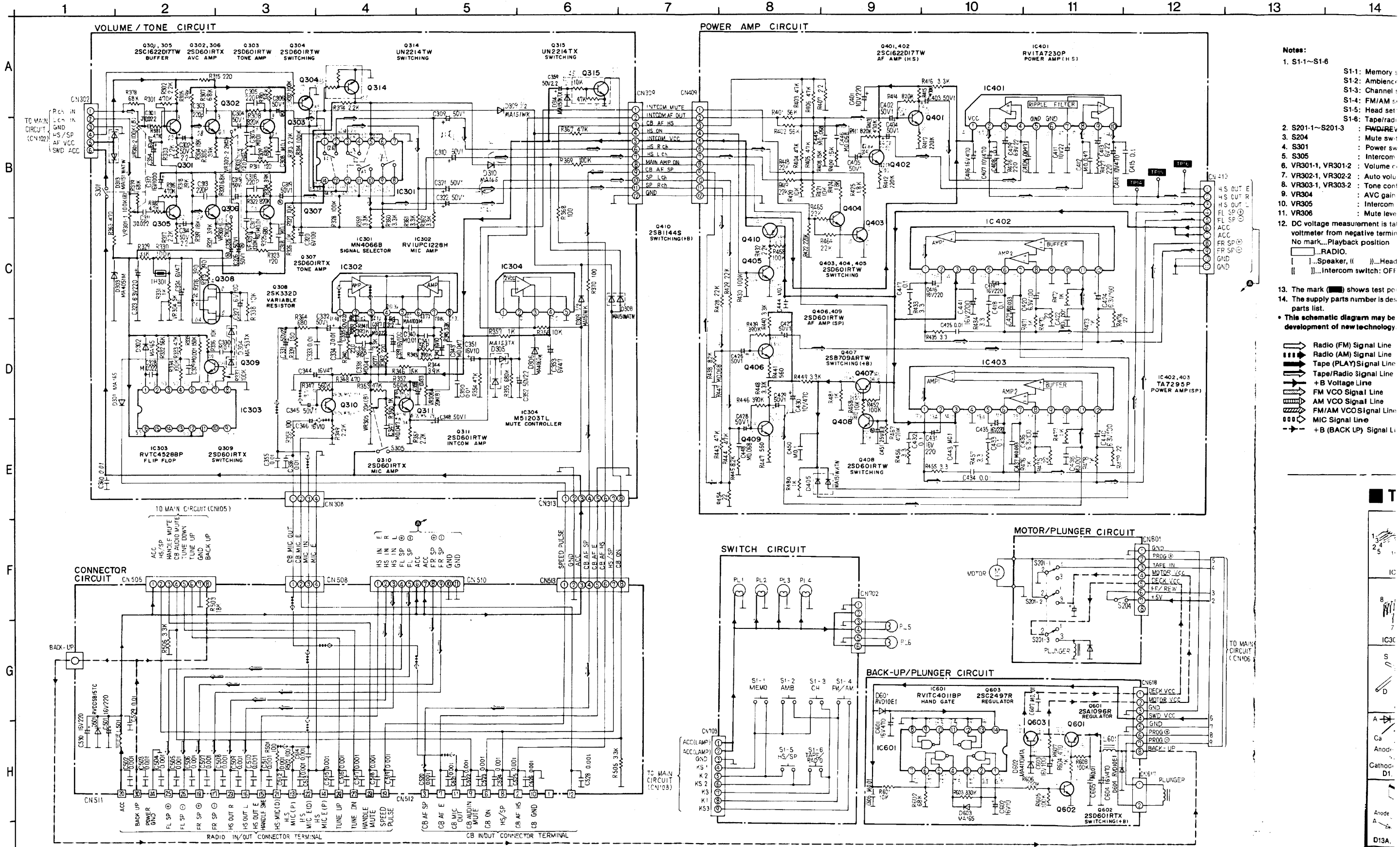

- Notes:**
- S1-1~S1-6
  - S201-1~S201-3
  - S204
  - S301
  - S305
  - VR301-1, VR301-2
  - VR302-1, VR302-2
  - VR303-1, VR303-2
  - VR304
  - VR305
  - VR306
12. DC voltage measurement is taken with voltmeter from negative terminal. No mark...Playback position. No mark...Speaker, ( )...Head. ( )...Intercom switch: OFF.
13. The mark (■) shows test point.  
14. The supply parts number is designated in this schematic diagram may be subject to development of new technology.

- Radio (FM) Signal Line
- Radio (AM) Signal Line
- Tape (PLAY) Signal Line
- Tape/Radio Signal Line
- +B Voltage Line
- FM VCO Signal Line
- AM VCO Signal Line
- FM/AM VCO Signal Line
- MIC Signal Line
- +B (BACK UP) Signal Line

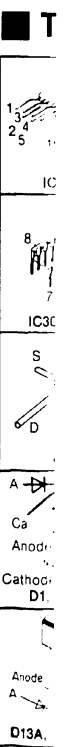

**ATIC DIAGRAM (VOLUME/TONE, POWER, CONNECTOR, SWITCH, MOTOR/PLUNGER, BACK-UP/PLUNGER)**

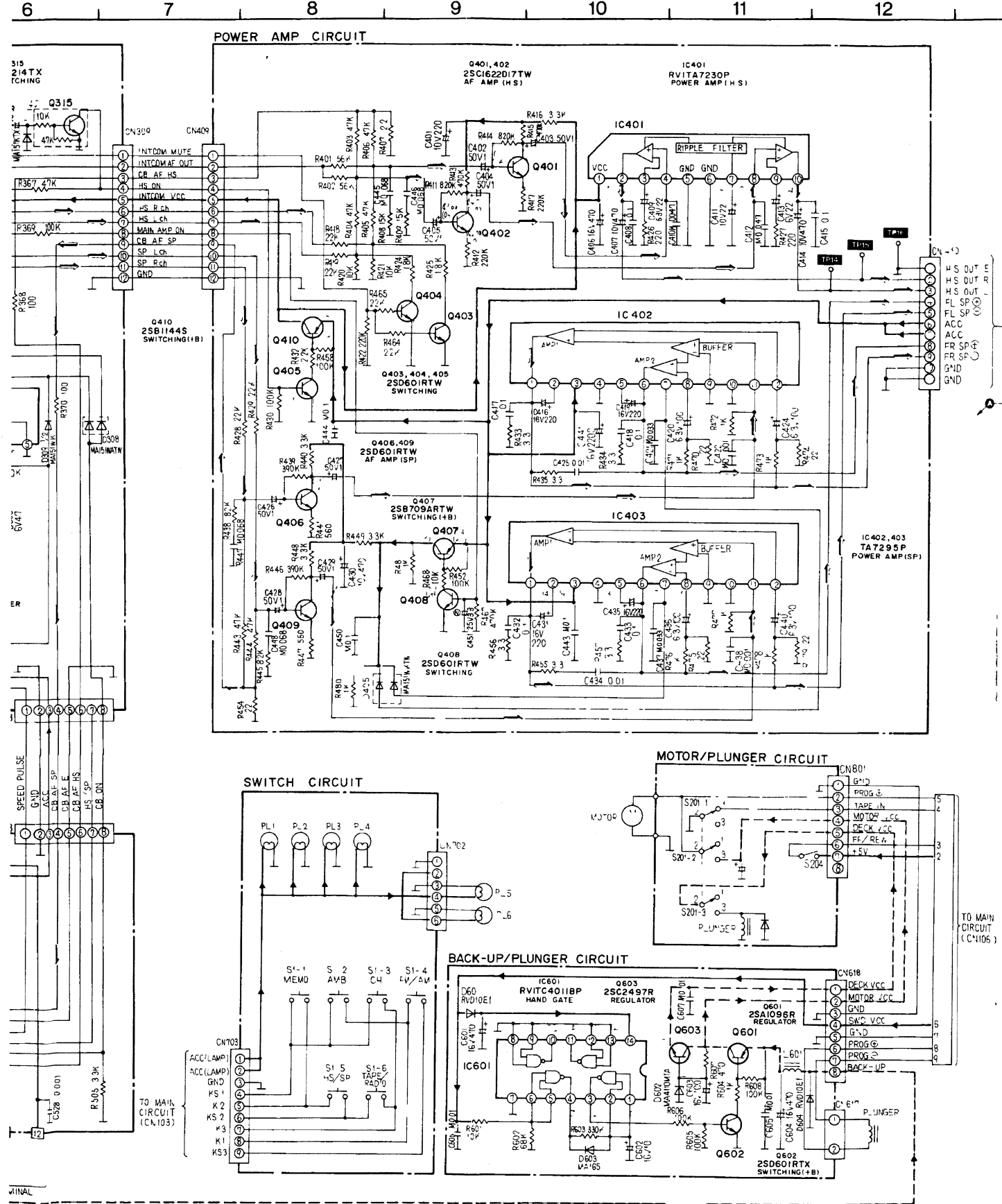

**Notes**

- 1 S11~S16
    - S1-1 Memory switch
    - S1-2 Ambience ON/OFF switch in "OFF" position
    - S1-3 Channel select switch
    - S1-4 FM/AM select switch
    - S1-5 Head set/speaker select switch
    - S1-6 Tape/radio select switch
  - 2 S201~S203 *FWD/REV select switch Cassette in switch*
  - 3 S204 *Mute switch -F/REV switch*
  - 4 S301 Power switch
  - 5 S305 Intercom ON/OFF switch
  - 6 VR301, VR301-2 Volume control VR
  - 7 VR302, VR302-2 Auto volume level control VR
  - 8 VR303-1, VR303-2 Tone control VR
  - 9 VR304 AVC gain adjustment VR
  - 10 VR305 Intercom mic level control VR
  - 11 VR306 Mute level control VR
- 12 DC voltage measurement is taken with an electronics voltmeter from negative terminal of battery  
No mark Playback position  
[ ] RADIO  
[ ] Speaker, ( ) Head Set  
[ ] Intercom switch OFF
- 13 The mark (■) shows test point, e.g. TPI = test point 1  
14 The supply parts number is described alone in the replacement parts list
- This schematic diagram may be modified at any time with the development of new technology

- ▶ Radio (FM) Signal Line
- ▶▶ Radio (AM) Signal Line
- ▶▶▶ Tape (PLAY) Signal Line
- ▶▶▶▶ Tape/Radio Signal Line
- ▶▶▶▶▶ +B Voltage Line
- ▶▶▶▶▶▶ FM VCO Signal Line
- ▶▶▶▶▶▶ AM VCO Signal Line
- ▶▶▶▶▶▶ FM/AM VCO Signal Line
- ▶▶▶▶▶▶ MIC Signal Line
- ▶▶▶▶▶▶ +B (BACK UP) Signal Line

**IC BLOCK DIAGRAM**

**IC2 RV1A1140**

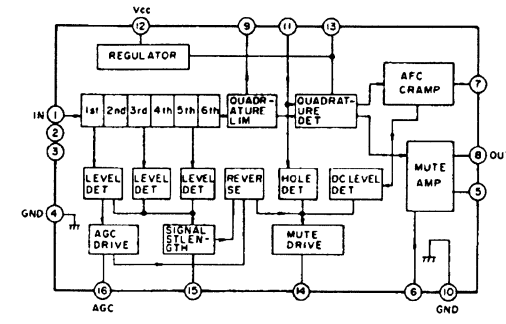

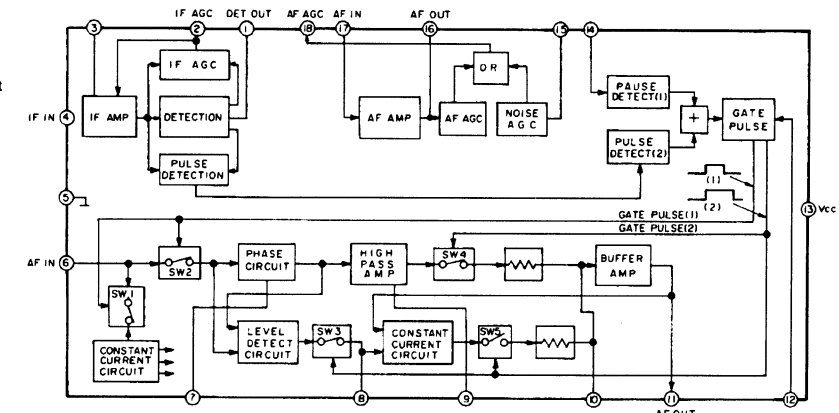

**IC6 HA12429**



**TERMINALS**

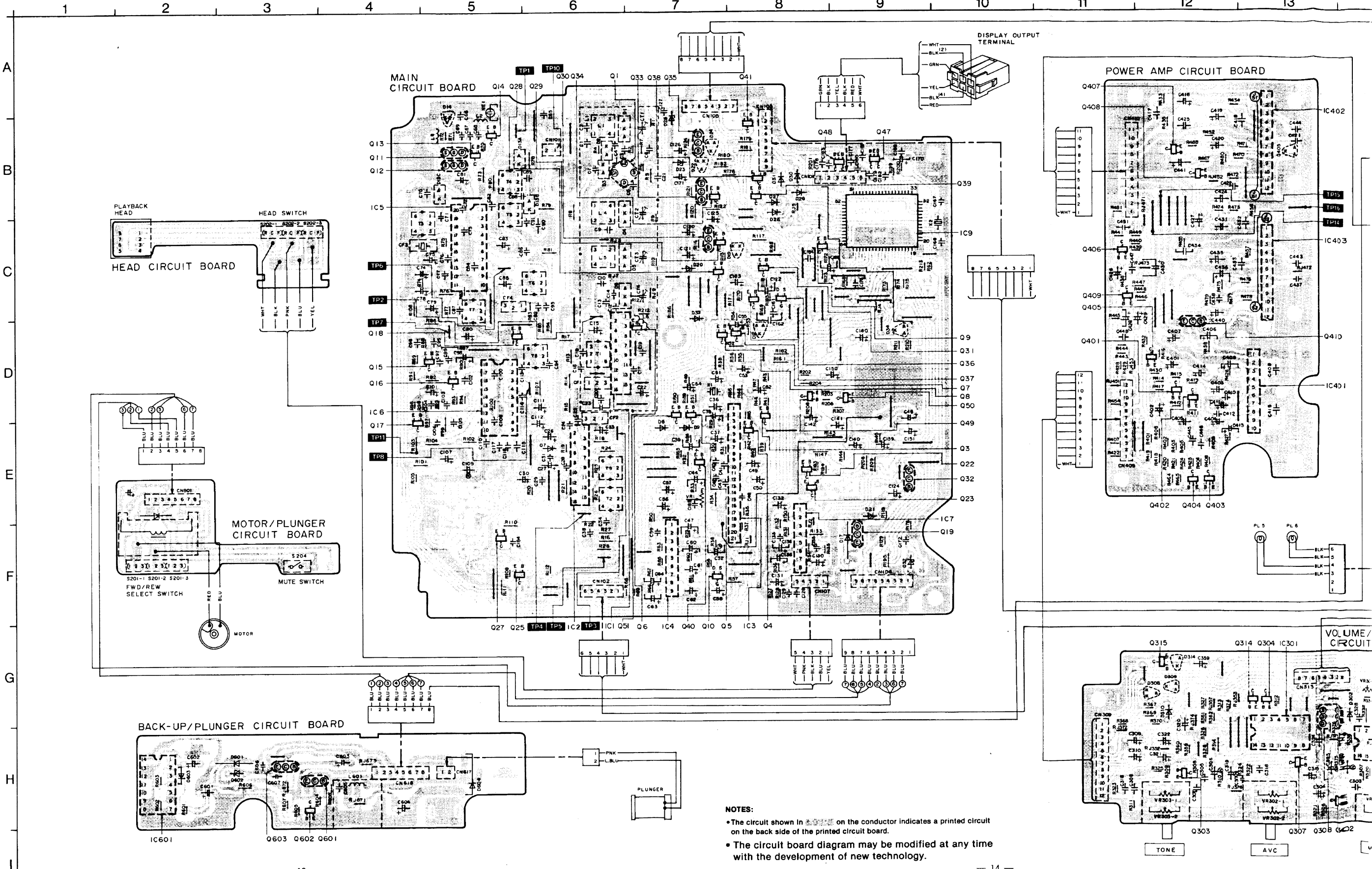

# CIRCUIT BOARD AND WIRING CONNECTION DIAGRAM



- NOTES:**
- The circuit shown in  on the conductor indicates a printed circuit on the back side of the printed circuit board.
  - The circuit board diagram may be modified at any time with the development of new technology.

# CIRCUIT BOARD AND WIRING CONNECTION DIAGRAM

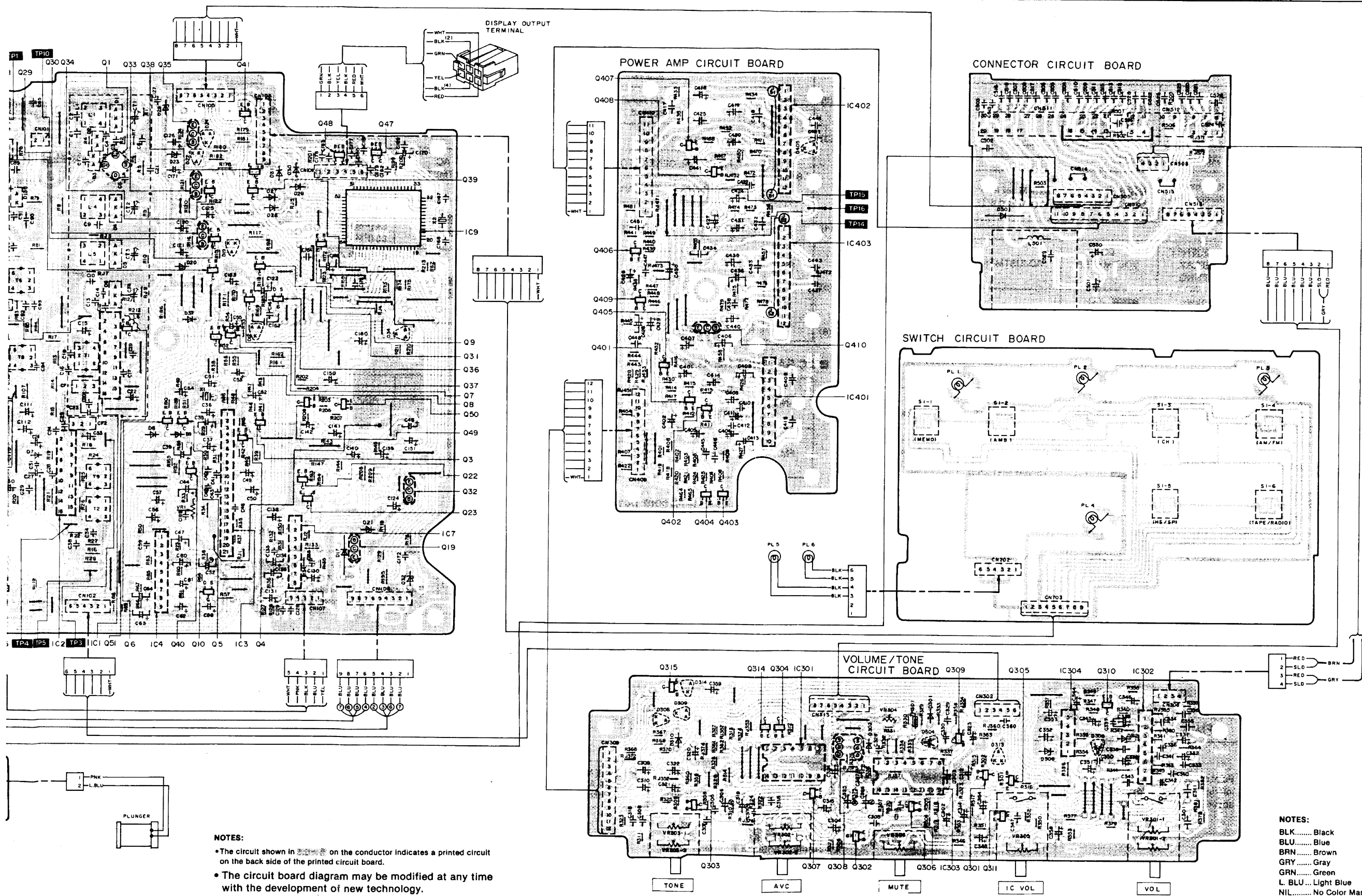
6 7 8 9 10 11 12 13 14 15 16 17 18 19



**NOTES:**

- The circuit shown in  on the conductor indicates a printed circuit on the back side of the printed circuit board.
- The circuit board diagram may be modified at any time with the development of new technology.

**NOTES:**

BLK.....Black	ORG.....Orange
BLU.....Blue	PNK.....Pink
BRN.....Brown	RED.....Red
GRY.....Gray	SLD.....Shield Wire
GRN.....Green	VLT.....Violet
L. BLU...Light Blue	WHT.....White
NIL.....No Color Mark	YEL.....Yellow



# MEASUREMENTS AND ADJUSTMENTS

1. Set tone control to center.
2. Inter com VOL and MUTE control to center.
3. AVC control to center.
4. Set volume control to maximum.
5. Set band switch to AM, FM.
6. Set HS/SP select switch to SP.
7. Set ambience switch to OFF.
8. Set power source voltage to 14V DC.

## AM IF ALIGNMENT

BAND	SIGNAL GENERATOR or SWEEP GENERATOR		FREQUENCY DISPLAY SETTING	INDICATOR (ELECTRONICS VOLTMETER or SCOPE)	ADJUSTMENT	REMARKS
	CONNECTIONS	FREQUENCY				
AM-IF ALIGNMENT						
(1) AM	 TP1 ... (+) TP2 ... (-)	450 kHz 30% Mod. at 400 Hz	Point of non-interference. (on/ about 600 kHz)	 TP3 ... (+) TP4 ... (-)	T6 (AM 1st IFT) T7 (AM 2nd IFT)	Adjust for maximum output.

## AM RF ALIGNMENT

BAND	AM SIGNAL GENERATOR		FREQUENCY DISPLAY SETTING	DC VOLTMETER	ADJUSTMENT	REMARKS
	CONNECTIONS	FREQUENCY				
(1) AM	Disconnect	No signal applied	530 kHz (CH1)	 TP1 ... (+) TP2 ... (-)	—	Adjust for 1.2 ± 1.6 V reading on DC voltmeter
(2) AM	Disconnect	No signal applied	1620 kHz (CH5)	 TP1 ... (+) TP2 ... (-)	—	Adjust for 6.7 ± 7.5 V reading on DC voltmeter
(3)	Repeat steps (1) and (2).					

BAND	AM SIGNAL GENERATOR		FREQUENCY DISPLAY SETTING	AC VOLT METER	ADJUSTMENT	REMARKS
	CONNECTIONS	FREQUENCY				
(4) AM	Connect to antenna socket through AM RF dummy antenna. (Refer to Fig. 2)	690 kHz	600 kHz (CH2)	 TP1 ... (+) TP2 ... (-)	T4 (AM ANT 1st) T5 (AM ANT 2nd)	Adjust for maximum reading on AC voltmeter
(5)	Repeat steps (4) and (5).					

## AM NB ALIGNMENT

BAND	AM SIGNAL GENERATOR		FREQUENCY DISPLAY SETTING	OSCILLOSCOPE	ADJUSTMENT	REMARKS
	CONNECTIONS	FREQUENCY				
AM	Connect to antenna socket through AM RF dummy antenna. (Refer to Fig. 2)	600 kHz (400 Hz, 0% Mod. 74 dB)	600 kHz	 TP1 ... (+) TP2 ... (-)	T8 (AM NB)	Adjust for maximum wave on the oscilloscope.

## FM ALIGNMENT

BAND	SIGNAL GENERATOR or SWEEP GENERATOR		FREQUENCY DISPLAY SETTING	INDICATOR (ELECTRONICS VOLTMETER or SCOPE)	ADJUSTMENT	REMARKS
	CONNECTIONS	FREQUENCY				
FM-IF ALIGNMENT						
(1) FM	High side thru. TP2 to test point. Negative side to TP1.	10.7 MHz SWP.	Point of non-interference. (on/ about 90 MHz)	Connect vert. amp. of scope to test point TP2. Negative side to test point TP1.	T1 (FM 1st IFT)	Adjust for maximum amplitude. (Refer to Fig. 4)
(2) FM	—	—	—	—	T2 (FM 2nd IFT)	Adjust for maximum amplitude. (Refer to Fig. 5)

## FM RF ALIGNMENT

BAND	FM SIGNAL GENERATOR		FREQUENCY DISPLAY SETTING	DC VOLTMETER	ADJUSTMENT	REMARKS
	CONNECTIONS	FREQUENCY				
(1) FM	Disconnect	No signal applied	87.5 MHz (CH1)	 TP1 ... (+) TP2 ... (-)	L6 (FM OSC Coil)	Adjust for 1.0 ± 0.05 V reading on DC voltmeter.
(2) FM	Disconnect	No signal applied	107.9 MHz (CH5)	 TP1 ... (+) TP2 ... (-)	CT4 (FM OSC Trimmer)	Adjust for 8 ± 0.1 V reading on DC voltmeter.
(3)	Repeat steps (1) and (2).					
BAND	FM SIGNAL GENERATOR		FREQUENCY DISPLAY SETTING	AC VOLTMETER	ADJUSTMENT	REMARKS
	CONNECTIONS	FREQUENCY				
(4) FM	Antenna socket (FM RF Dummy Fig. 3)	90.1 MHz (400 Hz 30%)	90.1 MHz (CH2)	 TP1 ... (+) TP2 ... (-)	L1 (FM ANT 1st) L4 (FM ANT 2nd) L5 (FM ANT 3rd)	Adjust for maximum reading on AC voltmeter
(5) FM	—	106.1 MHz (400 Hz 30%)	106.1 MHz (CH4)	 TP1 ... (+) TP2 ... (-)	CT1 (FM ANT 1st) CT2 (FM ANT 2nd) CT3 (FM ANT 3rd)	—
(6)	Repeat steps 4 and 5.					

## DC BALANCE NB ALIGNMENT

BAND	FM SIGNAL GENERATOR		FREQUENCY DISPLAY SETTING	DC VOLTMETER (center "0")	ADJUSTMENT	REMARKS
	CONNECTIONS	FREQUENCY				
FM	Antenna socket	90.1 MHz (400 Hz, 30% Mod, 60 dB)	90.1 MHz	 TP1 ... (+) TP2 ... (-)	T2	Adjust T2 for -0.05 ~ +0.05 V reading on DC voltmeter.

## FM SEPARATION (Intercom power switch to off)

CIRCUIT	SIGNAL GENERATOR	FREQUENCY COUNTER	AC VOLTMETER	ADJUSTMENT	REMARKS
SEPARATION	90.1 MHz (400 Hz, 30% Mod, 74 dB)	—	 TP1 ... Lch (+) TP2 ... Rch (+) TP3 ... (-)	VR1 (Separation)	Make adjustment so that when the antenna input is subjected to L modulation (or R modulation) R channel output (or L channel output) becomes minimum.

## AZIMUTH ALIGNMENT

TAPE	MEASUREMENT POINT	SPECIFICATION	ADJUSTMENT	REMARKS
QZZCFM (8 kHz, -20 dB)	 TP1 ... Lch (+) TP2 ... Rch (+) TP3 ... (-)	Maximum output	Azimuth Screw (Refer to Fig. 6)	Playback mode (FWD & REV)

## AVC GAIN ALIGNMENT

FM SIGNAL GENERATOR		FREQUENCY DISPLAY SETTING	SPECIFICATION	ADJUSTMENT	REMARKS
CONNECTIONS	FREQUENCY				
Connect to antenna socket through FM RF dummy antenna. (Refer to Fig. 3)	90.1 MHz (1 kHz, 30% Mod, 60 dB)	90.1 MHz	SP 50 mW (0.4 V/3Ω) = 0 Hz (0 dB)	VR304	• AVC Volume ... Center • Tone Volume ... Center • Adjust VR304 for 0 Hz (0 dB) → 100 Hz (5 ± 0.5 dB) reading on pulse.

Adjustment and Connection Procedures

< Adjustment Procedures >

1. Set the AVC VR (VR304) to the center position.
2. Adjust the VR for the volume adjustment so that the output of the speaker is 50mW (0.4V/3Ω).  
At this time, the output level should measure 0dB.
3. Set the AF Oscillator's output to 100Hz, 5Vp-p and send it to the connector.
4. Adjust the VR304 when the speaker's output has a value of 5dB ± 0.5dB.

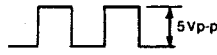

< Connection Scheme >

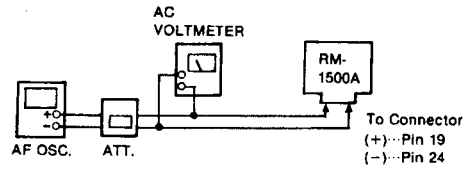

■ ALIGNMENT POINT

- Please refer to Circuit Board and Wiring Connection Diagram for test point locations.

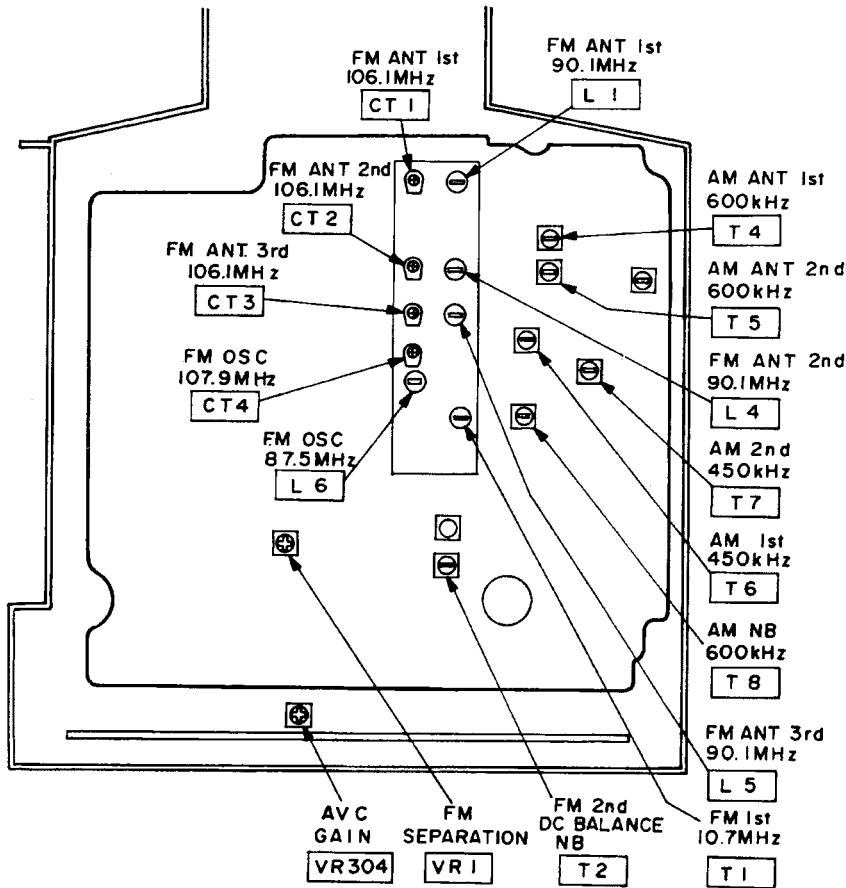

Fig. 1

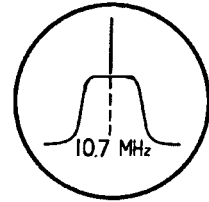

Fig. 4

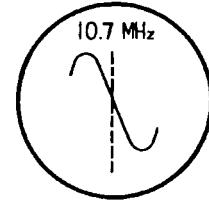
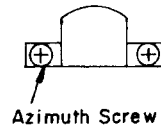

Fig. 5



Azimuth Screw

Fig. 6

■ AM RF DUMMY ANTENNA

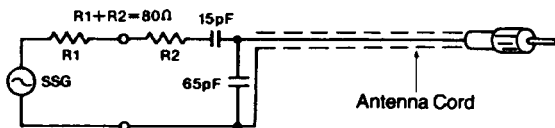

Fig. 2

■ FM RF DUMMY ANTENNA

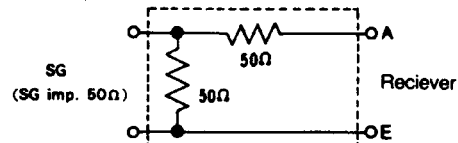
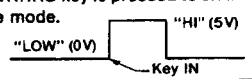

Fig. 3

# IC9 (UPD1714GA929) EACH TERMINAL FUNCTION

## ■ Explanation of each terminal

Pin No.	Mark	Pin Name	Function	Pin No.	Mark	Pin Name	Function
1	NC	—	—	15	PC3	—	—
2	E01	PLL error output	This pin provides the signal needed to control the tuning circuit (antenna and OSC) for each band. The signal appearing at this pin is coupled to an L.P.F. (Q36, 37), which controls varactor diodes D1-4, 6, 13. The local OSC and reference frequencies applied to pins 5 and 6 are compared. If the local OSC frequency exceeds the reference, this pin is set high; if it is lower than the reference, it is set low; if they are identical, this pin floats.	16	TAPE IN	Tape load input	Checks if a cassette tape is loaded. High level: Cassette tape loaded. Low level: No Cassette tape loaded.
3	E02	PLL error output	—	17	FF/RE	Tape FF/REW switching input	Accepts on FF/REW switching signal. High level: FF/REW Low level: <del>REW</del> PLAY
4, 8	GND	Ground	Connected to ground.	18	METAL	Metal tape input	Checks whether the loaded tape is a metal tape or not. High level: Metal tape Low level: Non-metal (normal) tape
5	V <sub>LOL</sub>	AM local OSC signal input	This pin accepts an AM Local OSC signal from IC5 (pin 20) as an AM tuning circuit control signal.	19	K MUTE	Mute signal input	Accepts a Mute signal when a key operation is made. High level: Muting on Low level: Muting off
6	V <sub>LOH</sub>	FM local OSC signal input	This pin accepts an FM Local OSC signal from IC1 (pin 1) as an FM tuning circuit control signal.	20	Dolby	Dolby on/off signal output	Provides a Dolby on/off signal. High level: Dolby on (In) Low level: Dolby off (Out) This signal switches transistor Q24 on or off to control the Dolby IC, IC8 (pins 3 and 18).
7	CE	Chip Enable input	Accepts a Chip Enable signal: High level...All device functions are enabled. Low level...All device inputs are disabled (except Memory Hold).	21	AMB	Ambience on/off signal output	Provides an Ambience on/off signal. High level: Ambience operation on Low level: Ambience operation off
9	T/R	Tape/Radio mode switching output	Provides a Tape/Radio Switching signal: High level: Tape mode, switching transistor Q34 is turned on to supply power to the tape circuit. Low level: Radio mode, Q34 is turned off, which then turns Q28 on to supply power to the radio circuit.	22	A MUTE	Mute signal output	If the Mute on/off signal is applied to pin 17 of the device, this pin yields a Muting signal to the base of Q9. High level: Muting off Low level: Muting on
10	FM/AM	Radio band switching output	Provides an FM/AM band switching signal: High level: FM mode, a high level is applied to the base of transistor Q31 to turn it on, this pulls the base of Q29 low and turns it on to supply power to the FM circuit. Low level: AM mode, a low level is applied to the base of transistor Q31 to turn it off, this pulls the base of Q28 high and turns it on to supply power to the AM circuit.	23	RR0	Cassette deck program switching output	Provides a pulse signal if the TUNE DOWN/IRO key is pressed to on in the Tape mode. 
11	HS/SP	Headphones/speaker switching signal output	Provides a headphones/speaker switching signal. High level: Selects the speaker. Low level: Selects the headphones.	24, 25	X <sub>0</sub> , X <sub>1</sub>	Crystal resonator inputs	A 4.5 MHz crystal resonator is connected across these pins.
12	SD	Auto-tuning detection input	If a station is encountered during auto-tuning, a high level signal is applied to this pin to stop tuning scan.	26	VDD	Power supply input	Accepts a +5V power.
13	ST	FM stereo/mono signal input	Provides an FM stereo/mono switching signal to IC3 (pin 6). High level: FM mono mode Low level: FM stereo mode	27	CGP	—	—
14	F/R	FWD/REV switching input	Accepts a FWD/REV switching signal. High level: FWD operation Low level: REV operation	28	S27	LCD driving signal (blank) output	Provides an LCD driving signal to Q48.
				29	S26	LCD driving signal (load) output	Provides an LCD driving signal to Q48.
				30	S25	LCD driving signal clock output	Provides an LCD driving signal to Q47.
				31	S24	LCD driving signal data output	Provides LCD display data to Q47.
				32 } 50 } 51 } 54 }	S23 ~S5	LCD segment signal outputs	—
				51 } 54 }	S4~S1	Key matrix signal outputs	Provides key matrix signals.
				55	S0	Key matrix signal output	—
				56, 57	COM1 COM2	LCD common signal output	—
				59 } 62 }	K3~K0	Key return signal inputs	Accept data signal lines from keys.

# CABINET PARTS LOCATION (Please refer to Cabinet Parts List on page 29.)

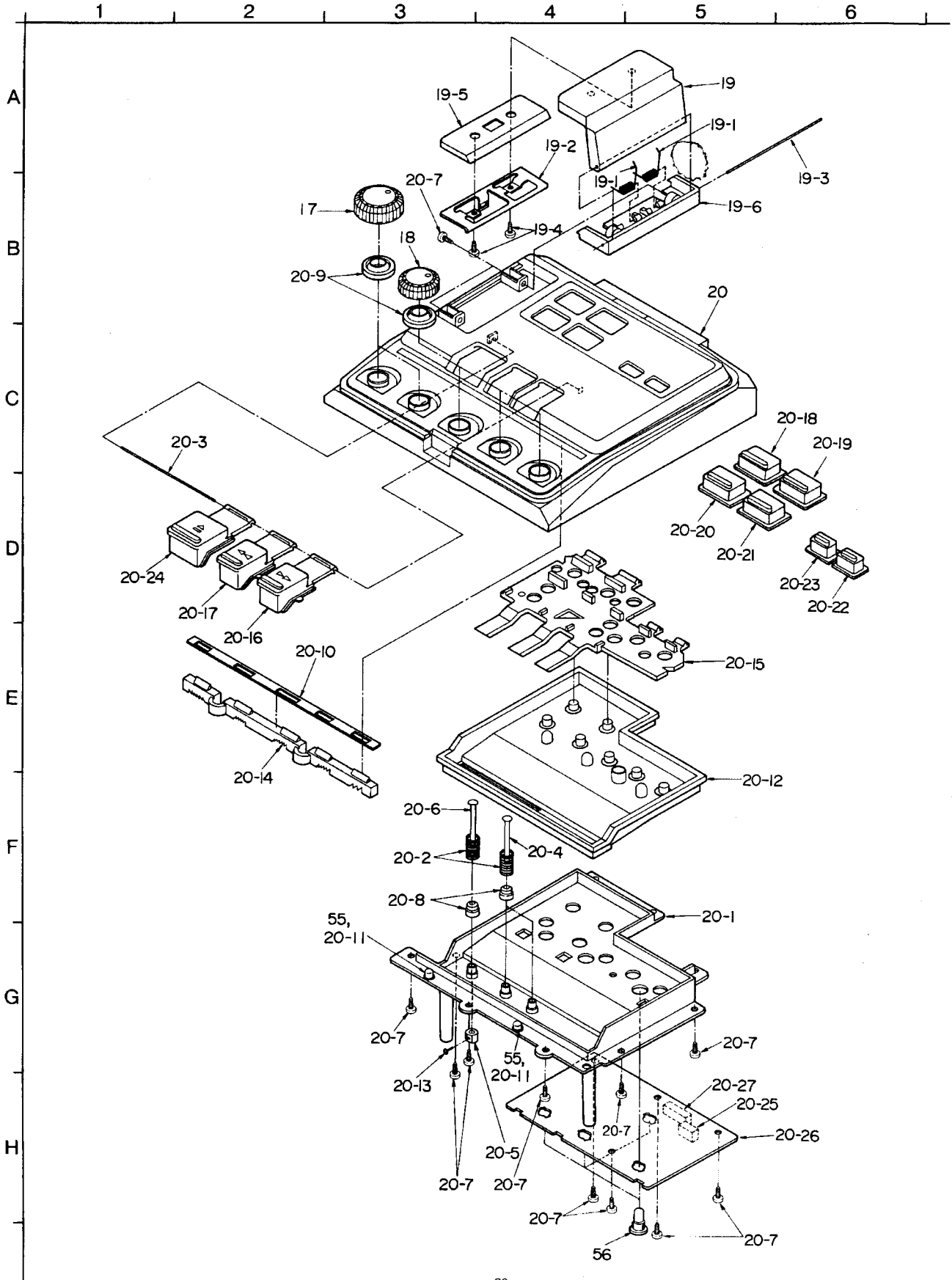



# CABINET PARTS LOCATION (Please refer to Cabinet Parts List on page 29.)

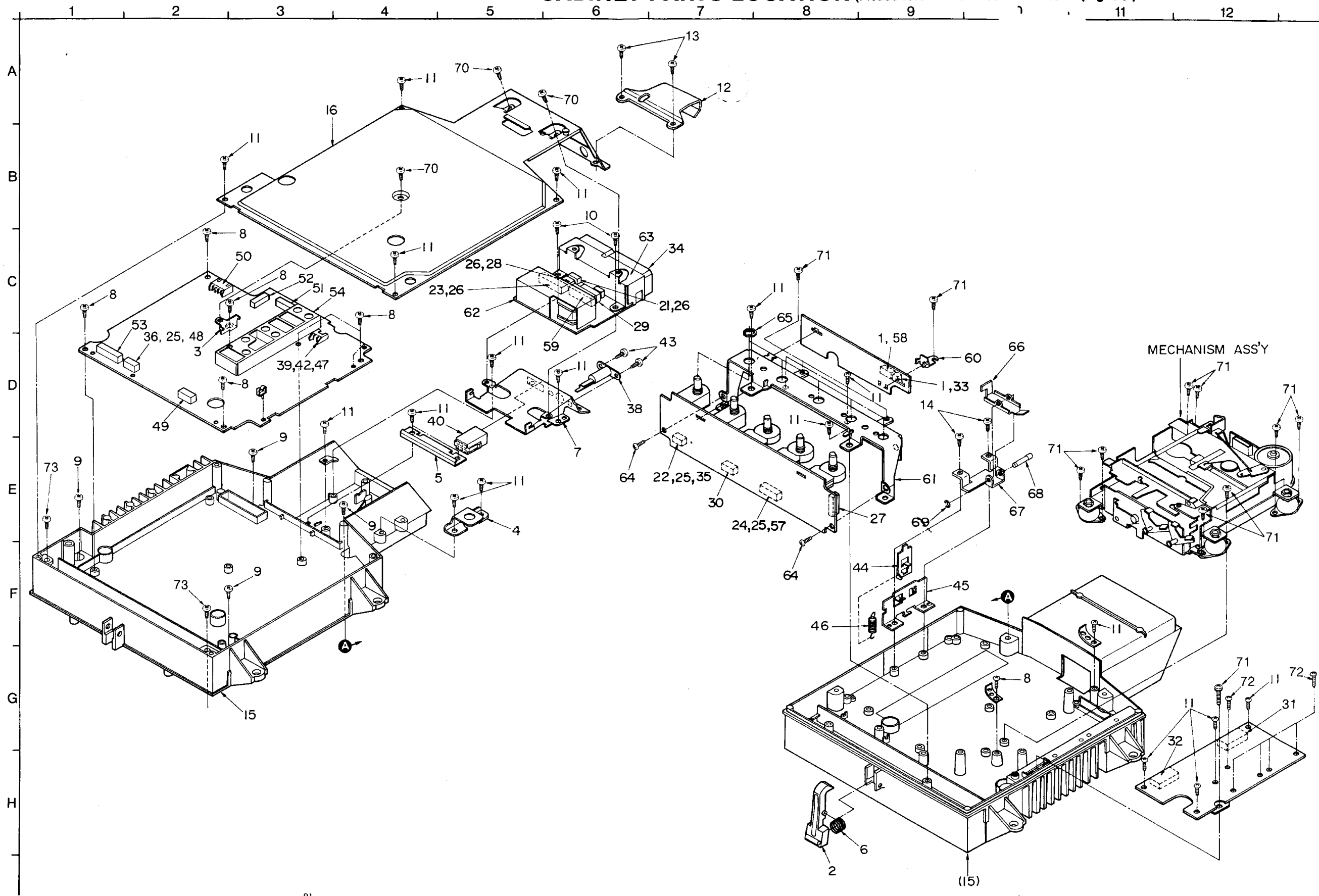

**MECHANISM PARTS LOCATION** (Please refer to Mechanism Parts List on page 30.)

1 2 3 4 5 6 7 8 9 10 11 12 13

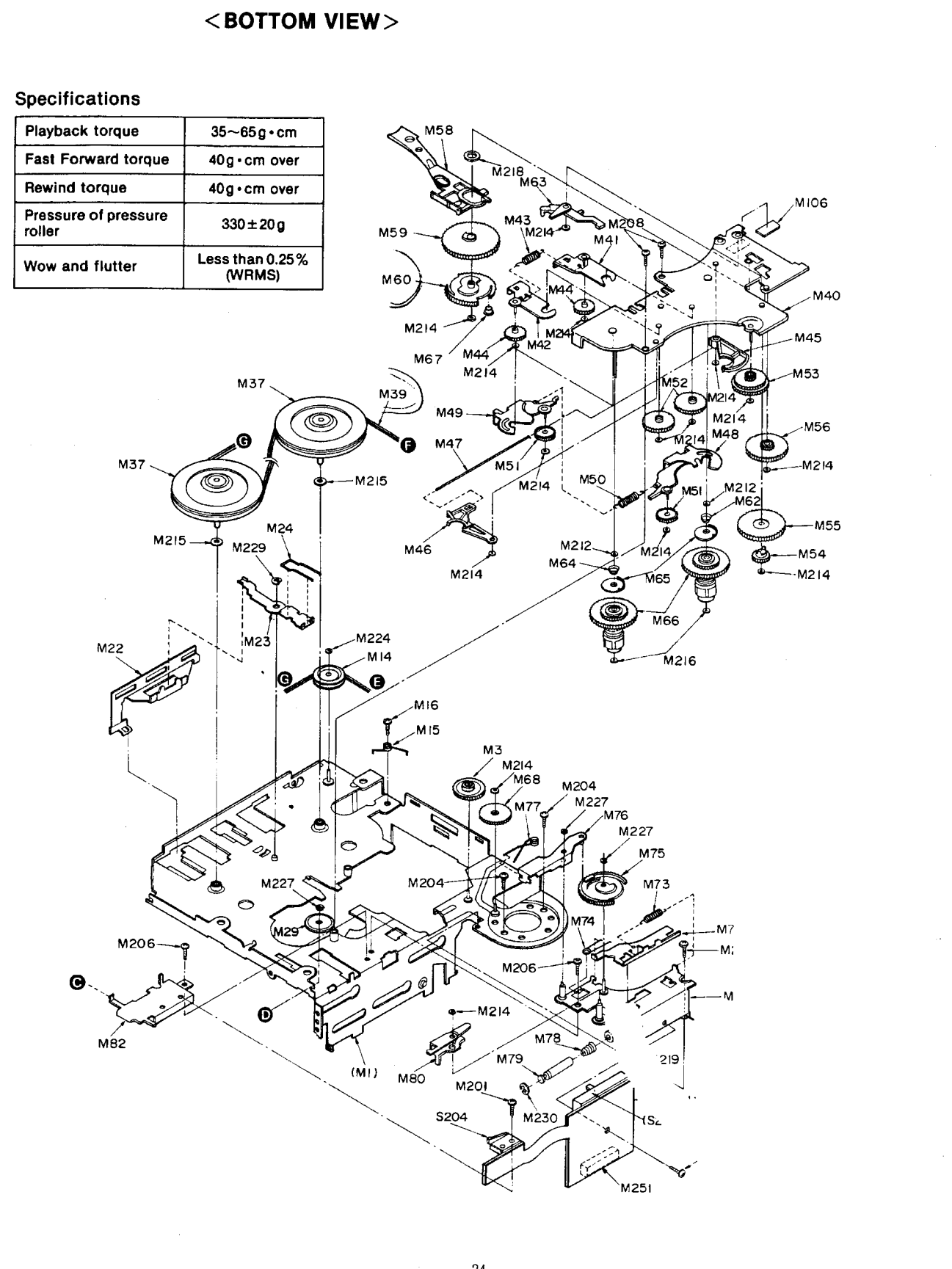
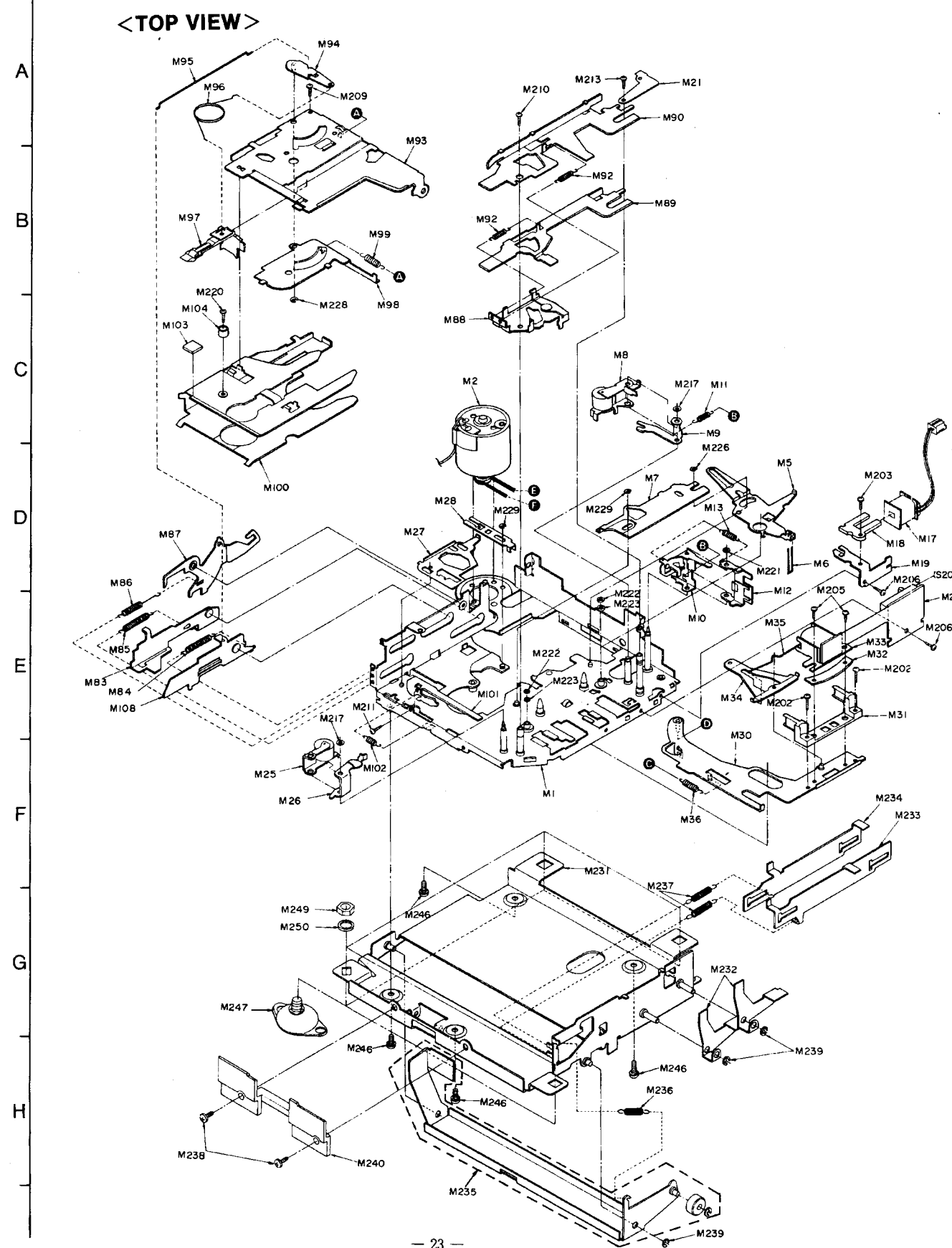

**Specifications**

Playback torque	35~65g·cm
Fast Forward torque	40g·cm over
Rewind torque	40g·cm over
Pressure of pressure roller	330 ± 20g
Wow and flutter	Less than 0.25% (WRMS)

# RESISTORS & CAPACITORS

**Notes :** \* Important safety notice :

Components identified by  $\Delta$  mark have special characteristics important for safety. When replacing any of these components use only manufacturer's specified parts.

\* Bracketed indications in Ref. No. columns specify the area. (Refer to the first page for area.)  
Parts without these indications can be used for all areas.

## Numbering System of Resistor

Example:

ERD	25	F	J	102
Type	Wattage (1/4W)	Shape	Tolerance	Value (1K $\Omega$ )
ERX	2	AN	J	471
Type	Wattage (2W)	Shape	Tolerance	Value (470 $\Omega$ )

## Numbering System of Capacitor

Example:

ECKD	1H	102	Z	F
Type	Voltage (50V)	Value (0.001 $\mu$ F)	Tolerance	Peculiarity
ECEA	50	M	330	
Type	Voltage (50V)	Peculiarity	Value (33 $\mu$ F)	

\* Capacity is stated in microfarads ( $\mu$ F) unless specified otherwise, P=Pico-farads.

\* Resistance is stated in ohms ( $\Omega$ ), unless specified otherwise, 1K=1,000 $\Omega$ , 1M=1,000K $\Omega$

Resistor Type	Wattage		Tolerance
ERD : Carbon	10 : 1/8W	12 : 1/2W	J : $\pm$ 5%
ERG : Metal Oxide	14 : 1/4W	25 : 1/4W	F : $\pm$ 1%
ERQ : Fuse Type Metal	1A : 1W	1B : 1/8W	G : $\pm$ 2%
ERX : Metal Film	S2 : 1/4W	S1 : 1/2W	J : $\pm$ 5%
ERD L : Carbon (chip)	2F : 1/4W	50 : 1/2W	K : $\pm$ 10%
ERO K : Metal Film (chip)	2A : 2W	3A : 3W	M : $\pm$ 20%
ERC : Solid	6G : 1/10W	8G : 1/8W	
ERF : Incombustible Box-Shaped			
ERM : Wire-Wound			
RRJ : Chip Resistor			
ERJ : Chip Resistor			

Capacitor Type	Voltage		Tolerance
ECE : Electrolytic	0J : 6.3V	1A : 10V	K : $\pm$ 10%
ECCD : Ceramic	1C : 16V	1E : 25V	M : $\pm$ 20%
ECKD : Ceramic Capacitor	1H : 50V	1V : 35V	Z : +80%
EQOM : Polyester	50 : 50V	05 : 50V	-20
ECOP : Polypropylene	2H : 500V	2A : 100V	J : $\pm$ 5%
ECG : Ceramic	1 : 100V	1J : 63V	G : $\pm$ 2%
ECEA N : Non Polar Electrolytic	KC : 400V AC		F : $\pm$ 1%
QCU : Ceramic (Chip Type)	KC : 125V AC	(UL)	C : $\pm$ 0.25pF
ECUX : Ceramic (Chip Type)			D : $\pm$ 0.5pF
ECF : Semiconductor			
EECW : Liquid electrolyte double layer capacitor			

Ref. No.	Part No.	Value.	Ref. No.	Part No.	Value.	Ref. No.	Part No.	Value.
RESISTORS(VALUE,WATTAGE)								
R1	RRJ6GCJ104TE	100K 1/10	R42	RRJ6GCJ474	470K 1/10	R86	ERDS2TJ330	33 1/4
R2	RRJ6GCJ224TE	220K 1/10	R43	RRJ6GCJ332TE	3.3K 1/10	R87	ERDS2TJ332	3.3K 1/4
R3	RRJ6GCJ224TE	220K 1/10	R44	RRJ6GCJ102TE	1K 1/10	R88	RRJ6GCJ822	8.2K 1/10
R4	RRJ6GCJ101TE	100 1/10	R45	RRJ6GCJ102TE	1K 1/10	R89	RRJ6GCJ472TE	4.7K 1/10
R5	ERDS2TJ154	150K 1/4	R46	ERDS2TJ332	3.3K 1/4	R90	RRJ6GCJ682TE	6.8K 1/10
R6	RRJ6GCJ224TE	220K 1/10	R47	RRJ6GCJ223TE	22K 1/10	R91	RRJ6GCJ103TE	10K 1/10
R7	RRJ6GCJ221TE	220 1/10	R48	ERDS2TJ223	22K 1/4	R92	ERDS2TJ472	4.7K 1/4
R8	ERDS2TJ101	100 1/4	R49	RRJ6GCJ104TE	100K 1/10	R93	RRJ6GCJ472TE	4.7K 1/10
R9	RRJ6GCJ104TE	100K 1/10	R50	RRJ6GCJ104TE	100K 1/10	R94	RRJ6GCJ562	5.6K 1/10
R10	RRJ6GCJ104TE	100K 1/10	R51	RRJ6GCJ104TE	100K 1/10	R95	RRJ6GCJ473TE	47K 1/10
R12	RRJ6GCJ104TE	100K 1/10	R52	ERDS2TJ103	10K 1/4	R96	RRJ6GCJ683TE	68K 1/10
R13	ERDS2TJ470	47 1/4	R53	RRJ6GCJ103TE	10K 1/10	R97	RRJ6GCJ274TE	270K 1/10
R14	ERDS2TJ331	330 1/4	R54	RRJ6GCJ332TE	3.3K 1/10	R98	RRJ6GCJ682TE	6.8K 1/10
R15	ERDS2TJ471	470 1/4	R55	RRJ6GCJ182	1.8K 1/10	R99	ERDS2TJ272	2.7K 1/4
R16	ERDS2TJ102	1K 1/4	R56	RRJ6GCJ182	1.8K 1/10	R100	RRJ6GCJ184TE	180K 1/10
R17	ERDS2TJ101	100 1/4	R57	ERDS2TJ103	10K 1/4	R101	ERDS2TJ270T	27 1/4
R18	ERDS2TJ331	330 1/4	R60	RRJ6GCJ274TE	270K 1/10	R102	ERDS2TJ105	1M 1/4
R19	RRJ6GCJ822	8.2K 1/10	R61	RRJ6GCJ274TE	270K 1/10	R103	ERDS2TJ332	3.3K 1/4
R20	RRJ6GCJ470TE	47 1/10	R62	RRJ6GCJ274TE	270K 1/10	R104	ERDS2TJ682	6.8K 1/4
R21	ERDS2TJ473	47K 1/4	R63	RRJ6GCJ102TE	1K 1/10	R105	RRJ6GCJ223TE	22K 1/10
R22	ERDS2TJ683	68K 1/4	R64	RRJ6GCJ102TE	1K 1/10	R107	ERDS2TJ223	22K 1/4
R23	RRJ6GCJ102TE	1K 1/10	R65	RRJ6GCJ221TE	220 1/10	R108	ERDS2TJ822	8.2K 1/4
R24	ERDS2TJ103	10K 1/4	R66	RRJ6GCJ103TE	10K 1/10	R109	RRJ6GCJ682TE	6.8K 1/10
R25	ERDS2TJ103	10K 1/4	R67	RRJ6GCJ103TE	10K 1/10	R110	ERDS2TJ473	47K 1/4
R26	ERDS2TJ472	4.7K 1/4	R68	RRJ6GCJ332TE	3.3K 1/10	R111	ERDS2TJ473	47K 1/4
R27	ERDS2TJ332	3.3K 1/4	R69	RRJ6GCJ332TE	3.3K 1/10	R112	RRJ6GCJ223TE	22K 1/10
R28	ERDS2TJ273	27K 1/4	R70	RRJ6GCJ470TE	47 1/10	R113	RRJ6GCJ102TE	1K 1/10
R29	RRJ6GCJ472TE	4.7K 1/10	R71	RRJ6GCJ470TE	47 1/10	R116	RRJ6GCJ471TE	470 1/10
R30	RRJ6GCJ153	15K 1/10	R72	RRJ6GCJ104TE	100K 1/10	R117	ERDS2TJ103	10K 1/4
R31	RRJ6GCJ562	5.6K 1/10	R73	ERDS2TJ154	150K 1/4	R118	RRJ6GCJ473TE	47K 1/10
R32	ERDS2TJ101	100 1/4	R74	RRJ6GCJ103TE	10K 1/10	R119	RRJ6GCJ471TE	470 1/10
R33	RRJ6GCJ183TE	18K 1/10	R75	RRJ6GCJ682TE	82 1/10	R120	ERDS2TJ182	1.8K 1/4
R34	ERDS2TJ330	33 1/4	R76	ERDS2TJ103	10K 1/4	R121	RRJ6GCJ103TE	10K 1/10
R35	RRJ6GCJ333	33K 1/10	R77	RRJ6GCJ272TE	2.7K 1/10	R122	ERDS2TJ473	47K 1/4
R36	RRJ6GCJ473TE	47K 1/10	R78	ERDS2TJ154	150K 1/4	R123	RRJ6GCJ103TE	10K 1/10
R37	RRJ6GCJ821TE	820 1/10	R79	ERDS2TJ154	150K 1/4	R124	RRJ6GCJ222TE	2.2K 1/10
R38	ERDS2TJ102	1K 1/4	R80	ERDS2TJ100	10 1/4	R127	RRJ6GCJ104TE	100K 1/10
R39	RRJ6GCJ102TE	1K 1/10	R81	ERDS2TJ680	68 1/4	R128	RRJ6GCJ104TE	100K 1/10
R40	RRJ6GCJ102TE	1K 1/10	R82	RRJ6GCJ221TE	220 1/10	R129	RRJ6GCJ471TE	470 1/10
R41	RRJ6GCJ474	470K 1/10	R83	RRJ6GCJ152	1.5K 1/10	R130	RRJ6GCJ820TE	82 1/10
			R84	ERDS2TJ332	3.3K 1/4	R131	RRJ6GCJ474	470K 1/10
			R85	ERDS2TJ105	1M 1/4	R132	RRJ6GCJ153	15K 1/10

Ref. No.	Part No.	Value.	Ref. No.	Part No.	Value.	Ref. No.	Part No.	Value.
R133	ERDS2TJ101	100 1/4	R329	RRJ6GCJ333	39K 1/10	R432	RRJ6GCJ222TE	2.2K 1/10
R134	RRJ6GCJ474	470K 1/10	R330	RRJ6GCJ104TE	100K 1/10	R433	RRJ6GCJ3R3TE	3.3 1/10
R135	RRJ6GCJ153	15K 1/10	R331	RRJ6GCJ102TE	1K 1/10	R434	RRJ6GCJ3R3TE	3.3 1/10
R136	RRJ6GCJ820TE	82 1/10	R332	ERDS2TJ563	56K 1/4	R435	RRJ6GCJ3R3TE	3.3 1/10
R143	RRJ6GCJ104TE	100K 1/10	R333	RRJ6GCJ472TE	4.7K 1/10	R438	RRJ6GCJ822	8.2K 1/10
R144	RRJ6GCJ223TE	22K 1/10	R334	RRJ6GCJ104TE	100K 1/10	R439	RRJ6GCJ394TE	390K 1/10
R145	RRJ6GCJ104TE	100K 1/10	R335	ERDS2TJ154	150K 1/4	R440	RRJ6GCJ332TE	3.3K 1/10
R147	ERDS2TJ101	100 1/4	R336	RRJ6GCJ103TE	10K 1/10	R441	RRJ6GCJ561TE	560 1/10
R161	ERDS2TJ273	27K 1/4	R337	RRJ6GCJ104TE	100K 1/10	R443	RRJ6GCJ473TE	47K 1/10
R162	ERDS2TJ273	27K 1/4	R338	RRJ6GCJ103TE	10K 1/10	R444	RRJ6GCJ473TE	47K 1/10
R168	RRJ6GCJ682TE	6.8K 1/10	R339	RRJ6GCJ151TE	150 1/10	R445	RRJ6GCJ822	8.2K 1/10
R169	RRJ6GCJ222TE	2.2K 1/10	R340	RRJ6GCJ271TE	270 1/10	R446	RRJ6GCJ394TE	390K 1/10
R170	RRJ6GCJ472TE	4.7K 1/10	R341	RRJ6GCJ394TE	390K 1/10	R447	RRJ6GCJ561TE	560 1/10
R171	ERDS2TJ101	100 1/4	R342	RRJ6GCJ221TE	220 1/10	R448	RRJ6GCJ332TE	3.3K 1/10
R172	RRJ6GCJ102TE	1K 1/10	R343	RRJ6GCJ394TE	390K 1/10	R449	RRJ6GCJ332TE	3.3K 1/10
R173	RRJ6GCJ222TE	2.2K 1/10	R344	RRD18XJ392V	3.9K 1/8	R452	RRJ6GCJ104TE	100K 1/10
R174	RRJ6GCJ103TE	10K 1/10	R345	RRJ6GCJ332TE	3.3K 1/10	R454	RRJ6GCJ220TE	22 1/10
R175	RRJ6GCJ103TE	10K 1/10	R346	RRJ6GCJ153	15K 1/10	R455	RRJ6GCJ3R3TE	3.3 1/10
R176	RRJ6GCJ103TE	10K 1/10	R347	RRJ6GCJ564TE	560K 1/10	R456	RRJ6GCJ3R3TE	3.3 1/10
R178	ERDS2TJ102	1K 1/4	R348	RRJ6GCJ471TE	470 1/10	R457	RRJ6GCJ3R3TE	3.3 1/10
R179	ERDS2TJ104	100K 1/4	R349	RRJ6GCJ222TE	2.2K 1/10	R458	RRD18XJ104V	100K 1/8
R180	ERDS2TJ331	330 1/4	R350	RRJ6GCJ102TE	1K 1/10	R464	RRJ6GCJ223TE	22K 1/10
R181	ERDS2TJ104	100K 1/4	R351	RRJ6GCJ222TE	2.2K 1/10	R465	RRJ6GCJ223TE	22K 1/10
R182	ERDS2TJ331	330 1/4	R352	RRJ6GCJ564TE	560K 1/10	R467	RRJ6GCJ474	470K 1/10
R183	RRJ6GCJ681TE	680 1/10	R353	RRJ6GCJ473TE	47K 1/10	R468	RRJ6GCJ103TE	10K 1/10
R184	RRJ6GCJ103TE	10K 1/10	R354	RRJ6GCJ473TE	47K 1/10	R470	RRJ6GCJ220TE	22 1/10
R185	RRJ6GCJ102TE	1K 1/10	R355	RRJ6GCJ684TE	680K 1/10	R471	RRJ6GCJ102TE	1K 1/10
R186	ERDS2TJ103	10K 1/4	R356	ERDS2TJ103	10K 1/4	R472	RRJ6GCJ102TE	1K 1/10
R189	RRJ6GCJ102TE	1K 1/10	R357	RRJ6GCJ102TE	1K 1/10	R473	RRJ6GCJ102TE	1K 1/10
R190	RRJ6GCJ102TE	1K 1/10	R358	RRJ6GCJ101TE	100 1/10	R474	RRJ6GCJ220TE	22 1/10
R193	RRJ6GCJ102TE	1K 1/10	R359	RRJ6GCJ332TE	3.3K 1/10	R475	RRJ6GCJ220TE	22 1/10
R194	RRJ6GCJ102TE	1K 1/10	R360	RRJ6GCJ332TE	3.3K 1/10	R476	RRJ6GCJ102TE	1K 1/10
R195	ERDS2TJ471	470 1/4	R361	RRJ6GCJ332TE	3.3K 1/10	R477	RRJ6GCJ102TE	1K 1/10
R198	RRJ6GCJ473TE	47K 1/10	R362	RRJ6GCJ332TE	3.3K 1/10	R478	RRJ6GCJ102TE	1K 1/10
R199	RRJ6GCJ103TE	10K 1/10	R363	RRJ6GCJ471TE	470 1/10	R479	RRJ6GCJ220TE	22 1/10
R200	RRJ6GCJ103TE	10K 1/10	R364	RRJ6GCJ681TE	680 1/10	R480	RRJ6GCJ102TE	1K 1/10
R201	RRJ6GCJ103TE	10K 1/10	R367	RRJ6GCJ473TE	47K 1/10	R481	RRJ6GCJ102TE	1K 1/10
R202	RRJ6GCJ332TE	3.3K 1/10	R368	RRJ6GCJ101TE	100 1/10	R501	RRJ6GCJ101TE	100 1/10
R203	RRJ6GCJ332TE	3.3K 1/10	R369	RRJ6GCJ104TE	100K 1/10	R502	RRJ6GCJ101TE	100 1/10
R204	RRJ6GCJ474	470K 1/10	R370	RRJ6GCJ101TE	100 1/10	R503	RRJ6GCJ183TE	18K 1/10
R205	RRJ6GCJ474	470K 1/10	R374	RRJ6GCJ222TE	2.2K 1/10	R505	RRJ6GCJ332TE	3.3K 1/10
R206	RRJ6GCJ821TE	820 1/10	R375	RRJ6GCJ391TE	390 1/10	R506	RRJ6GCJ332TE	3.3K 1/10
R207	RRJ6GCJ821TE	820 1/10	R376	RRJ6GCJ391TE	390 1/10	R601	RRJ6GCJ103TE	10K 1/10
R208	ERDS2TJ103	10K 1/4	R377	RRJ6GCJ332TE	3.3K 1/10	R602	RRJ6GCJ683TE	68K 1/10
R209	ERDS2TJ103	10K 1/4	R378	RRJ6GCJ683TE	68K 1/10	R603	RRJ6GCJ334TE	330K 1/10
R210	RRJ6GCJ681TE	680 1/10	R379	RRJ6GCJ683TE	68K 1/10	R604	RRJ6GCJ102TE	1K 1/10
R211	RRJ6GCJ221TE	220 1/10	R380	RRJ6GCJ392	3.9K 1/10	R605	RRJ6GCJ104TE	100K 1/10
R212	RRJ6GCJ221TE	220 1/10	R381	RRJ6GCJ472TE	4.7K 1/10	R606	ERDS2TJ104	100K 1/4
R213	RRJ6GCJ103TE	10K 1/10	R382	RRJ6GCJ472TE	4.7K 1/10	R607	RRJ6GCJ471TE	470 1/10
R301	RRJ6GCJ474	470K 1/10	R401	RRJ6GCJ563TE	56K 1/10	R608	RRJ6GCJ104TE	100K 1/10
R302	RRJ6GCJ222TE	2.2K 1/10	R402	RRJ6GCJ563TE	56K 1/10	RJ1	RRJ6GCJ000TE	
R303	RRJ6GCJ222TE	2.2K 1/10	R403	RRJ6GCJ473TE	47K 1/10	RJ2	RRJ6GCJ000TE	
R304	RRJ6GCJ183TE	18K 1/10	R404	RRJ6GCJ473TE	47K 1/10	RJ4	RRJ6GCJ000TE	
R305	RRJ6GCJ393TE	39K 1/10	R405	RRJ6GCJ473TE	47K 1/10	RJ5	RRJ6GCJ000TE	
R306	RRJ6GCJ392	3.9K 1/10	R406	RRJ6GCJ473TE	47K 1/10	RJ7	RRJ6GCJ000TE	
R307	RRD18XJ682V	6.8K 1/8	R407	RRJ6GCJ2R2TE	2.2 1/10	RJ8	RRJ6GCJ000TE	
R308	RRJ6GCJ824TE	820K 1/10	R408	RRJ6GCJ153	15K 1/10	RJ9	RRJ6GCJ000TE	
R309	RRJ6GCJ681TE	680 1/10	R409	RRJ6GCJ153	15K 1/10	RJ352	RRJ6GCJ000TE	
R310	RRJ6GCJ392	3.9K 1/10	R411	RRJ6GCJ824TE	820K 1/10	RJ353	RRJ6GCJ000TE	
R311	RRJ6GCJ121TE	120 1/10	R412	RRJ6GCJ221TE	220 1/10	RJ354	RRJ6GCJ000TE	
R312	RRJ6GCJ104TE	100K 1/10	R413	RRJ6GCJ471TE	470 1/10	RJ355	RRJ6GCJ000TE	
R313	RRJ6GCJ222TE	2.2K 1/10	R414	RRJ6GCJ824TE	820K 1/10	RJ357	RRJ6GCJ000TE	
R314	ERDS2TJ104	100K 1/4	R415	RRJ6GCJ471TE	470 1/10	RJ360	RRJ6GCJ000TE	
R315	RRJ6GCJ221TE	220 1/10	R416	RRJ6GCJ332TE	3.3K 1/10	RJ371	RRD18XJ000V	
R316	RRJ6GCJ474	470K 1/10	R417	RRJ6GCJ221TE	220 1/10	RJ372	RRD18XJ000V	
R317	RRJ6GCJ222TE	2.2K 1/10	R418	RRJ6GCJ223TE	22K 1/10	RJ373	RRD18XJ000V	
R318	RRJ6GCJ393TE	39K 1/10	R419	RRJ6GCJ223TE	22K 1/10	RJ374	RRD18XJ000V	
R319	RRJ6GCJ183TE	18K 1/10	R420	RRJ6GCJ103TE	10K 1/10	RJ375	RRD18XJ000V	
R320	RRJ6GCJ682TE	6.8K 1/10	R421	RRJ6GCJ103TE	10K 1/10	RJ376	RRD18XJ000V	
R321	RRJ6GCJ392	3.9K 1/10	R422	RRJ6GCJ224TE	220K 1/10	RJ451	RRJ6GCJ000TE	
R322	RRJ6GCJ824TE	820K 1/10	R424	RRJ6GCJ182	1.8K 1/10	RJ452	RRJ6GCJ000TE	
R323	RRJ6GCJ121TE	120 1/10	R425	RRJ6GCJ182	1.8K 1/10	RJ453	RRJ6GCJ000TE	
R324	RRJ6GCJ392	3.9K 1/10	R426	RRJ6GCJ221TE	220 1/10	RJ471	RRD18XJ000V	
R325	RRJ6GCJ681TE	680 1/10	R427	RRJ6GCJ221TE	220 1/10	RJ472	RRD18XJ000V	
R326	RRJ6GCJ103TE	10K 1/10	R428	RRJ6GCJ223TE	22K 1/10	RJ473	RRD18XJ000V	
R327	RRJ6GCJ103TE	10K 1/10	R429	RRJ6GCJ223TE	22K 1/10	RJ571	RRD18XJ000V	
R328	RRD18XJ104V	100K 1/8	R430	RRJ6GCJ104TE	100K 1/10	RJ572	RRD18XJ000V	

Ref. No.	Part No.	Value.	Ref. No.	Part No.	Value.	Ref. No.	Part No.	Value.
RJ671	RRD18XJ000V		C76	RCUV1E223ZF	0.022 25	C177	RCUV1H102MD	0.001 50
RJ672	RRD18XJ000V		C77	RCUV1E103MD	0.01 25	C178	RCUV1H102MD	0.001 50
RJ673	RRD18XJ000V		C78	ECEA1HKR47B	0.47 50	C179	RCUV1H102MD	0.001 50
CAPACITORS(VALUE,VOLTAGE)			C79	ECEA1CK101B	100 16	C180	RCUV1H102MD	0.001 50
C1	RCUV1H220KC	22P 50	C80	ECEA1HK010B	1 50	C181	RCUV1H681K	680P 50
C2	RCUV1H220KC	22P 50	C81	ECEA0JK330B	33 6.3	C182	RCUV1H681K	680P 50
C3	RCUV1H150KC	15P 50	C82	RCUV1E223ZF	0.022 25	C183	RCUV1H681K	680P 50
C4	RCUV1H102MD	0.001 50	C83	ECEA1HK010B	1 50	C184	RCUV1E103MD	0.01 25
C5	RCUV1H102MD	0.001 50	C84	RCUV1E223ZF	0.022 25	C185	RCUV1E103MD	0.01 25
C6	RCUV1H102MD	0.001 50	C85	ECEA1CK470B	47 16	C301	ECQB1H223JZ3	0.022 50
C7	RCUV1E103MD	0.01 25	C86	RCUV1E223ZF	0.022 25	C302	ECEA1HK2R2B	2.2 50
C9	RCUV1H010CC	1P 50	C87	RCUV1E223ZF	0.022 25	C303	RCUV1H221K	220P 50
C10	RCUV1H150KC	15P 50	C88	RCUV1E333MD	0.033 25	C304	ECEA1HK010B	1 50
C12	RCUV1H150KC	15P 50	C89	RCUV1H030CC	3P 50	C305	RCUV1H221K	220P 50
C13	RCUV1H390KC	39P 50	C90	RCUV1H050CC	5P 50	C306	ECEA1HKND10B	1 50
C14	RCUV1H80KC	18P 50	C91	RCUV1E333MD	0.033 25	C307	RCUV1E103MD	0.01 25
C15	ECEA0JK220B	22 6.3	C92	RCUV1H221K	220P 50	C308	ECUV1E104MD	0.1 25
C16	RCUV1H470KC	47P 50	C93	RCUV1H472MD	0.0047 50	C309	ECEA1HK010B	1 50
C17	RCUV1E333MD	0.033 25	C94	RCUV1E223ZF	0.022 25	C310	ECEA1HK010B	1 50
C18	RCUV1E223ZF	0.022 25	C95	RCUV1H391K	390P 50	C311	ECQB1H223JZ3	0.022 50
C19	ECUV1E683MD	0.068 25	C96	RCUV1H102MD	0.001 50	C312	ECEA1CS102	1000 16
C20	RCUV1E223ZF	0.022 25	C97	RCUV1E103MD	0.01 25	C313	RCUV1H221K	220P 50
C21	RCUV1E333MD	0.033 25	C98	ECEA1CK100B	10 16	C314	ECEA1HK2R2B	2.2 50
C22	ECEA1HK010B	1 50	C99	RCUV1E103MD	0.01 25	C315	ECEA1HK010B	1 50
C23	ECEA1CK470B	47 16	C100	RCUV1H331K	330P 50	C316	RCUV1H221K	220P 50
C24	RCUV1E223MD	0.022 25	C101	ECEA0JK330B	33 6.3	C317	RCUV1E103MD	0.01 25
C25	RCUV1E223MD	0.022 25	C102	RCUV1E103MD	0.01 25	C318	ECUV1E104MD	0.1 25
C26	ECEA1EK4R7B	4.7 25	C103	RCUV1H471K	470P 50	C319	ECEA1HKND10B	1 50
C27	ECEA1HKR33	0.33 50	C104	RCUV1H391K	390P 50	C320	ECEA0JK101B	100 6.3
C28	RCUV1H101K	100P 50	C105	RCUV1E103MD	0.01 25	C321	ECEA1HK010B	1 50
C29	RCUV1E223ZF	0.022 25	C106	RCUV1E333MD	0.033 25	C322	ECEA1HK010B	1 50
C30	ECEA1CK470B	47 16	C107	ECEA1CK101B	100 16	C323	ECEA0JK221B	220 6.3
C31	RCUV1E223ZF	0.022 25	C108	RCUV1H102MD	0.001 50	C324	ECEA0JK470B	47 6.3
C32	ECEA1HKND10B	1 50	C109	ECEA1HKND10B	1 50	C325	ECEA1HKND10B	1 50
C33	ECEA1HK010B	1 50	C110	RCUV1E333MD	0.033 25	C326	ECEA1HKND10B	1 50
C34	RCUV1E223ZF	0.022 25	C111	ECEA0JK220B	22 6.3	C327	ECEA0JK101B	100 6.3
C35	ECEA1HKR22B	0.22 50	C112	ECSF1CE105E	1 16	C328	RCUV1E223MD	0.022 25
C36	ECEA1HK010B	1 50	C113	RCUV1H101K	100P 50	C329	RCUV1H102MD	0.001 50
C37	ECEA1HK010B	1 50	C114	RCUV1H471K	470P 50	C330	ECUV1E104MD	0.1 25
C38	RCUV1E103MD	0.01 25	C115	ECUV1E683MD	0.068 25	C331	ECEA1HK2R2B	2.2 50
C39	ECEA1HK010B	1 50	C116	RCUV1E333MD	0.033 25	C332	ECEA1HK010B	1 50
C40	RCUV1E103MD	0.01 25	C117	RCUV1E333MD	0.033 25	C333	RCUV1H103ZF	0.01 50
C41	RCUV1E103MD	0.01 25	C120	ECEA1CK101B	100 16	C334	ECQB1H103JZW	0.01 50
C42	RCUV1E223MD	0.022 25	C121	ECEA1CK101B	100 16	C335	ECEA1HKR22B	0.22 50
C43	RCUV1E333MD	0.033 25	C122	ECEA1EK3R3B	3.3 25	C336	RCUV1H391K	390P 50
C44	ECEA1EK4R7B	4.7 25	C124	ECEA1CK101B	100 16	C337	RCUV1E223MD	0.022 25
C46	ECEA1CS102	1000 16	C125	ECEA1EK3R3B	3.3 25	C338	ECUV1E473MD	0.047 25
C47	ECEA1AK220B	22 10	C126	ECEA1CK100B	10 16	C339	ECEA1CK101B	100 16
C48	RCUV1H332MD	0.0033 50	C127	RCUV1E223ZF	0.022 25	C340	RCUV1E103MD	0.01 25
C49	ECEA1HK010B	1 50	C128	RCUV1H681K	680P 50	C341	RCUV1H550KC	56P 50
C50	ECEA1HK010B	1 50	C129	RCUV1H681K	680P 50	C342	ECEA1CK100	10 16
C51	ECEA1CK100B	10 16	C130	ECEA1HK0R1B	0.1 50	C343	ECUV1E473MD	0.047 25
C52	ECEA1HK010B	1 50	C131	ECEA1HK0R1B	0.1 50	C344	ECEA1CK470B	47 16
C53	ECEA1HK010B	1 50	C132	ECEA0JK470B	47 6.3	C345	ECEA1HK010B	1 50
C54	ECEA1EK4R7B	4.7 25	C133	RCUV1H682MD	0.0068 50	C346	ECEA1CK100B	10 16
C55	ECEA1EK3R3B	3.3 25	C134	ECEA1CK470B	47 16	C347	ECUV1E473MD	0.047 25
C56	ECEA1HK010B	1 50	C135	RCUV1H682MD	0.0068 50	C348	ECEA1HK010B	1 50
C57	ECEA1HK010B	1 50	C136	ECEA0JK470B	47 6.3	C350	RCUV1H103ZF	0.01 50
C58	ECEA0JK330B	33 6.3	C139	ECEA1HK010B	1 50	C351	ECEA1CK100B	10 16
C59	RCUV1E223MD	0.022 25	C140	ECEA1HK010B	1 50	C352	ECEA1HK2R2B	2.2 50
C60	ECEA1CK100B	10 16	C141	ECEA1HK010B	1 50	C353	ECEA0JK470B	47 6.3
C61	ECEA1CK100B	10 16	C142	ECEA1CK470B	47 16	C354	ECEA1CK470B	47 16
C62	ECEA1AKA221	220 10	C150	ECEA1EK4R7B	4.7 25	C355	RCBS1C103NYY	0.01 16
C63	ECEA1HK010B	1 50	C151	ECEA1HK010B	1 50	C356	RCBS1C103NYY	0.01 16
C64	ECEA1HK010B	1 50	C160	ECEA1EK4R7B	4.7 25	C358	ECEA1AK330B	33 10
C65	RCUV1E223ZF	0.022 25	C161	RCUV1H102MD	0.001 50	C359	ECEA1HK2R2B	2.2 50
C66	RCUV1H390KC	39P 50	C162	ECQV1H474JZ	0.47 50	C360	RCUV1H103ZF	0.01 50
C67	RCUV1E223ZF	0.022 25	C163	ECEA1CK100B	10 16	C401	ECEA1AU221	220 10
C68	RCUV1E223ZF	0.022 25	C164	RCUV1E103MD	0.01 25	C402	ECEA1HK010B	1 50
C69	RCUV1E223ZF	0.022 25	C165	ECEA1HK0R1B	0.1 50	C403	ECEA1HK010B	1 50
C70	RCUV1H150KC	15P 50	C167	RCUV1H150KC	15P 50	C404	ECEA1HK010B	1 50
C71	ECQP2A471GZ	470P 100	C168	RCUV1H100KC	10P 50	C405	ECEA1HK010B	1 50
C72	RCUV1E103MD	0.01 25	C169	RCUV1E103MD	0.01 25	C406	ECEA1ASS471	470 10
C73	RCUV1E223ZF	0.022 25	C170	ECEA0JUZ22V	2200 6.3	C407	ECEA1ALJ471	470 10
C74	ECEA1CK100B	10 16	C171	ECEA0JK470B	47 6.3	C408	ECUV1E104MD	0.1 25
C75	ECEA1HKR47B	0.47 50	C172	RCUV1E333MD	0.033 25	C409	ECEA0JK220B	22 6.3
			C173	RCUV1H102MD	0.001 50	C410	RCUV1E473MD	0.047 25

Ref. No.	Part No.	Value.	Ref. No.	Part No.	Value.	Ref. No.	Part No.	Value.
C411	ECEA1AK220B	22 10	C436	ECEA0JU101B	100 6.3	C512	ECUV1H102ZF	0.001 50
C412	RCUV1E473MD	0.047 25	C437	ECUV1E333MD	0.033 25	C513	ECUV1H102ZF	0.001 50
C413	ECEA0JK220B	22 6.3	C438	RCUV1H102MD	0.001 50	C514	RCUV1H102ZF	0.001 50
C414	ECEA1AU471	470 10	C440	ECEA0JU101B	100 6.3	C515	ECUV1H102ZF	0.001 50
C415	ECUV1E104MD	0.1 25	C441	ECEA1CSS222Z	2200 16	C516	ECUV1H102ZF	0.001 50
C416	ECEA1CU221E	220 16	C443	ECUV1E104MD	0.1 25	C517	ECUV1H102ZF	0.001 50
C417	ECQV1H104JZ	0.1 50	C444	ECUV1E104MD	0.1 25	C518	ECUV1H102ZF	0.001 50
C418	ECQV1H104JZ	0.1 50	C445	ECUV1E663MD	0.068 25	C519	RCUV1H102ZF	0.001 50
C419	ECEA1CV221SE	220 16	C446	ECUV1E663MD	0.068 25	C520	ECUV1H102ZF	0.001 50
C420	ECEA0JU101B	100 6.3	C447	ECUV1E663MD	0.068 25	C521	ECUV1H102ZF	0.001 50
C421	ECUV1E333MD	0.033 25	C448	ECUV1E663MD	0.068 25	C522	ECUV1H102ZF	0.001 50
C422	RCUV1H102MD	0.001 50	C450	ECUV1E104MD	0.1 25	C523	ECUV1H102ZF	0.001 50
C424	ECEA0JU101B	100 6.3	C451	ECEA1EKN3R3B	3.3 25	C524	RCUV1H102ZF	0.001 50
C425	ECQB1H103JZ3	0.01 50	C501	ECEA1CV221SE	220 16	C525	ECUV1H102ZF	0.001 50
C426	ECEA1HK010B	1 50	C502	ECUV1H102ZF	0.001 50	C526	ECUV1H102ZF	0.001 50
C427	ECEA1HK010B	1 50	C503	RCUV1H102ZF	0.001 50	C528	ECUV1H102ZF	0.001 50
C428	ECEA1HK010B	1 50	C504	ECUV1H102ZF	0.001 50	C529	ECUV1H103MD	0.01 50
C429	ECEA1HK010B	1 50	C505	ECUV1H102ZF	0.001 50	C530	ECEA1CV221SE	220 16
C430	ECEA1AU471	470 10	C506	ECUV1H102ZF	0.001 50	C601	ECEA1ASS471	470 10
C431	ECEA1CV221SE	220 16	C507	ECUV1H102ZF	0.001 50	C602	ECEA1CK100B	10 16
C432	ECQV1H104JZ	0.1 50	C508	ECUV1H102ZF	0.001 50	C603	ECEA1CK101B	100 16
C433	ECQV1H104JZ	0.1 50	C509	ECUV1H102ZF	0.001 50	C604	ECEA1ASS471	470 10
C434	ECQB1H103JZ3	0.01 50	C510	ECUV1H102ZF	0.001 50	C605	RCUV1E103MD	0.01 25
C435	ECEA1CV221SE	220 16	C511	ECUV1H102ZF	0.001 50	C606	RCUV1E103MD	0.01 25
						C607	RCUV1E103MD	0.01 25
						C601	ECKD1H102MD	0.001 50

**CABINET PARTS LIST** (See Illustrations on pages 20~22)

Ref. No.	Part No.	Description	Ref. No.	Part No.	Description
CABINET AND CHASSIS			20-25	RJP6G18ZA	PLUG (6P)
1	RJE235ZB	CONNECTOR CORD ASS'Y	20-26	RUP2308ZAN	P.C.B
2	RUB525ZA	ARM	20-27	3JSA1500ZA	SOCKET ASS'Y
3	RUL1000ZA	BRACKET	21	RJS4L10Z	SOCKET
4	RUL1042ZA	ANGLE	22	RJS4L4Z	SOCKET (4P)
5	RUL1043ZA	ANGLE	23	RJS8L10ZA-X	SOCKET
6	RUC977ZA	SPRING	24	RJS8L4ZA-X	SOCKET
7	RMC350ZA	INSULATOR	25	RJT8072B-X	TERMINAL
8	XYN3+H12	SCREW	26	RJT825Z	TERMINAL
9	XTB3+10J	SCREW	27	2JSA-6	REED WIRE
10	XTB3+6F	SCREW	28	2JSA-7	REED WIRE
11	XTB3+8J	SCREW	29	2JSA-2	REED WIRE
12	1KEA1500AZA	ANGLE	30	2JSA-1	REED WIRE
13	XTB3+12J	SCREW	31	RJP11G4YA	PLUG
14	RHE5183ZA	SCREW	32	RJP12G18ZA	PLUG(12P)
15	RKM1070ZB	MAIN CASE ASS'Y	33	RJP2G17ZA	PLUG(2P)
16	RKF917ZA	CABINET PLATE	34	RJP30A13ZA	PLUG(30P)
17	RBN9004ZA-0	KNOB, VOL VOL-INT	35	RJP4G18ZA	PLUG (4P)
18	RBN9005ZA-0	KNOB, TONE ETC.	36	RJS5L4Z	SOCKET
19	RYPM1500AJHD	CASSETTE COVER ASS'Y	38	RJS163Z	SOCKET
19-1	RUM128ZA	SPRING	39	RJS2L3Z	SOCKET(2P)
19-2	RME458ZA	ANGLE	40	RJE200ZA	CORD
19-3	RDF3120ZA	SHAFT	42	RJT707Z	TERMINAL
19-4	XTV26+6JFZ	SCREW	43	XTB3+6F	SCREW
19-5	RHG2128ZA	RUBBER	44	RUB521ZA	ARM
19-6	RYQM1500AJHD	HOLDER	45	RUL978ZB	ANGLE
20	RYMM1500AJHD	UPPER CABINET	46	RUD90ZB	SPRING
20-1	RZEM1500AJHD	CHASSIS	47	RJP269Y	PLUG(2P)
20-2	RUQ80ZA	COIL SPRING	48	RJP5G18Z	PLUG(5P)
20-3	RDF3120ZA	SHAFT	49	RJP6G18ZA	PLUG (6P)
20-4	RDF3125ZA	SHAFT	50	RJP6G9YA	PLUG
20-5	RDF3139ZA	SHAFT STOPPER	51	RJP8G18Z	PLUG(8P)
20-6	RDF3141ZA	SHAFT	52	RJP9G18ZA	PLUG(9P)
20-7	XTB3+10J	SCREW	53	RJP9G27ZA	PLUG
20-8	RHG2127ZA	RUBBER	54	RMC1153ZA	SHIELD COVER
20-9	RHG2128ZA	RUBBER	55	XAMR001SA	NEON LAMP
20-10	RHG2136ZA	RUBBER	56	XAMR011SA	NEON LAMP
20-11	RHG225Z	RUBBER	58	RJP8G28ZA	PLUG
20-12	RHG5056ZA	RUBBER	59	RJE248ZA	CONNECTOR CORD ASS'Y
20-13	RHE5161ZA	SCREW	60	RUL1001ZA	ANGLE
20-14	RGL74ZA	LENS	61	RMR122ZA	ANGLE
20-15	RYEM1500AJHD	LENS	62	RMC1154ZA	SHIELD COVER
20-16	RBC1196ZA-0	BUTTON, FAST	63	RMC1156ZA	SHIELD COVER
20-17	RBC1197ZA-0	BUTTON, FAST	64	XTB3+6F	SCREW
20-18	RBC1198ZA-0	BUTTON, TAPE/RADIO	65	XNSSD	NUT
20-19	RBC1199ZA-0	BUTTON, HEAD SET/SP	66	RUB522ZA	SHAFT
20-20	RBC1200ZA-0	BUTTON, BAND	67	RUL1047ZA	LEVER
20-21	RBC1201ZA-0	BUTTON, CH	68	RDF3122ZA	SHAFT
20-22	RBC1203ZA-0	BUTTON, MEMORY	69	XUC15FY-V	E RING
20-23	RBC1293ZA-0	BUTTON, AMBIENCE	70	XTB3+6FFZ	SCREW
20-24	RBC9121ZA-0	BUTTON, STOP/EJECT	71	RHE5190ZA	SCREW
			72	XYN3+H15	SCREW
			73	XTB3+8F	SCREW

**MECHANISM PARTS LIST** (See illustrations on pages 23, 24)

Ref. No.	Part No.	Description	Ref. No.	Part No.	Description
MECHANISM			M77	RFS773ZA	SPRING
CASSETTE DECK			M78	RFS774ZA	SPRING
M1	RFU140ZA	MECHANISM CHASSIS	M79	RFS775ZA	SHAFT
M2	RFM130ZA	MOTOR ASS'Y	M80	RFD360ZA	TA PLATE
M3	RFG114ZA	MAIN GEAR	M82	RFD361ZA	SW BRACKET
M5	RFE440ZA	PLATE ASS'Y	M83	RFD362ZA	ANGLE
M6	RFS761ZA	SPRING	M84	RFS776ZA	SPRING
M7	RFE441ZA	MAIN PLATE	M85	RFS777ZA	SPRING
M8	RFR50ZA	PINCH ROLLER ARM ASS'Y	M86	RFS778ZA	SPRING
M9	RFE442ZA	ANGLE	M87	RFY839ZA	LIFT UP LEVER
M10	RFE443ZA	LOCK PLATE ASS'Y	M88	RFD363ZA	FR BRACKET ASS'Y
M11	RFS762ZA	LOCK SP	M89	RFY847ZA	REW LEVER
M12	RFE444ZA	ANGLE	M90	RFY841ZA	FF LEVER
M13	RFE445ZA	COIL SPRING	M91	RFD364ZA	PC PLATE
M14	RFQ54ZA	PULLEY	M92	RFS779ZA	SPRING
M15	RFS763ZA	SPRING	M93	RFE449ZA	ANGLE
M16	RFE446ZA	SCREW	M94	RFD365ZA	PE PLATE ASS'Y
M17	RFP22ZA	COIL ASS'Y	M95	RFS780ZA	SPRING
M18	RFE447ZA	CORE	M96	RFS781ZA	SPRING
M19	RFX186ZA	PL BRACKET	M97	RFE450ZA	BACK SLIDER
M20	RFT21ZA	P.C.B W/S.W	M98	RFD366ZA	CD PLATE
M21	RFD369ZA	ANGLE	M99	RFS782ZA	SPRING
M22	RFD340ZA	SLIDE PLATE	M100	RFE451ZA	CASSETTE CASE
M23	RFD341ZA	ANGLE	M101	RFD372ZA	PLATE
M24	RFS764ZA	SPRING	M102	RFS783ZA	SPRING
M25	RFY836ZA	PINCH ROLLER ARM ASS'Y	M103	RF151ZA	RUBBER SPACER
M26	RFD342ZA	PULL PLATE	M104	RFX189ZA	SPACER
M27	RFD343ZA	PLATE	M106	RF152ZA	FELT
M28	RFD344ZA	ANGLE	M108	RFY849ZA	EJECT LEVER
M29	RFQ55ZA	PULLEY	M200	RFE468ZA	SCREW
M30	RFD345ZA	HEAD PANEL ASS'Y	M201	RFE452ZA	SCREW
M31	RFE448ZA	TAPE GUIDE	M202	RFE453ZA	SCREW
M32	RFD346ZA	HEAD SP PLATE	M203	RFE454ZA	SCREW
M33	RJH4C58G2AA	HEAD	M204	RFE455ZA	SCREW
M34	RFD347ZA	ANGLE	M205	RFE456ZA	SCREW
M35	RFS785ZA	PINCH ROLLER SP	M206	RFE457ZA	SCREW
M36	RFS786ZA	SPRING	M208	RFE458ZA	SCREW
M37	RFF59ZA	FLYWHEEL ASS'Y	M209	RFE459ZA	SCREW
M39	RFB96ZA	MAIN BELT	M210	RFE460ZA	SCREW
M40	RFD348ZA	MG PLATE ASS'Y	M211	RFE91Z	SCREW
M41	RFD349ZA	FG PLATE ASS'Y	M212	RFN201ZA	WASHER
M42	RFD350ZA	RG PLATE ASS'Y	M213	RFE461ZA	SCREW
M43	RFS767ZA	FR GEAR PLATE SP	M214	RFN191ZA	WASHER
M44	RFG115ZA	FF GEAR	M215	RFN192ZA	WASHER
M45	RFD351ZA	ED PLATE	M216	RFN193ZA	WASHER
M46	RFD352ZA	ED PLATE	M217	RFN194ZA	WASHER
M47	RFY837ZA	LEVER	M218	RFN195ZA	WASHER
M48	RFD353ZA	TG PLATE ASS'Y	M219	RFN196ZA	WASHER
M49	RFD354ZA	TG PLATE ASS'Y	M220	RFE469ZA	SCREW
M50	RFS788ZA	TG PLATE SPRING	M221	RFN197ZA	WASHER
M51	RFG116ZA	T GEAR	M222	RFN198ZA	WASHER
M52	RFG125ZA	FT-GEAR	M223	RFN199ZA	WASHER
M53	RFK22ZA	FR CLUTCH ASS'Y	M224	RFN200ZA	WASHER
M54	RFG118ZA	GEAR	M225	RFE463ZA	E RING
M55	RFG119ZA	GEAR	M227	RFE464ZA	E RING
M56	RFG120ZA	DT GEAR	M228	RFE465ZA	E RING
M58	RFD355ZA	ES PLATE	M229	RFE466ZA	E RING
M59	RFG121ZA	GEAR	M230	RFE467ZA	E RING
M60	RFG122ZA	CAM GEAR	M231	RJA9040ZA	CHASSIS
M62	RFS769ZA	SPRING	M232	RUB518ZA	ARM
M63	RFY838ZA	LEVER	M233	RUB519ZA	ARM
M64	RFS770ZA	ED SPRING	M234	RUB520ZA	ARM
M65	RFX167ZA	SPACER	M235	RUB9028ZA	LEVER
M66	RFJ81ZA	REEL TABLE	M236	RUD88ZA	COIL SPRING
M67	RFX188ZA	SPACER	M237	RUD89ZA	COIL SPRING
M68	RFG123ZA	GEAR	M238	XTB346F	SCREW
M70	RFD357ZA	KF BRACKET ASS'Y	M240	RHR1354ZA	HOLDER
M71	RFT22ZA	P.C.B W/S.W	M246	RHE5160ZA	SCREW
M72	RFD358ZA	ANGLE	M247	RHG9009ZA	RUBBER SPACER
M73	RFS771ZA	SPRING	M249	XNG4B	NUT
M74	RFS772ZA	SPRING	M250	XWA4B	WASHER
M75	RFG126ZA	CAM GEAR	M251	RJP8628ZA	PLUG
M76	RFD359ZA	KF PLATE ASS'Y			



**ELECTRICAL PARTS LIST**

Ref. No.	Part No.	Description	Ref. No.	Part No.	Description
<b>INTEGRATED CIRCUITS</b>			Q314	UN2214TW	TRANSISTOR
IC1	LA1175	I.C. FM FRONT END	Q315	UB2214TX	TRANSISTOR
IC2	RV1LA1140	I.C. FM IF & DET	Q401	2SC1622D17TW	TRANSISTOR
IC3	STK3400A	I.C. FM NOISE BRANKER	Q402	2SC1622D17TW	TRANSISTOR
IC4	RV1BA6133	I.C. AMBIENCE	Q403	2SD601R	TRANSISTOR
IC5	LA1135	I.C. AM TUNER	Q404	2SD601R	TRANSISTOR
IC6	HA12429	I.C. AM NOISE BRANKER	Q405	2SD601R	TRANSISTOR
IC7	RV1UPC1228H	I.C. TAPE EQ AMP	Q406	2SD601R	TRANSISTOR
IC9	UPD1714GA929	I.C. PLL & CONT	Q407	2SB709ARTW	TRANSISTOR
IC301	MN4066B	I.C. SIGNAL SELECTOR	Q408	2SD601R	TRANSISTOR
IC302	RV1UPC1228H	I.C. TAPE EQ AMP	Q409	2SD601R	TRANSISTOR
IC303	RV1TC4529BP	I.C. FLIP FLOP	Q410	2SB1144S	TRANSISTOR
IC304	M51203TL	I.C. MUTE CONT	Q601	2SA1096R	TRANSISTOR
IC401	RV1TA7230P	I.C. POWER AMP	Q602	2SD601RTX	TRANSISTOR
IC402	TA7295P	I.C. POWER AMP	Q603	2SC2497R	TRANSISTOR
IC403	TA7295P	I.C. POWER AMP	<b>DIODES</b>		
IC601	RV1TC4011BP	I.C. NAND GATE	D1	RVD1SV103	DIODE
<b>TRANSISTORS</b>			D2	1SV99	DIODE
Q1	3SK74L	TRANSISTOR	D3	1SV99	DIODE
Q3	2SD601R	TRANSISTOR	D4	RVD1SV103	DIODE
Q4	2SD601R	TRANSISTOR	D5	RVD1SV103	DIODE
Q5	2SD601R	TRANSISTOR	D6	RVD1SV103	DIODE
Q6	2SD601R	TRANSISTOR	D7	RYDKB265G	DIODE
Q7	2SD601R	TRANSISTOR	D8	RYDKB265G	DIODE
Q8	2SD601R	TRANSISTOR	D9	MA165	DIODE
Q9	UN2214TW	TRANSISTOR	D12	MA151WKTW	DIODE
Q10	2SK160K4TW	TRANSISTOR	D13	RYDKV1235Z2	DIODE
Q11	2SK184GR	TRANSISTOR	D14	MA153TW	DIODE
Q12	2SK184GR	TRANSISTOR	D17	SM-1A-12	DIODE
Q13	2SD601R	TRANSISTOR	D19	MA151WATW	DIODE
Q14	2SD601R	TRANSISTOR	D20	MA4120MTA	DIODE
Q15	2SD601R	TRANSISTOR	D21	MA4110MTA	DIODE
Q16	2SD601R	TRANSISTOR	D22	MA151WATW	DIODE
Q17	2SD601R	TRANSISTOR	D23	MA4062M	DIODE
Q18	2SC2295B	TRANSISTOR	D24	MA151WKTW	DIODE
Q19	2SC2497R	TRANSISTOR	D25	MA4056M	DIODE
Q22	2SD601R	TRANSISTOR	D26	MA165	DIODE
Q23	2SD601R	TRANSISTOR	D27	MA165	DIODE
Q25	2SD601R	TRANSISTOR	D29	MA165	DIODE
Q27	2SD601R	TRANSISTOR	D30	MA165	DIODE
Q28	2SD596DV2TW	TRANSISTOR	D31	MA165	DIODE
Q29	UN2124TW	TRANSISTOR	D32	MA4047MTA	DIODE
Q30	2SC1384	TRANSISTOR	D33	MA165	DIODE
Q31	2SD601R	TRANSISTOR	D34	MA151WKTW	DIODE
Q32	2SC1384	TRANSISTOR	D301	MA165	DIODE
Q33	2SA684R	TRANSISTOR	D302	MA165	DIODE
Q34	2SD601R	TRANSISTOR	D303	MA4051M	DIODE
Q35	2SC1384	TRANSISTOR	D304	MA153	DIODE
Q36	2SK160K4TW	TRANSISTOR	D305	MA153	DIODE
Q37	2SD601R	TRANSISTOR	D306	MA4062M	DIODE
Q38	2SB709RTW	TRANSISTOR	D308	MA151WATW	DIODE
Q39	2SB709RTW	TRANSISTOR	D309	MA151WK	DIODE
Q40	2SB709RTW	TRANSISTOR	D310	MA165	DIODE
Q41	2SD601STW	TRANSISTOR	D312	MA4100M	DIODE
Q47	RVTFMG5TX	TRANSISTOR	D313	MA151WATW	DIODE
Q48	RVTFMG5TX	TRANSISTOR	D314	MA152K	DIODE
Q49	2SD601R	TRANSISTOR	D405	MA151WKTW	DIODE
Q50	2SD601R	TRANSISTOR	D501	RYDDB15TC	DIODE
Q51	2SC2404CTW	TRANSISTOR	D601	SM-1A-12	DIODE
Q301	2SC1622D17TW	TRANSISTOR	D602	MA4110MTA	DIODE
Q302	2SD601RTX	TRANSISTOR	D603	MA165	DIODE
Q303	2SD601R	TRANSISTOR	D604	SM-1A-12	DIODE
Q304	2SD601R	TRANSISTOR	<b>VARIABLE RESISTORS</b>		
Q305	2SC1622D17TW	TRANSISTOR	VR1	EVND1A000B14	V.R. FM SEPARATION
Q306	2SD601RTX	TRANSISTOR	VR301	EVK9QB014B15	V.R. VOLUME
Q307	2SD601RTX	TRANSISTOR	VR302	EVK9QA014C23	V.R. AUTO VOLUME
Q308	2SK332D	TRANSISTOR	VR303	EVK9QA014GA5	V.R. TONE
Q309	2SD601RTX	TRANSISTOR	VR304	EVND1A000B53	V.R. AVC GAIN
Q310	2SD601RTX	TRANSISTOR	VR305	EVK7QB014B24	V.R. INTER COM MIC
Q311	2SD601R	TRANSISTOR	VR306	EVK4QA014B24	V.R. MUTE LEVEL

Ref. No.	Part No.	Description	Ref. No.	Part No.	Description
<b>VARIABLE CAPACITORS</b>			T4	RLA2A6-T	COIL
CT1	RCVT220F	TRIMMER	T5	RLA2A7-T	COIL
CT2	RCVT220F	TRIMMER	T6	RLI2A29	I.F.TRANSFORMER
CT3	RCVT220F	TRIMMER	T7	RLI2A30	I.F.TRANSFORMER
CT4	RCVT220F	TRIMMER	T8	RLI2A16	I.F.TRANSFORMER
<b>THERMISTORS AND VARISTORS</b>			T9	RLI4A41-T	FREQUENCY TRANSFORMER
TH301	RRT103	THERMISTOR	<b>FILTERS</b>		
<b>COILS AND TRANSFORMERS</b>			CF1	RVF107WAZ	CERAMIC FILTER
L1	RLA4N19A-0	COIL	CF2	RVF107WAZ	CERAMIC FILTER
L2	RLQZP150KT-Y	COIL	CF3	NCRZ450C4N7W	COMBINATION PART
L4	RLA4N20A-0	COIL	CF4	RVFCFMS450B	CERAMIC FILTER
L5	RLA4N21A-0	COIL	<b>LAMPS</b>		
L6	RLQ4N235A-0	COIL	NE1	XANR13T33	NEON LAMP
L8	RLQZP4R7KT-Y	COIL	<b>SWITCHES</b>		
L501	RLT667A-1	CH TRANSFORMER	S201	RFT21ZA	P.C.B W/S.W. FWD/REV
L601	RLT6D1A	COIL	S202	RFT22ZA	P.C.B W/S.W. FWD/REV
T1	RLI4A40-Z	COIL	S204	RFA84ZA	SW. MUTE
T2	RLI4A24	I.F.TRANSFORMER	<b>OTHERS</b>		
T3	RLQ2A26-T	COIL	X1	RVBCSB456F15	CERAMIC FILTER
			X2	RVCE4500NZN	CRYSTAL OSCILLATOR

**BLANK PAGE**