

Stop Switch Mounting Guidelines

Note: This document only contains information for the stop switch installation.
For full and detailed wiring information see the superwind owner's manual.

General Information:

In stop-position the switch connects the wires (+) and (-) of your superwind 350 to short-circuit its generator to effect substantial reduction of the rotor speed. In stop-position the switch also disconnects the shorted generator from the battery circuit.

Mounting:

The stop switch is only designed for indoor panel mounting. For easy adaption to panels of up to 22 mm thickness the shaft is adjustable.

Before installing the switch adjust the shaft to the length required and fix it by means of the screw (see picture).

Note: For very thin panels it might be necessary to cut off the screw's head afterwards for proper mounting.

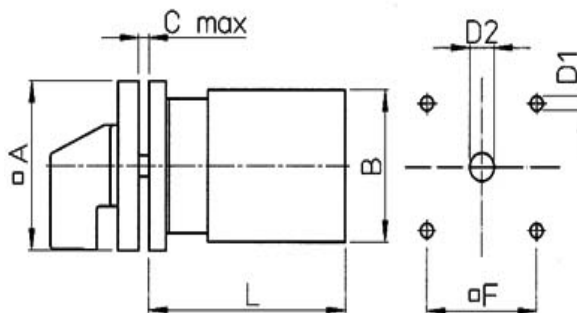

Dimensions [mm]:

A	48
B	42
Cmax	22
D1	4.1
D2	20
F	36
L	55

Electrical Connection:

Warning: Any electrical work may be accomplished only by authorized and skilled persons !

During any connection work, the related electrical circuit must be disconnected from the battery terminals !

For optimum brake efficiency the wires between the superwind generator and the stop switch should be as short as possible.
For appropriate conductor cross-sections see owner's manual.

Important: It is obligatory to install a fuse of 40 A in the (+) wire between the stop switch and the battery !

No fuse must be installed between the stop switch and the superwind generator !

The switch terminals are used as follows:

wire	terminal no.
superwind generator (+)	2
superwind generator (-)	6
battery (+) [only if the optional marine charge regulator is installed: regulator input (+)]	3
battery (-) [only if the optional marine charge regulator is installed: regulator input (-)]	7
no connection allowed	4
no connection allowed	8

Note: the bridge between terminals 1 and 5 must not be removed !

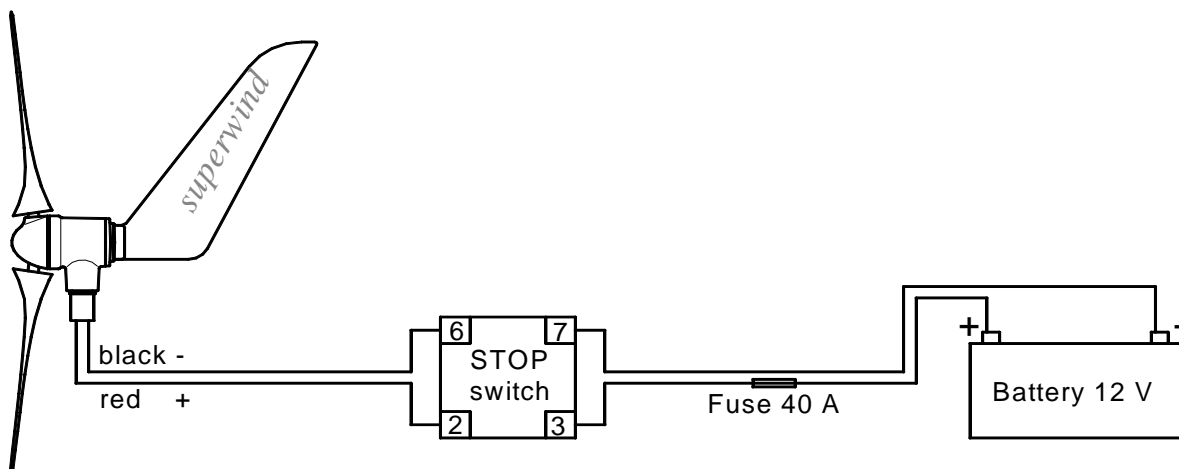

Wiring scheme shows connection without marine charge regulator.