

SIM RIG GT

Product Manual

Introduction

Thank you for purchasing the Heusinkveld Engineering Sim Rig GT! This is a compact, clean, adjustable and very stiff simulator frame for a GT-style simracing experience. Please take your time to read this manual to make sure your cockpit is put together as solid as we intended it to be.

The main features of the frame are:

- Extremely stiff construction with almost no flex and wobble.
- GT 'low' seating position for drivers between 1.5 and 2 meter (5ft to 6ft 6in).
- Fits Fanatec CSW, SimSteering (AKM 52-53-54), Accuforce, OSW Lenze and OSW Mige motors.
- Fits Heusinkveld Engineering Sim Pedals Pro and Sim Pedals Ultimate.
- Adjustable heel support.
- Fits Heusinkveld Engineering Sim Shifter Sequential.
- Fits Heusinkveld Engineering Sim Handbrake.
- Fits most side mount racing seats up to 435mm mounting width, universal brackets included.
- Fits up to three 16:9 monitors up to 28" or a single 21:9 monitor up to 35".
- 75mm and 100mm VESA mounts included.
- Side screens allowing for more than 90 degrees adjustable 'toe in'.
- Adjustable distance between monitors and driver's eyes: Monitors can be positioned directly behind the steering wheel or up to 30cm further away.
- Adjustability is a key word at Heusinkveld Engineering, so almost every component can be positioned where you want it to be.

The frame is meant for serious simracers or motorsport professionals. While the seating position is adjustable, it is not possible to adjust it with a driver in the seat. Adjusting the forward-backward position of the seat will take you a minute to do. If you want to adjust for length, it is easier and faster to adjust the pedal mounting plate.

We chose installation stiffness above lightning fast adjustments as we found regular seat sliders flex considerably at very high braking forces. If you have to adjust the seating position every 10 minutes, this may not be the ideal simulator frame for you.

Before we start

The Sim Rig GT consists of 2 kits: The powder coated Bracket Kit and the aluminium Profiles Kit. You have either purchased:

1. The Bracket Kit and the Profiles Kit through Heusinkveld Engineering.
2. The Bracket Kit through Heusinkveld Engineering. You chose to source the aluminium Profiles Kit at a different vendor.

You will need all the parts from both the Bracket Kit AND the Profiles Kit in order to assemble the Sim Rig GT frame. If you've chosen option 2, you not only have to source the aluminium profiles yourself, but also various fasteners and mounting accessories. Consult the next few pages in this manual for a full parts list of both kits.

This manual will now continue, assuming you either chose option 1, or sourced all the parts from the Profiles Kit (option 2) yourself in addition to the Bracket Kit.

What is included

This schematic helps you to identify the large parts of your Sim Rig GT.

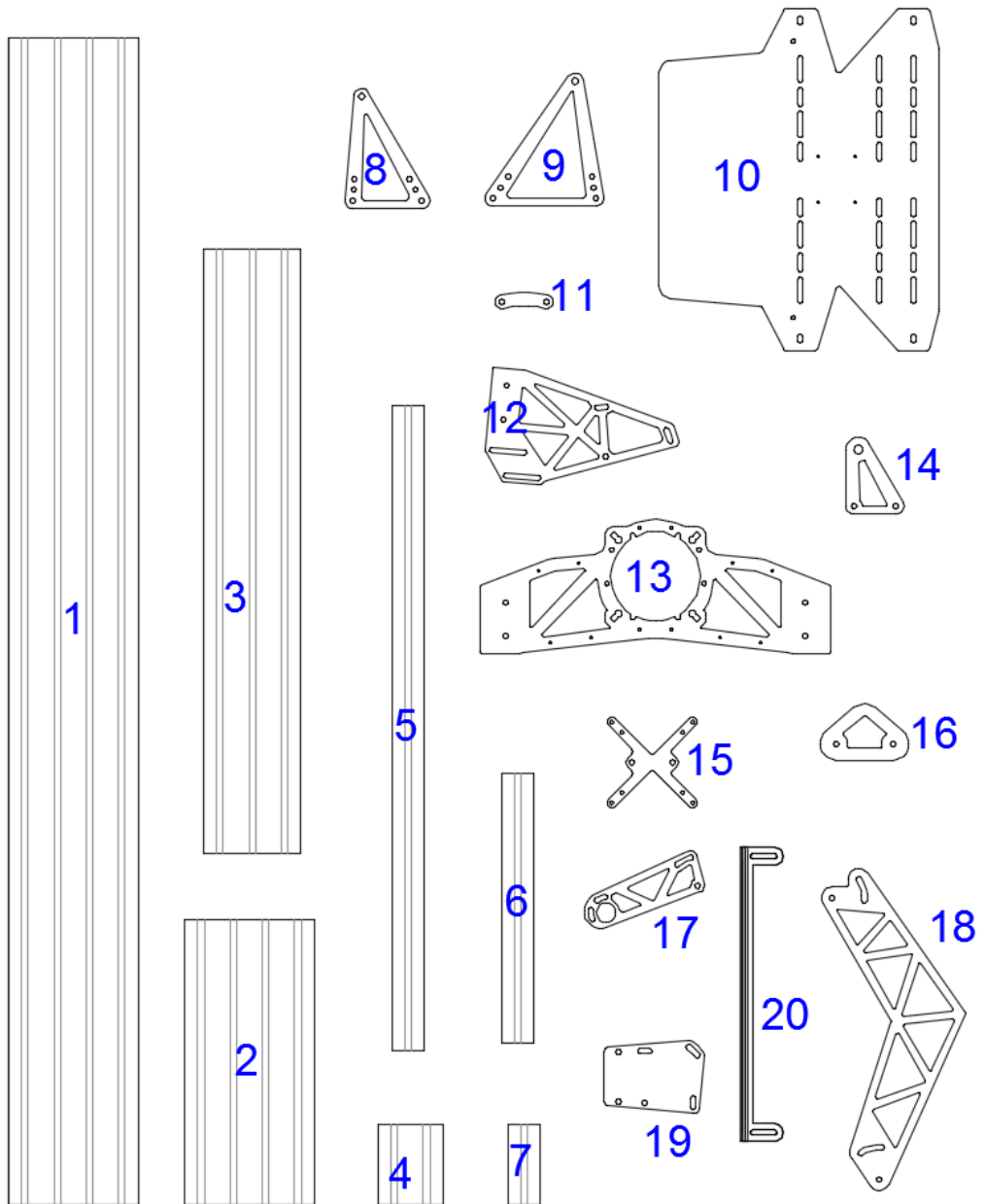

Parts list - large parts

The Sim Rig GT product consists of the parts mentioned in these parts lists.

The table below lists the large parts of your Sim Rig GT. The first column tells you in which kit the part can be found. The number in the second column corresponds with the large parts schematic on the previous page.

Kit	Nr	Qty	Description
Profiles Kit	1	2	160x40 1495mm length aluminium profile, main simulator beams
Profiles Kit	2	2	160x40 355mm length aluminium profile, lateral main frame beams
Profiles Kit	3	2	120x40 750mm length aluminium profile, vertical wheel / monitor beams
Profiles Kit	4	1	80x40 100mm length aluminium profile, handbrake spacer
Profiles Kit	5	1	40x40 800mm length aluminium profile, monitor rack middle monitor mount
Profiles Kit	6	2	40x40 360mm length aluminium profile, monitor rack outer monitors mount
Profiles Kit	7	2	40x40 100mm length aluminium profile, monitor rack to brackets mount
Bracket Kit	8	2	10mm powder coated rear (smaller) seat bracket
Bracket Kit	9	2	10mm powder coated front (taller) seat bracket
Bracket Kit	10	1	15mm powder coated pedal plate
Bracket Kit	11	2	10mm powder coated Fanatec CSW spacers
Bracket Kit	12	2	10mm powder coated wheel mount side brackets
Bracket Kit	13	1	10mm powder coated wheel mount bracket
Bracket Kit	14	4	10mm powder coated simulator feet
Bracket Kit	15	3	10mm powder coated 100mm and 75mm VESA monitor brackets
Bracket Kit	16	4	10mm powder coated outer monitor swing arm brackets
Bracket Kit	17	1	10mm powder coated sequential shifter bracket
Bracket Kit	18	2	10mm powder coated monitor frame uprights
Bracket Kit	19	1	10mm powder coated handbrake mounting plate
Bracket Kit	20	1	3mm stainless steel heel plate

Parts list - small parts

The table below lists the small parts of your Sim Rig GT. The first column tells you in which kit the part can be found.

Kit	Part	Qty	Description
Profiles Kit	Plastic Cover Caps	24	Plastic end caps for all aluminium profiles and corner brackets
Profiles Kit	Corner bracket	30	90 angle bracket with M8 bolt and nut and plastic cover bracket
Profiles Kit	M6 T nut guided	100	1 bag of M6 T nuts for mounting brackets to aluminium profiles
Profiles Kit	Connection plate	3	80x40mm steel plate with screws and nuts for handbrake mount
Profiles Kit	M6x30 bolt	35	Long bolt for mounting pedals (12), shifter (2)
Profiles Kit	M6x25 bolt	78	Medium bolt for mounting brackets to frame
Profiles Kit	M6x20 bolt	20	Short bolt for VESA brackets to frame,heel plate to pedal plate
Profiles Kit	M4x30 bolt	25	Long monitor mount bolts
Profiles Kit	M4x18 bolt	25	Short monitor mount bolts
Profiles Kit	Cable binding block	10	'Twist in' cable management clips
Bracket Kit	70mm feet	4	Four feet for the simulator to stand on
Bracket Kit	M10 washer + nut	10	Nuts and washers to mount feet to brackets (8 of each needed)
Bracket Kit	M6x30 locking lever	6	With integrated bolt - Pedal plate to frame
Bracket Kit	M6 nut	200	Plenty of nuts to mount pedals, wheel brackets etc
Bracket Kit	M6x18x1.6 washer	200	Plenty of washers to use with M6 bolts
Bracket Kit	M4 washers	500	Plenty of washers to use as monitor bolt spacers
Bracket Kit	M8x35 bolt	12	Seat brackets / OSW / SimSteering motors
Bracket Kit	M8 nut	4	OSW / SimSteering motors
Bracket Kit	M8 washer	40	Seat brackets / OSW / Simsteering motors
Bracket Kit	M8 locking lever	10	Without integrated bolt - Seat brackets
Bracket Kit	M5x40 bolt	4	AccuForce mount
Bracket Kit	M5 washer	4	AccuForce mount
Bracket Kit	M8 bolt lock plate	8	Seat brackets
Bracket Kit	cable ties	107	Long cable ties for cable management

What is NOT included

We include a lot of accessories but you may need to visit the local hardware store for certain parts, depending on your seat and monitor choice. We also require you to use your own tools, as these are not supplied.

Seat

There is a great variety in racing seats available. We often go with the Cobra Imola, available in two sizes. The regular one fits up to about European jeans size 34 for a very 'snug' fit, the GT version is 25mm (1") wider for a good amount of extra room.

The mounting holes in the Sim Rig GT seat brackets are 8,5mm. Almost all side mounting race seats should fit on our universal bracket solution. We can't guarantee that all seats will fit though!

The main factor is the mounting width of the seat. The brackets are spaced out 435mm. You can often find seat dimensions on the manufacturer website. These are the dimensions for the Cobra Imola seats (both versions):

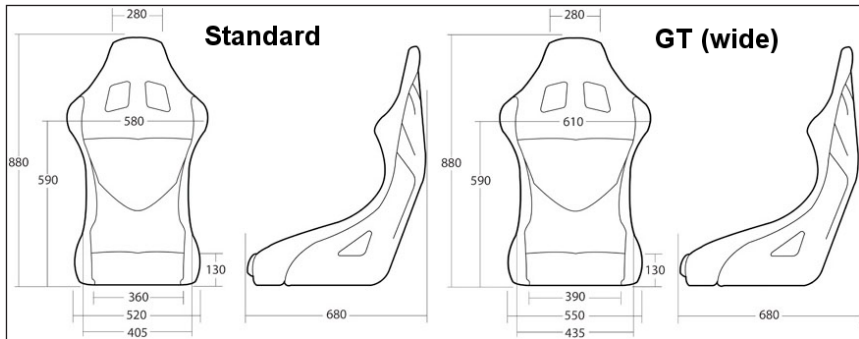

The standard seat has a width of 405mm and the wide GT version 435mm. The wide version has the same width as the frame, so it should fit with minimal spacers. The narrow seat will require a spacer stack of 30mm to fit, as the 405mm seat has to mate with the 435mm spaced seat brackets.

Depending on the seat you choose, you need to source your own mounting bolts, washers and spacers. Also beware that not all seats are created equal. We have seen considerable tolerances on the positioning of the side mounting holes and seat width for identical types of seats.

Monitors

Another situation we can't fully cover is mounting your monitors. We include two sizes of M4 bolt, which is the most common thread size used. We also include a box of washers that can be used as spacers to make sure most monitors will fit. However, on certain models it may be required to get a different type or length of bolt for mounting your screens.

General tools required

To assemble the cockpit ideally you have a work bench to avoid working on the floor, although that is always an option. If you use a normal table, be very careful as a scratch is easy to make! These tools are needed:

- 5mm allen key for M6 bolts, M8 countersunk bolts and M8 dome bolts.
- 10mm wrench for M6 nuts.
- 2x 17mm wrench for M10 nuts for the simulator feet.
- 3mm allen key for M4 monitor bolts.
- Rubber hammer to mount the profile end caps.
- Flat screwdriver to break off 90 degree bracket lips.

Wheel specific tools required

Bolts and nuts for all supported wheels are included with the Sim Rig GT. These tools are needed:

- Accuforce mounting: M5x40 bolts which requires a 4mm allen key.
- Fanatec CSW mounting: M6x30 bolts which requires a 5mm allen key.
- SimSteering / OSW mounting (Kollmorgen AKM-5x, Lenze & Mige motors): M8x35 bolts and nuts which require a 13 mm wrench.

Construction essentials

To make sure the powder coated brackets are tightly secured to the aluminium profiles, 2 washers have to be used between the bolt head and the bracket.

In the left picture you can see what happens when only one washer is used. The bolt 'bottoms out' in the aluminium profile and the black powder coated bracket isn't secured against the aluminium profile.

In the right picture using 2 washers, the powder coated bracket will be tightly fixed against the aluminium profile. This is the correct way and it also applies to the locking levers (unless specified otherwise). We always want to clamp the brackets against the beams, not allowing them to wobble as they would with only 1 washer.

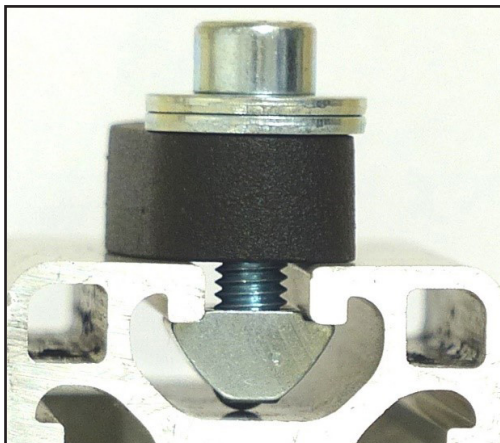
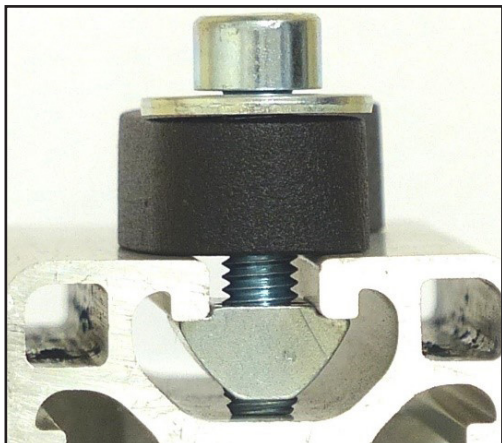

10mm thick brackets need M6x25 bolts, unless specified otherwise.

The locking levers are ideal for tool-less adjustments. They are used on the pedal plate and seat brackets.

Pulling up on the lever makes them rotate freely, so you can adjust the handle position without tightening or loosening the screw.

Letting go, the spring loaded lever will return in 'locked' position and you can now tighten or loosen the connection.

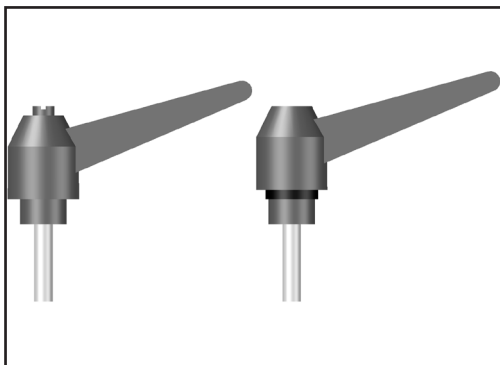

The hard plastic cable binding blocks can be twisted to secure them in the slots of the aluminium profile.

Cable ties can then be inserted and used to neatly rout the cables.

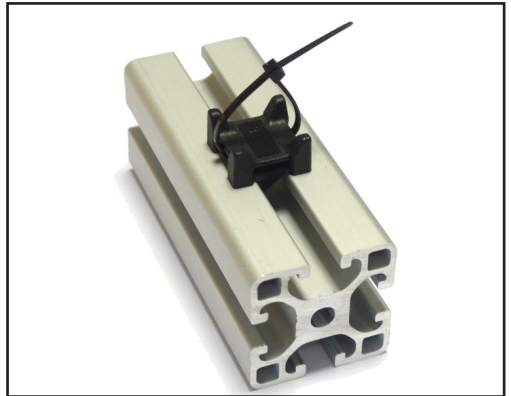

The VESA monitor brackets most likely require spacers because of the M6 bolt heads that stick out after mounting the VESA bracket to the aluminium profile.

We include 2 lengths of bolt, and you can make a stack of washers to act as spacers. This method should make most monitors fit.

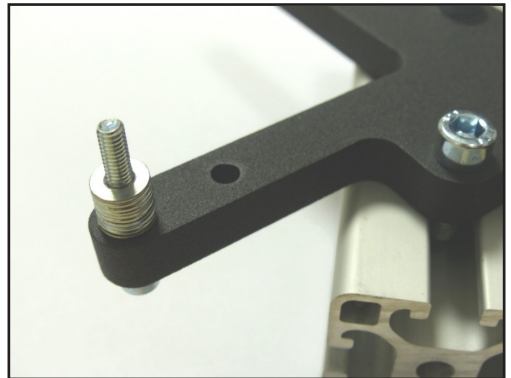

The 90 degree angle brackets have small lips on them which, if needed, can be broken off easily with a flat screwdriver.

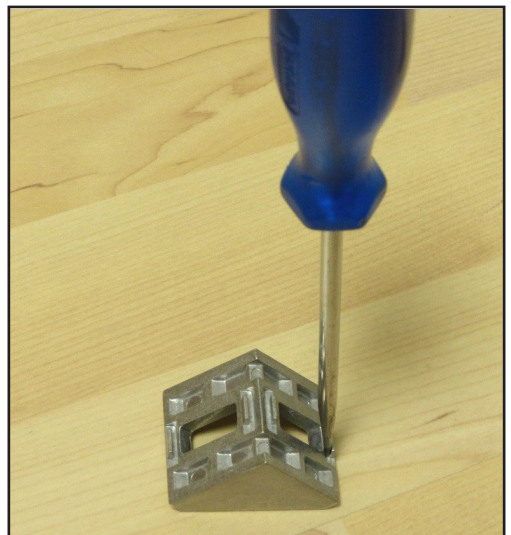

A glimpse at the end result

This is the bare frame in *3D front view* which should appear after you've followed this guide closely.

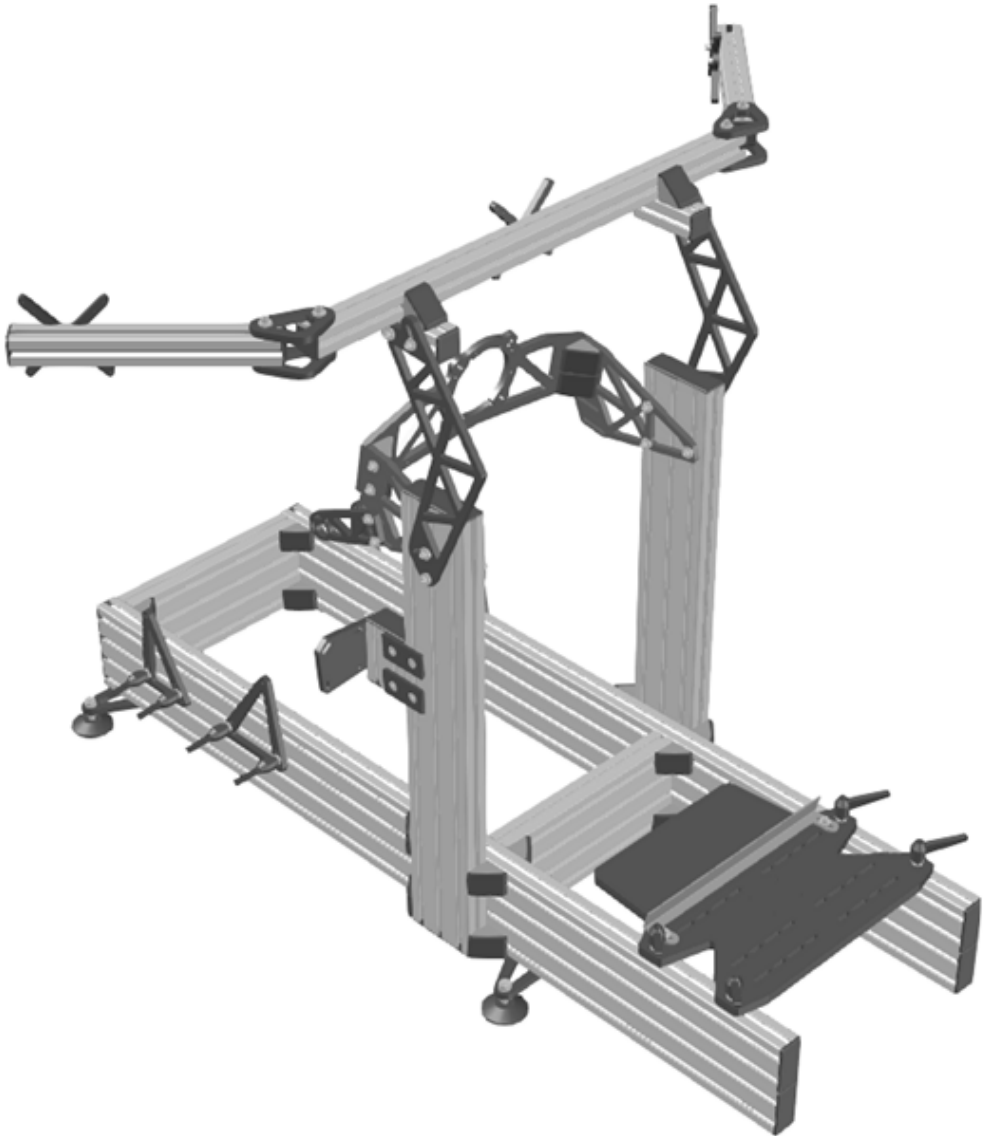

3D rear view

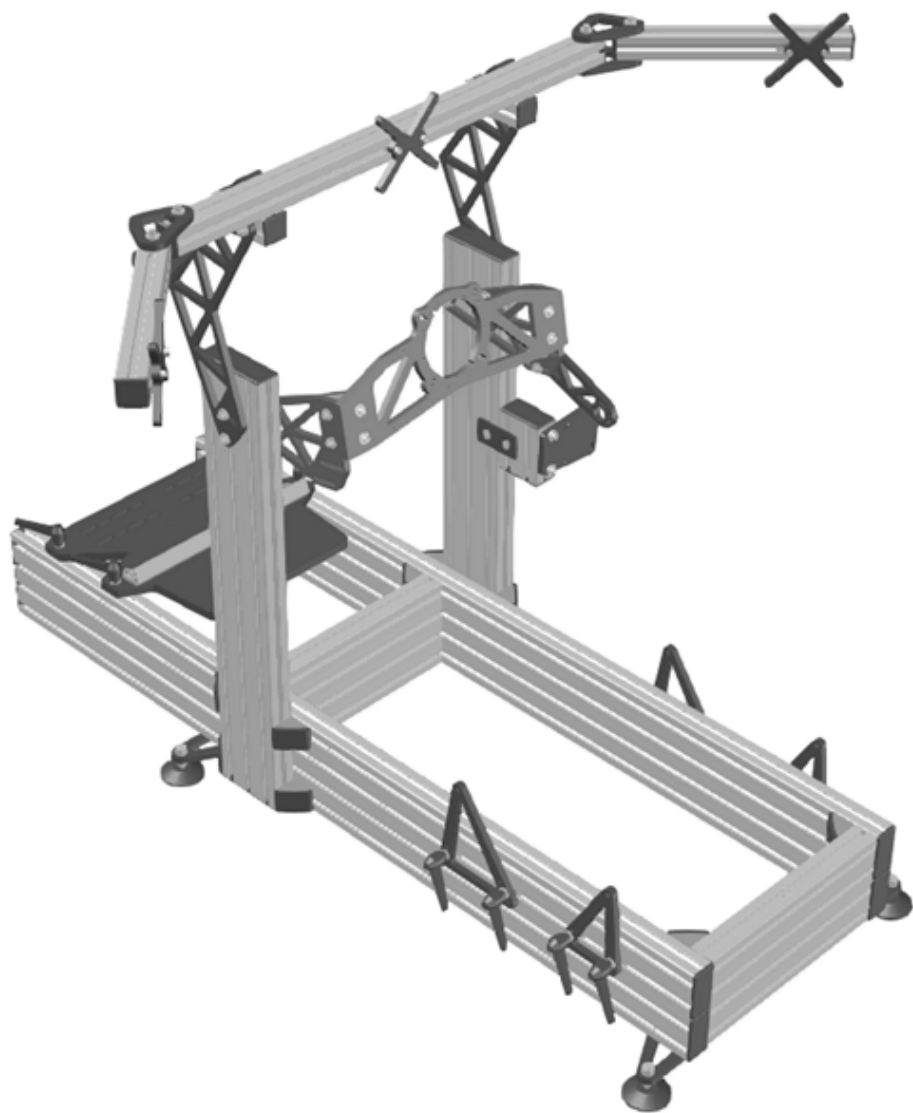

Top view

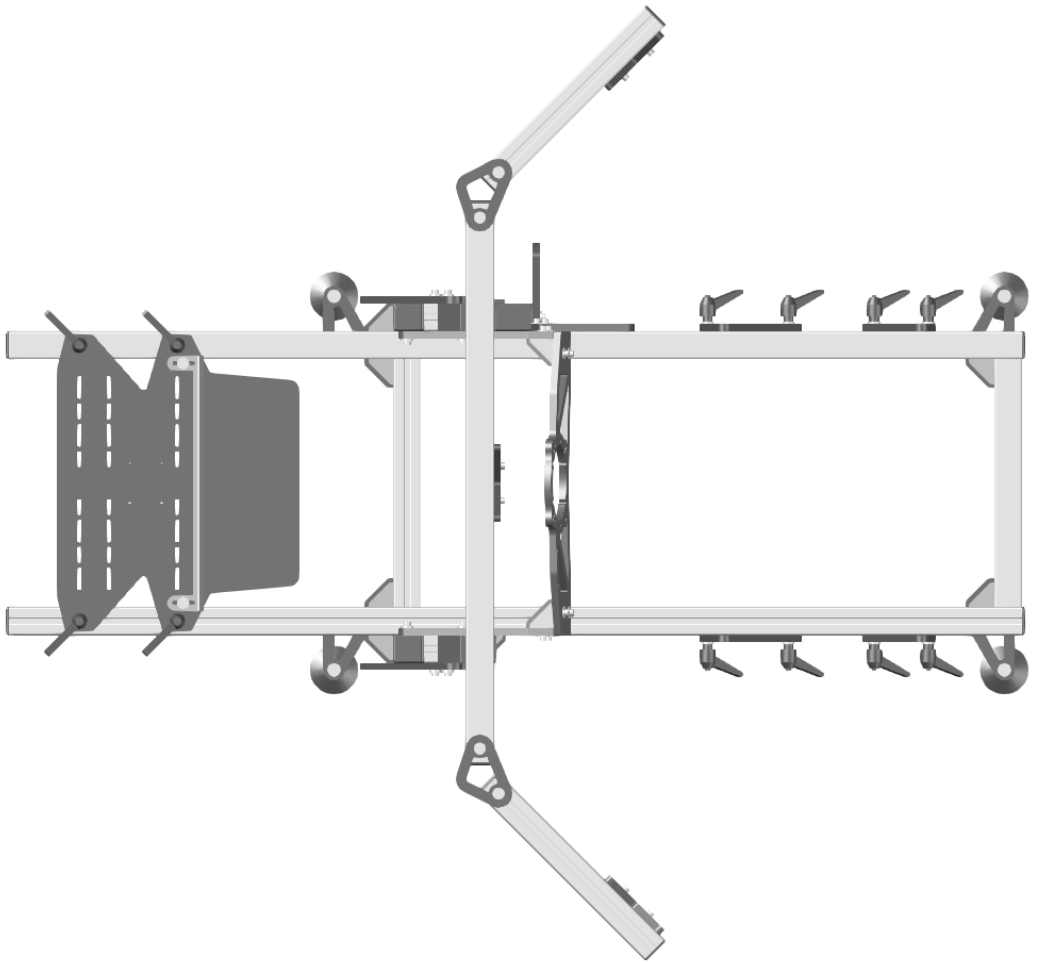

Side view

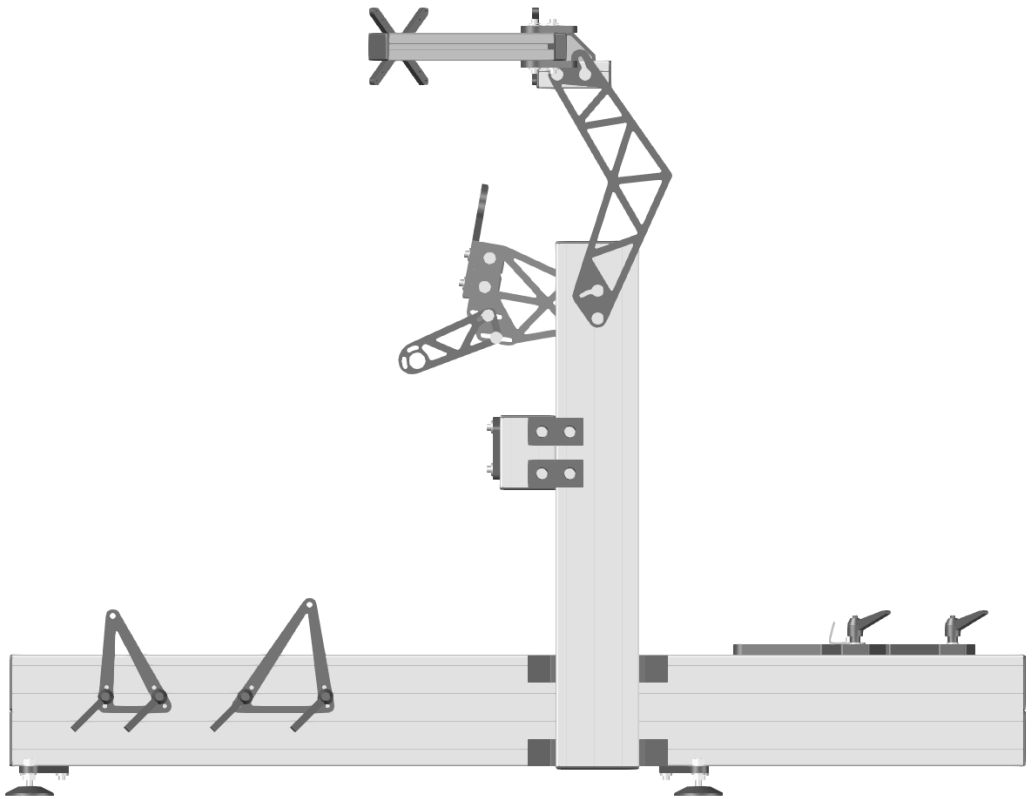

Ok, let's get to work! The actual assembly schematics start here. We recommend that you follow these instructions one by one.

Steering wheel & shifter mount assembly

Required parts and tools:

- 4x 90 degree corner brackets
(use screwdriver to break the lips off)
- 8x M6x25 bolts
- 16x M6x18x1.6 washer
- 8x M6 nut
- 4x corner bracket cover caps
- 2x side bracket (part 12)
- 1x main bracket (part 13)
- Shifter: 2x M6x30 bolts
- Shifter: 4x M6x18x1.6 washer
- Shifter: 2x M6 nut

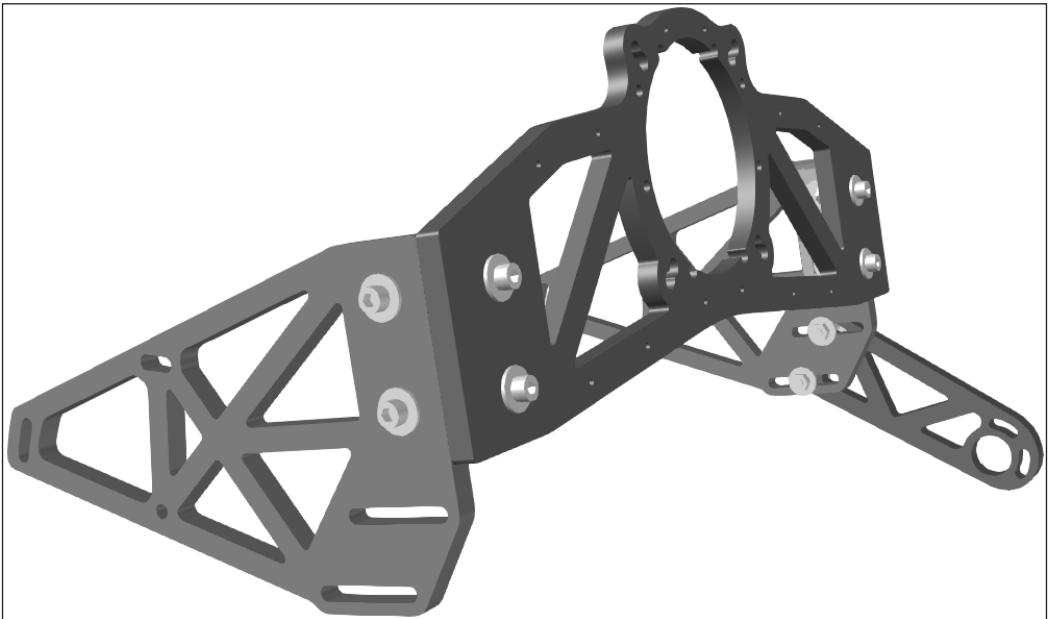
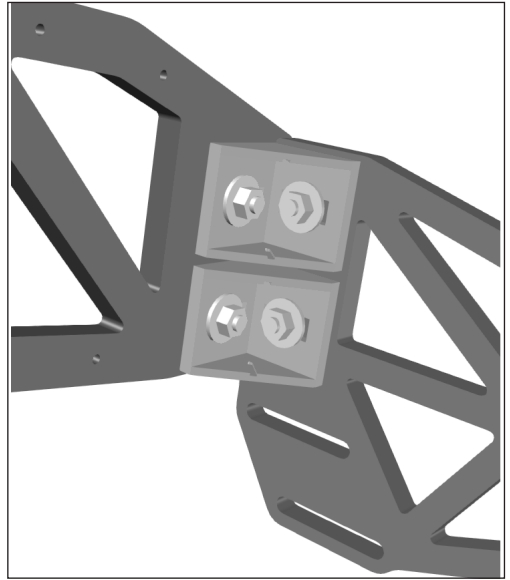

The top image on this page shows the appropriate mounting holes for your steering wheel.

- Cyan: OSW Mige 130 (M8x35 bolts + washers + M8 nuts)
- Red: SimSteering AKM5x, OSW Lenze (M8x35 bolts + washers + M8 nuts)
- Yellow: Accuforce Pro (M5x40 bolts and washers)
- Green: Fanatec CSW base (M6x30 bolts + spacers, also see the next image)

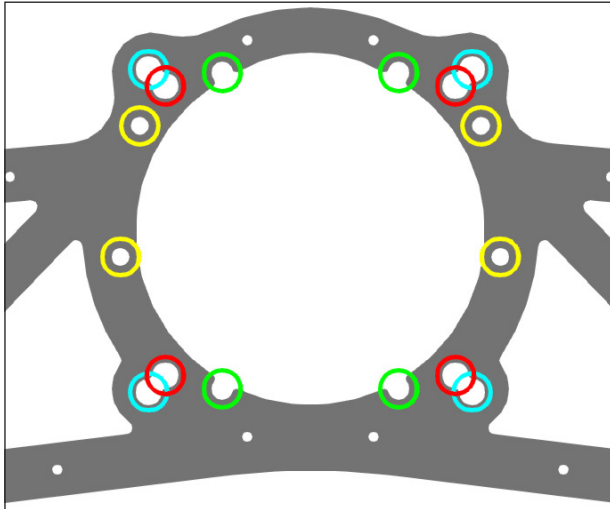

For mounting the Fanatec CSW you will also need to use the 2 provided powder coated spacers as you can see below.

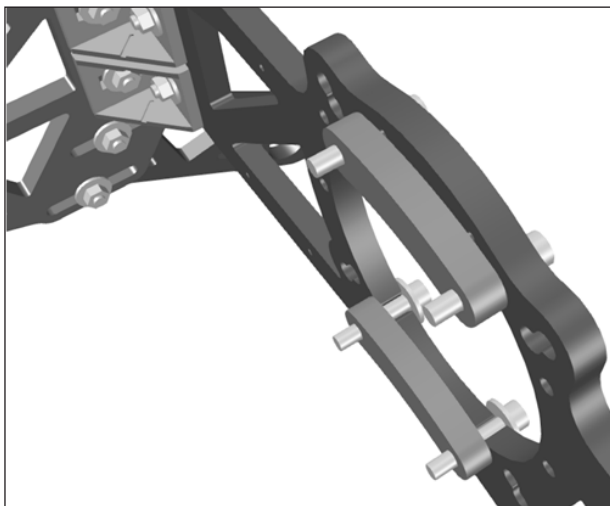

Handbrake mount assembly

This is only needed if you plan to mount the Heusinkveld Engineering Sim Handbrake. The assembly will mount to the vertical main frame beam later. The parts needed are:

- 80x40, 100mm length aluminium profile with 2 cover caps
- 2x M6 T nut
- 2x M6x25 bolt
- 4x large M6 washers, **2 per bolt!**
- 3x 80x40 countersunk holes steel connection plates
- 3x M8 countersunk bolts
- 3x M8 T nut
- 1x 10mm powder coated handbrake bracket (part 19)

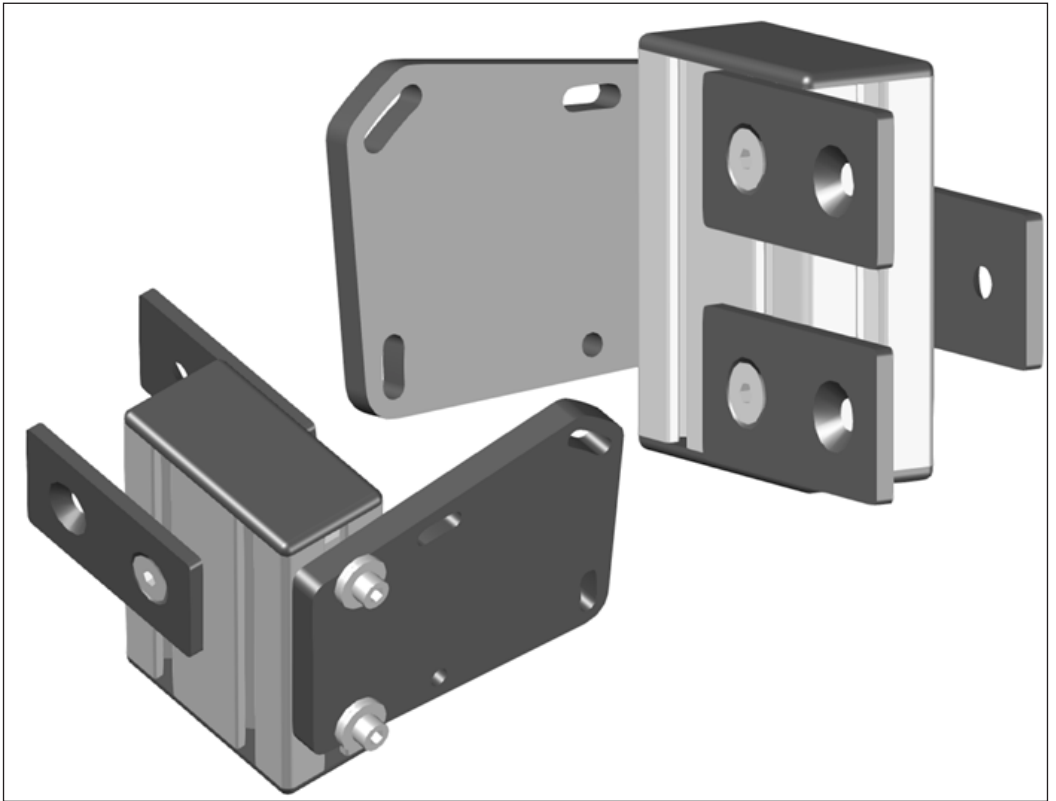

Monitor rack

One or three monitors can be mounted to the monitor rack. The angle of the side screens is completely adjustable and the entire rack can be placed closer or further from your eyes depending on your preference.

This guide assembles the frame for 3 monitors, you can leave certain parts out if you use only one screen. The following parts are required:

- 1x 40x40, 800mm length aluminium profile
- 2x 40x40, 360mm length aluminium profile
- 2x 40x40, 100mm length aluminium profile
- 10x 40x40 cover caps
- 2x 90 degree bracket with M8 T nut and M8 dome head bolt and cover cap
- 4x 10mm powder coated side monitor angle brackets (part 16)
- 2x 10mm powder coated vertical rack brackets (part 18)
- 3x 10mm powder coated VESA brackets (part 15)
- 24 large M6 washers, **2 per bolt!**
- 12x M6x25mm bolts
- 6x M6x20mm bolts
- 18x M6 T nut

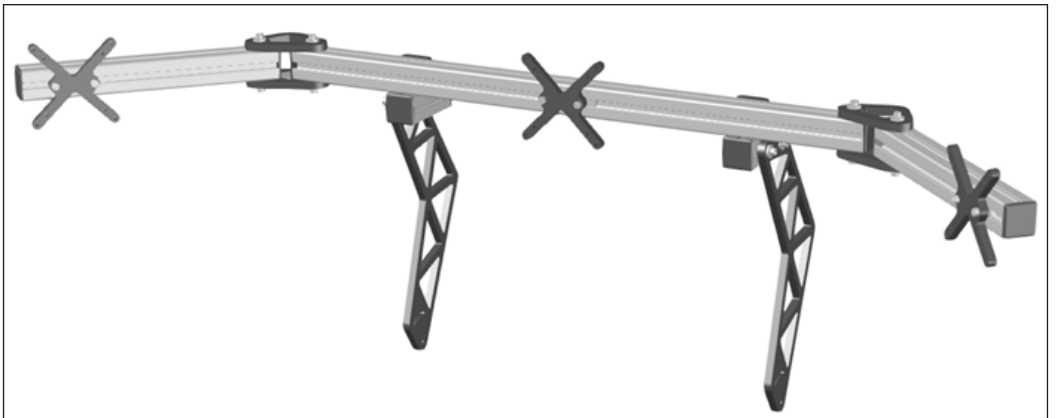

Make sure there is 435mm (+-1mm) between the two short pieces of profile. Also make sure the long aluminium profile is nicely centered. There is $(800-435-80)/2 = 142.5\text{mm}$ from each end to the short profiles.

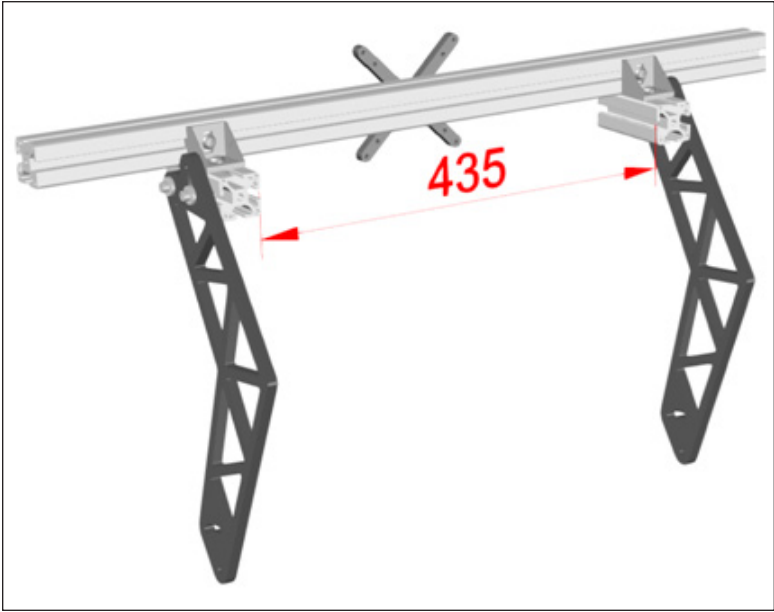

Mount the VESA brackets without washers using M6x20 bolts. Mount the side brackets with 2 washers and M6x25 bolts.

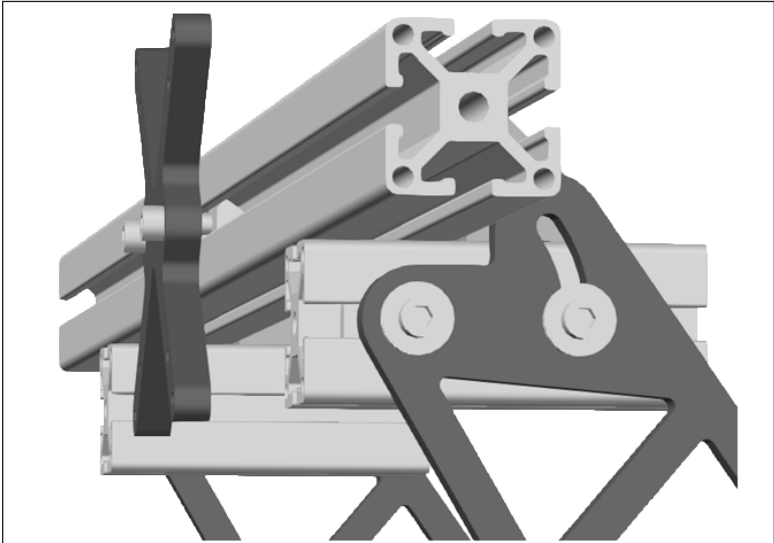

The side screen adjustment brackets go in with M6x25mm bolts, using 2 washers.

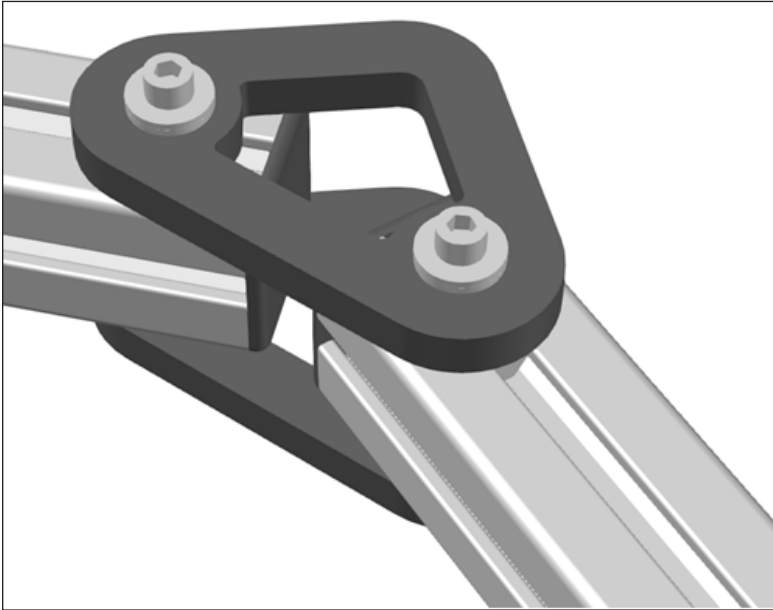

Small screens can use the method on the left image to bring the side screens closer. The picture on the right is suitable for 27" and 28" screens.



Simulator Feet

While wheels might be more realistic, we prefer to have the simulator staying in one place.

To assemble the feet you need:

- 4x black plastic feet
- 8x M10 washer
- 8x M10 nut
- 4x powder coated feet (part 14)

Don't forget to use M6x25 bolts with 2 washers when mounting the feet to the frame. Beware that the feet are not symmetrically shaped. Assemble two 'left' and two 'right' feet.

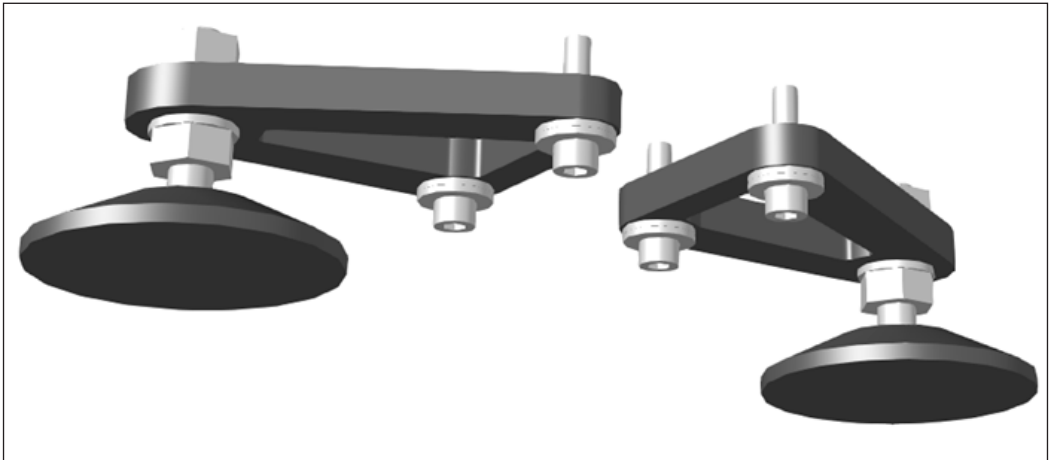

Main frame

The simple design uses 160x40mm profiles for the main ladder frame. This results in extreme stiffness and almost no bending flex even at extreme brake pedal forces. 120x40mm vertical beams are strong and stiff enough to keep the monitor rack and steering wheel firmly in place. For this step you need:

- 16x 90 degree corner brackets with M8 T nut, M8 dome head bolt and cover cap
- 2x 40x160mm aluminium profile 1495mm length
- 2x 40x160mm aluminium profile 355mm length
- 2x 40x120mm aluminium profile 750mm length
- 8x cover cap 40x80mm for 40x160 profiles
- 4x cover cap 40x120mm for vertical profiles

Take care during assembly that the distance between the vertical beams and the front of the frame (550mm) is the same on both sides and that the vertical beams are indeed vertical. There is a possibility to attach them at an ever so slight angle. Doing this on a flat surface such as a table makes this the easiest.

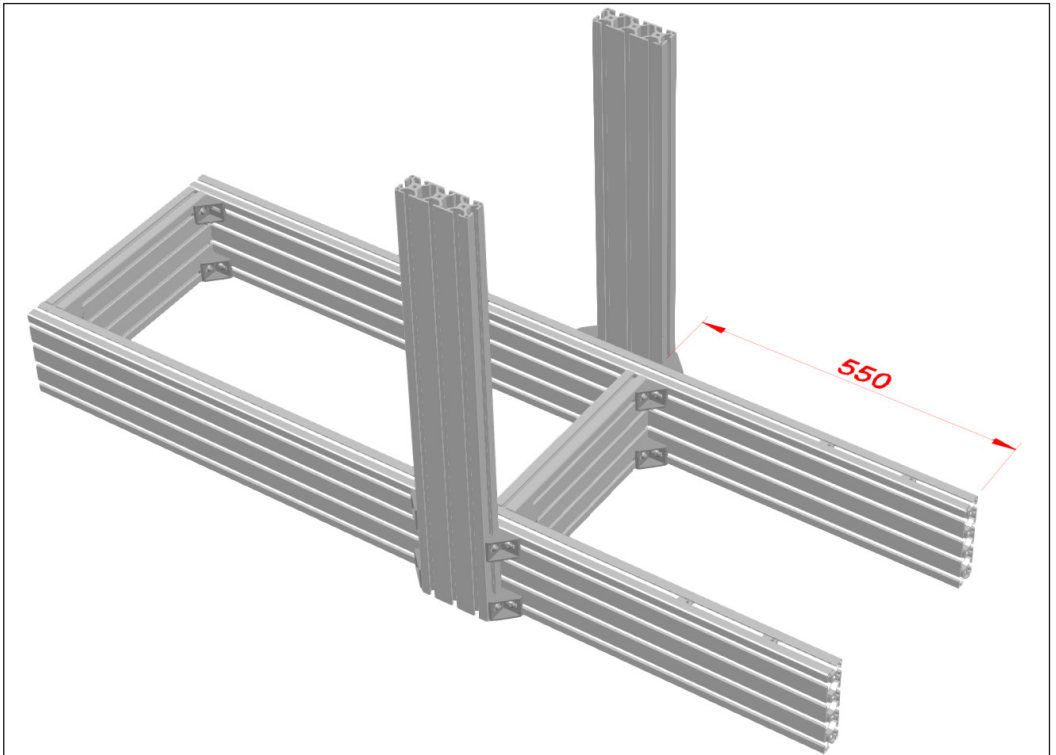

Mounting the feet to the frame

The feet have to be mounted as shown below. Mounting the front feet too far forward will cause bending in the aluminium profiles. The front feet are only just in front of the vertical profiles. Parts required are:

- 8x M6x25 bolt
- 16x large M6 washer, **2 per bolt!**
- 8x M6 T nut

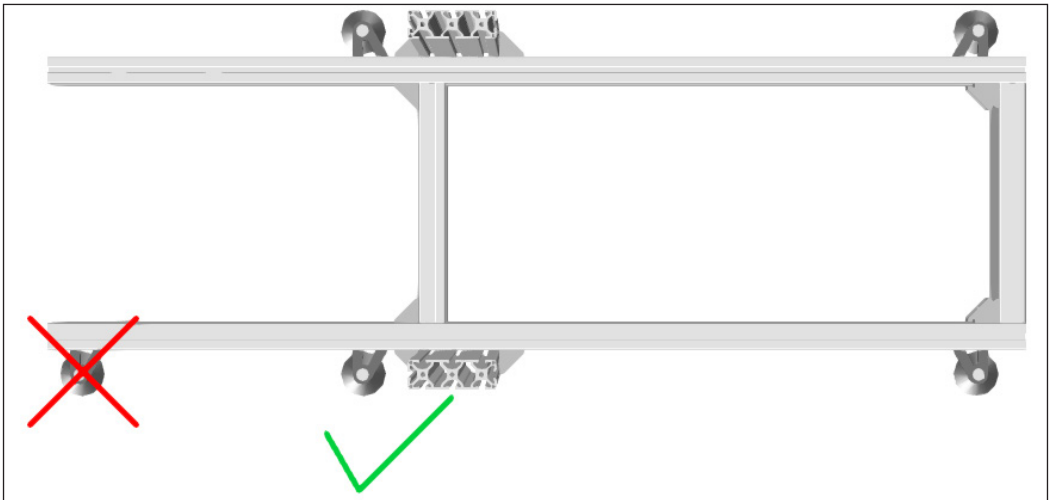

Mounting the seat brackets to the frame

By separating the 'front' and 'rear' brackets, almost all side mounting seats should be able to fit on the frame. The brackets have fine tuning holes for adjusting the height. By going up or down one slot in the aluminium profile you can further change how low or high you want to sit. Did we mention it is adjustable? Parts required are:

- 8x M8 locking lever (without integrated bolt)
- 8x M8 bolt
- 8x bolt lock plate
- 24x large M8 washers (3 per bolt)
- 2x front seat bracket (part 9)
- 2x rear seat bracket (part 8)

First slide the bolt lock plates into the outside of the main horizontal beam of the frame.

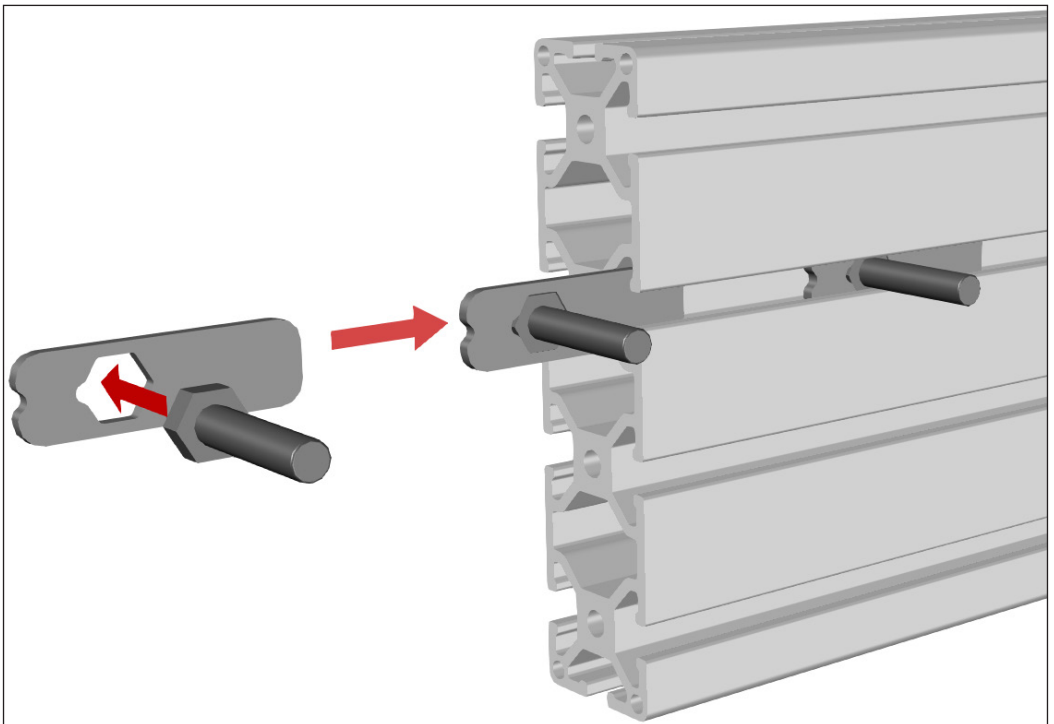

Then mount the bracket parts onto the bolts, using 3 washers per bolt and a locking lever.

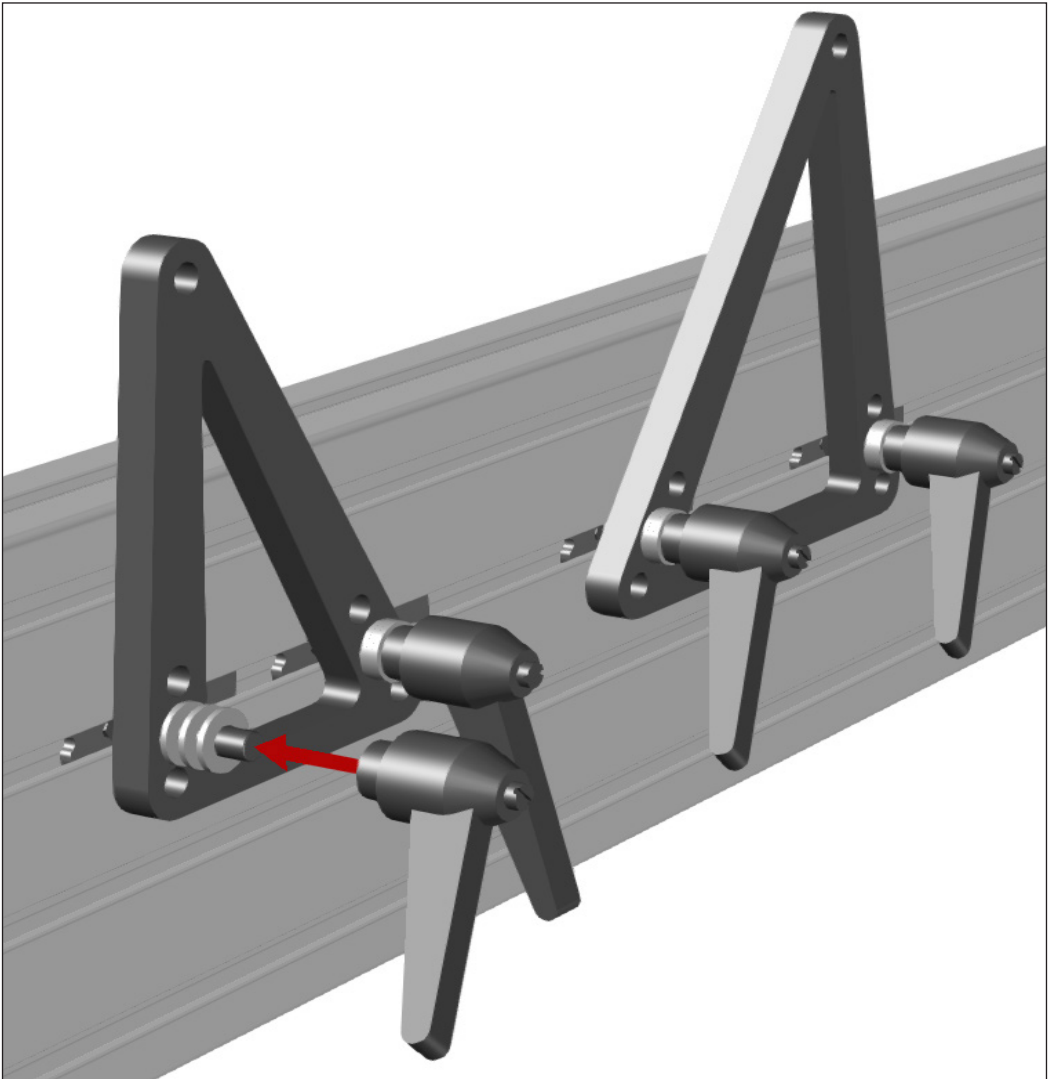

Mounting the pedal plate to the frame

An extremely strong 15mm solid aluminium plate makes sure the pedal plate won't flex even at high pedal forces. Mounting it is simple. You need:

- 4x M6x30 grip handles (with integrated bolt)
- 10x large M6 washers, **2 per locking lever!**
- 4x M6 T nuts
- 1x pedal plate (part 10)
- 1x heel bracket (part 20)
- 2x M6x20 bolt for heel bracket mounting

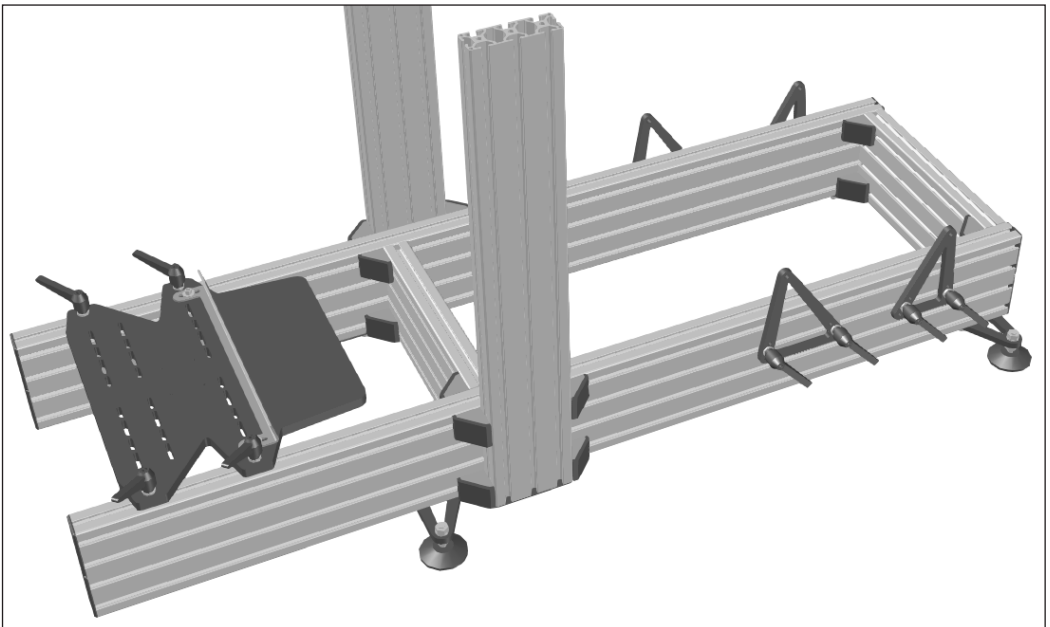
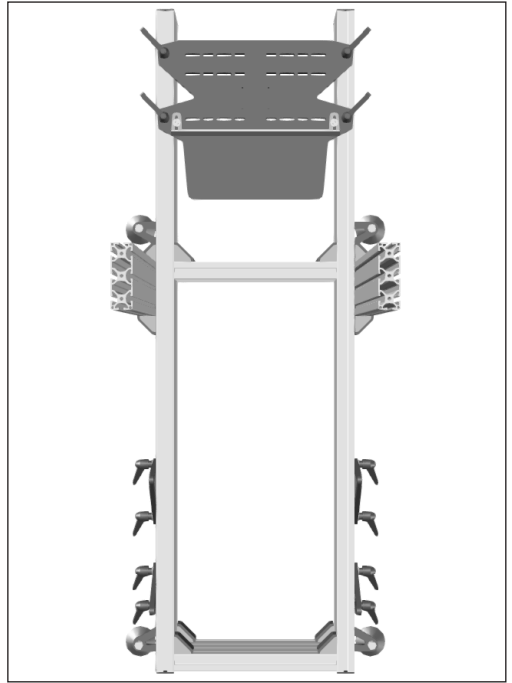

Mounting the wheel bracket assembly to the frame

To mount the already assembled steering wheel bracket to the frame you need:

- 6x M6x25 bolt
- 12x large M6 washer, **2 per bolt!**
- 6x M6 T nut
- Steering wheel bracket assembly

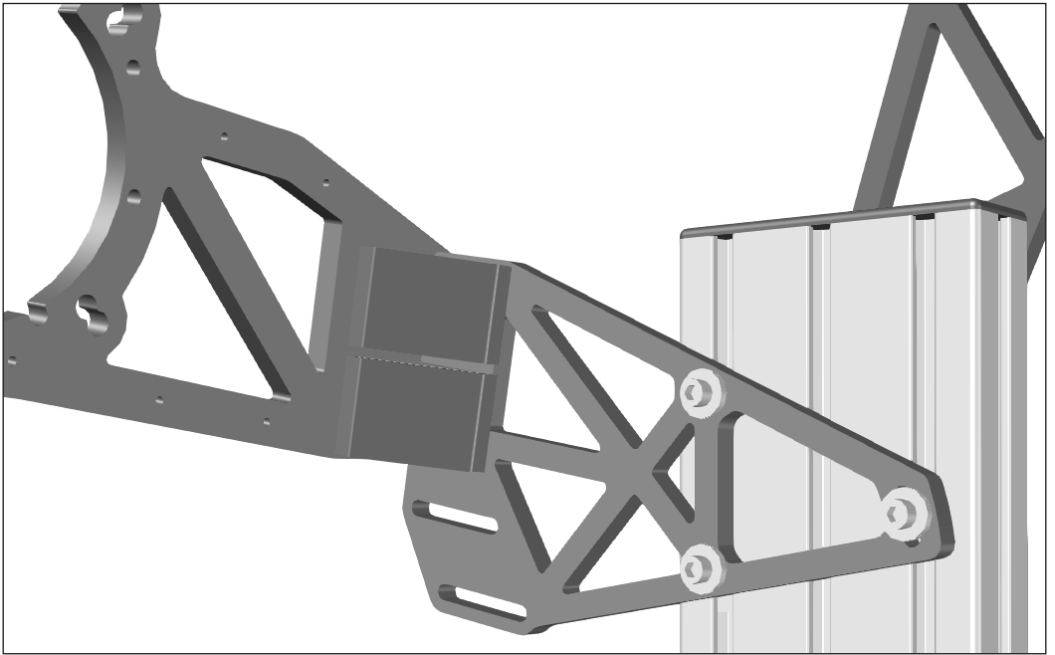

The lower left bolt goes through a hole, the other two are slots, allowing you to adjust the angle at which the steering wheel sits.

Mounting the monitor rack to the frame

The monitor rack assembly can now be mounted using the following parts:

- 4x M6x25 bolt
- 8x large M6 washer (2 per bolt!)
- 4x M6 T nut
- Monitor rack assembly

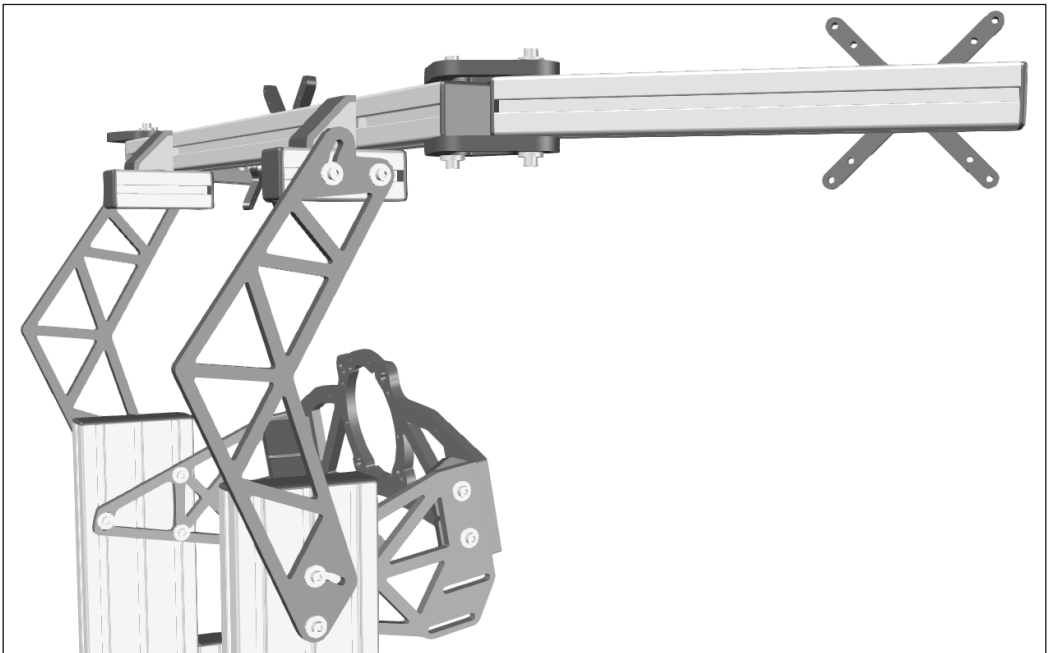

Mounting the handbrake assembly to the frame

The handbrake mounting assembly we made earlier now attaches to the vertical main beam of the frame using:

- 3x M8 T nut
- 3x M8 countersunk screw

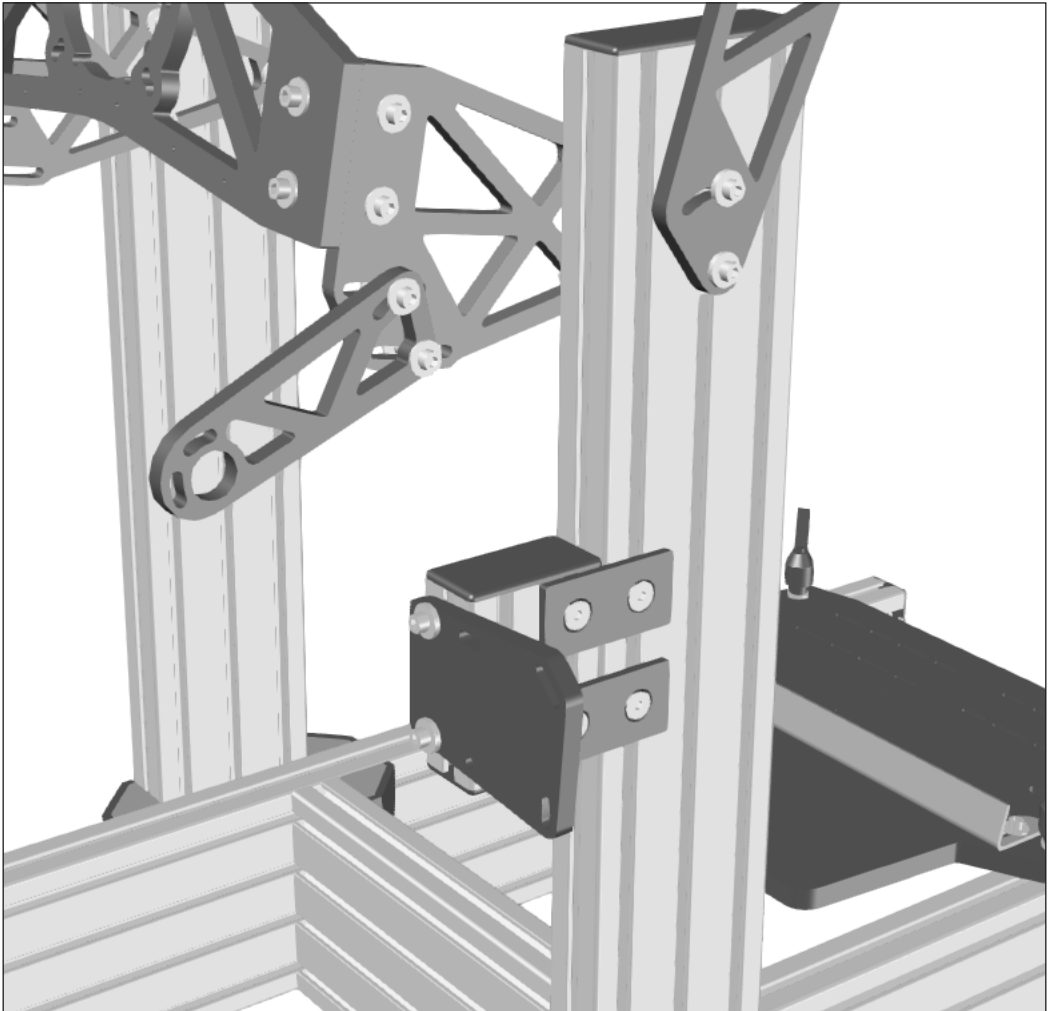

Finishing your simulator

If you have followed all the instructions in this manual one by one your Sim Rig GT frame will now be ready. In order to build a working simulator, you of course need to add other peripherals.

HE Sim Pedals

Mounting the Sim Pedals Pro or Ultimate to the pedal plate is similar to mounting them to our standalone Sim Pedals Baseplate product. We'd like to refer you to our online manual for the Sim Pedals Baseplate (<http://www.h-engineering.net/support/>) for installation instructions.

There are enough mounting materials supplied with your Sim Rig GT product which can be used for mounting the pedals and the controller (thickness of bolts must be identical, the length of the bolts may vary a bit compared to the Sim Pedals Baseplate manual).

HE Sim Shifter Sequential

The steering wheel assembly of the Sim Rig GT has a mount for the Sim Shifter Sequential. The shifter should be mounted on the 'outside' of the mount. In order to install the shifter, please do the following:

- Remove 2 bolts on one the side of the shifter. You can discard these original bolts.
- Place the shifter against the mount. The black plastic cover should fit in the large circular hole in the powder coated bracket. The USB cable socket should face towards the pedals.
- Insert two 25mm or 30mm bolts through the bracket and then into the shifter. Use a washer between the bolt head and the bracket. Tighten these bolts.

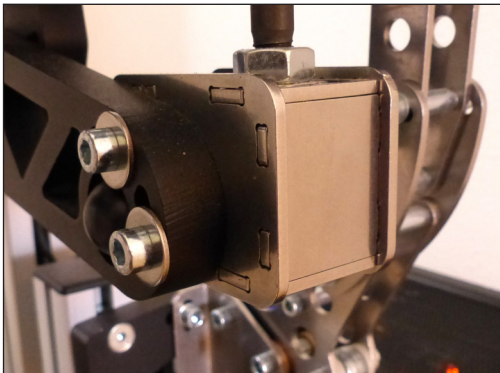

Sim Shifter Sequential mount

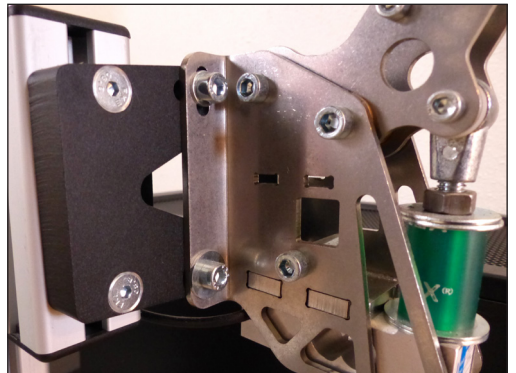

Sim Handbrake mount

HE Sim Handbrake

To the right of the steering wheel and shifter assembly is the mount for the Sim Handbrake. You can mount the Sim Handbrake (with the main unit of the handbrake in a vertical position) using M6x25 bolts, M6 nuts and M6 washers (these are supplied with the Sim Rig GT). On the previous page you can see an image of an installed Sim Handbrake.

Wheel

For installation of the wheel motor we refer to the 'Steering Wheel Assembly' paragraph earlier in this manual. These instructions contain a schematic on how to mount your wheel motor.

Seat & Monitors

For mounting the seat and monitors to the frame, we refer to the earlier paragraphs 'Seat' and 'Monitor' in this manual, as well as to the instructions supplied by the respective manufacturer.

PC, wheel controller box and cables

You are free to position your pc and (if applicable) wheel controller box in any position you want. Personally we choose the following setup:

- Wheel controller box positioned to the right of the pedal plate.
- PC positioned to the right of the main vertical beams of the chassis.
- We mount a central 8 way electrical socket below the pedal plate onto the aluminium frame (out of view)
- All electrical plugs (including the power supply for the monitors) are routed to this central socket.
- We use cable binding blocks together with cable ties (both are supplied with your Sim Rig GT) to neatly route the cables.

We hope you thoroughly enjoy your Sim Rig GT. Due to the flexibility this product offers with regard to peripherals, seats, different set-up options etcetera you may encounter situations which are not explained or illustrated in this manual.

If you have any questions or suggestions, please send us an email at:

info@h-engineering.net

The latest version of this manual can also be viewed at:

<http://www.h-engineering.net/support>



GTB
CONTINENTAL

WOLFGANG REIP

Blancpain GT Champion and Bentley factory driver

“Simulator training is essential for my race preparation. Products from Heusinkveld Engineering are the best and most realistic I have ever tried on my simulator.”