

K - Obstacles Agility - Haies (Dessins)

Haie simple

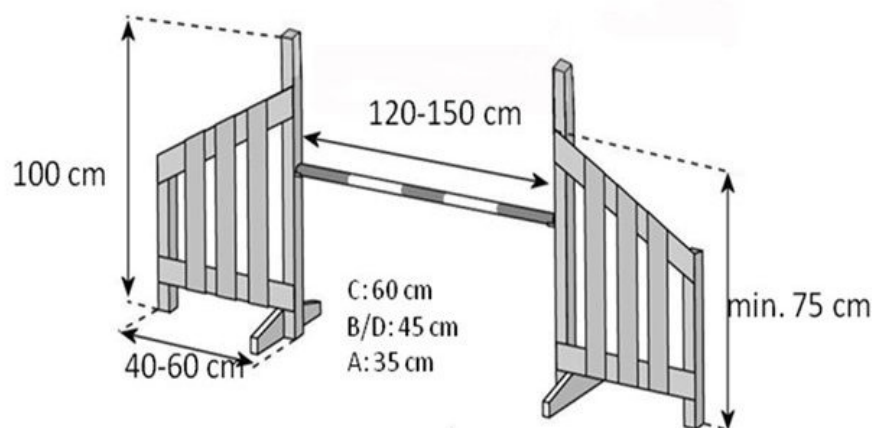

Panneau Plein

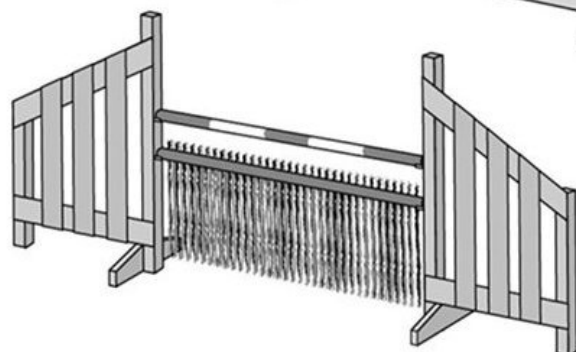
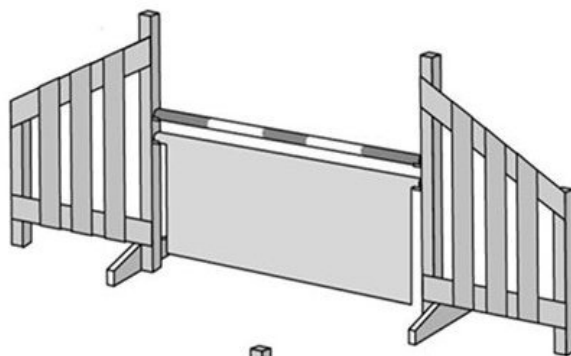

Panneau Paille

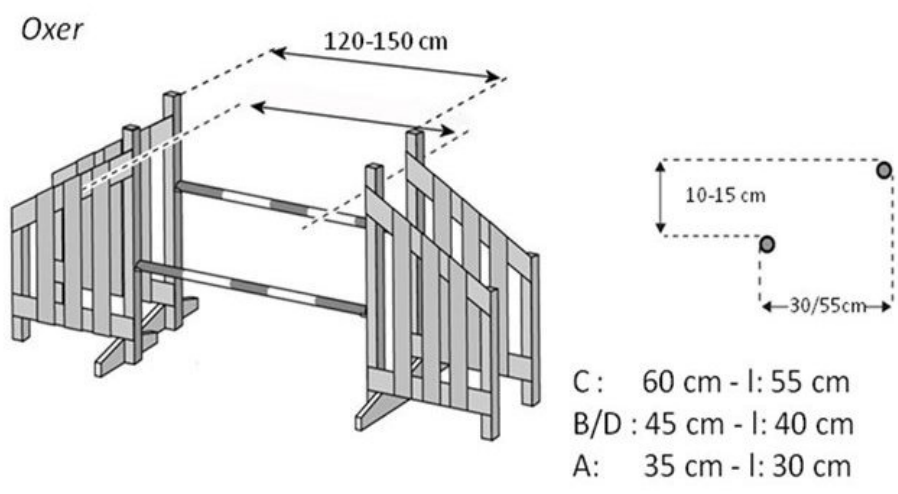

Château/Viaduc

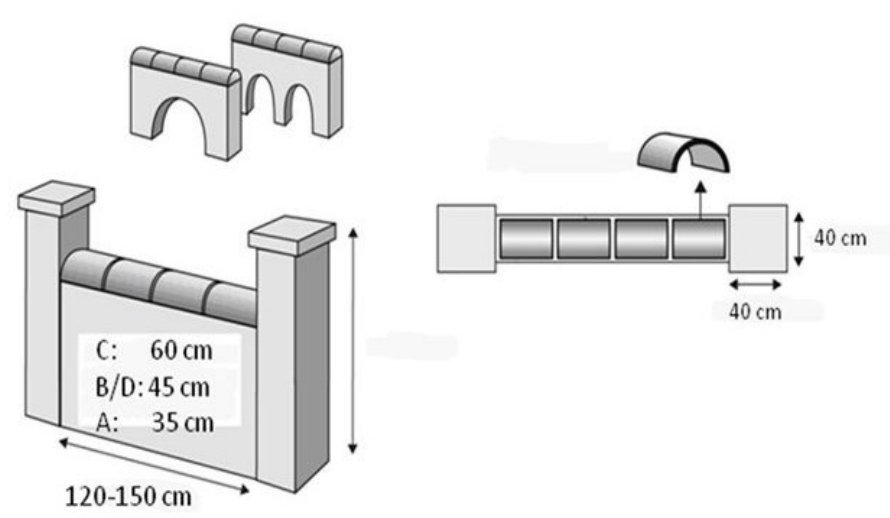

Saut en longueur

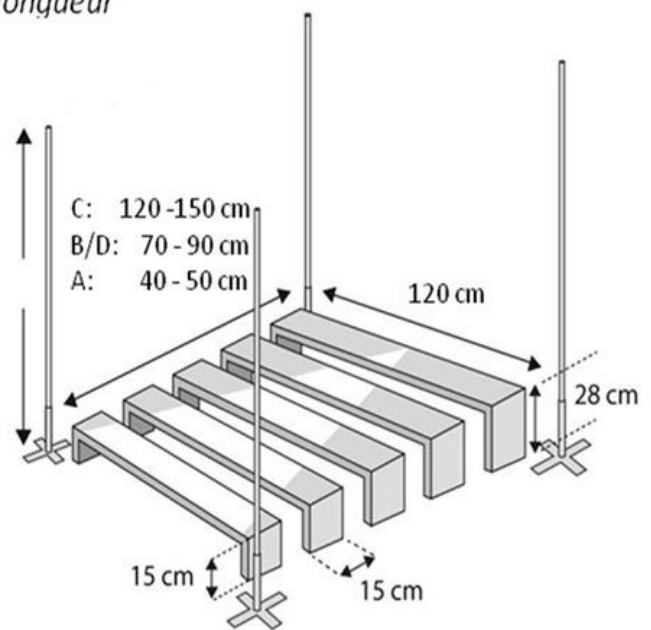

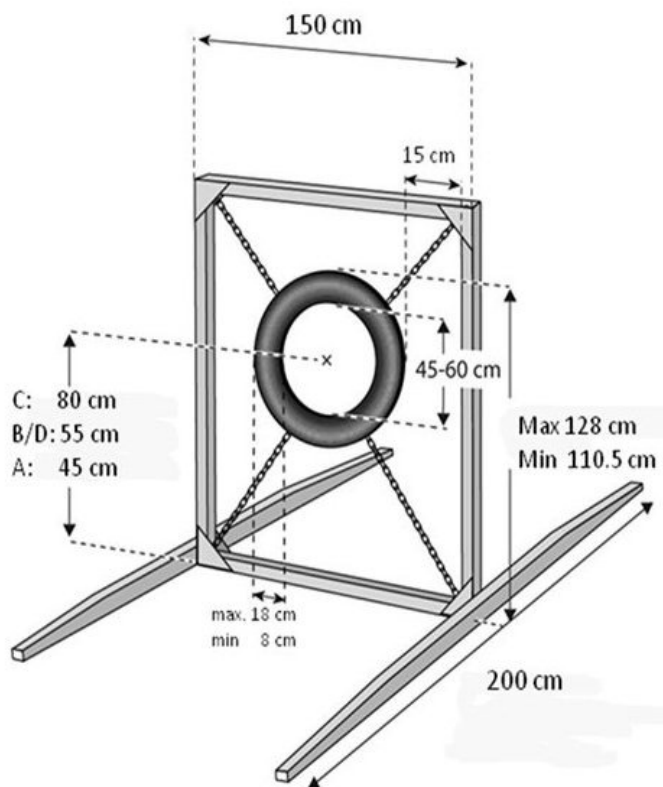
Pneu[< J - Obstacles Agility - Zones de contact \(Dessins\)](#)

haut

[L - Obstacles Agility - Autres obstacles \(Dessins\) >](#)

chargement